

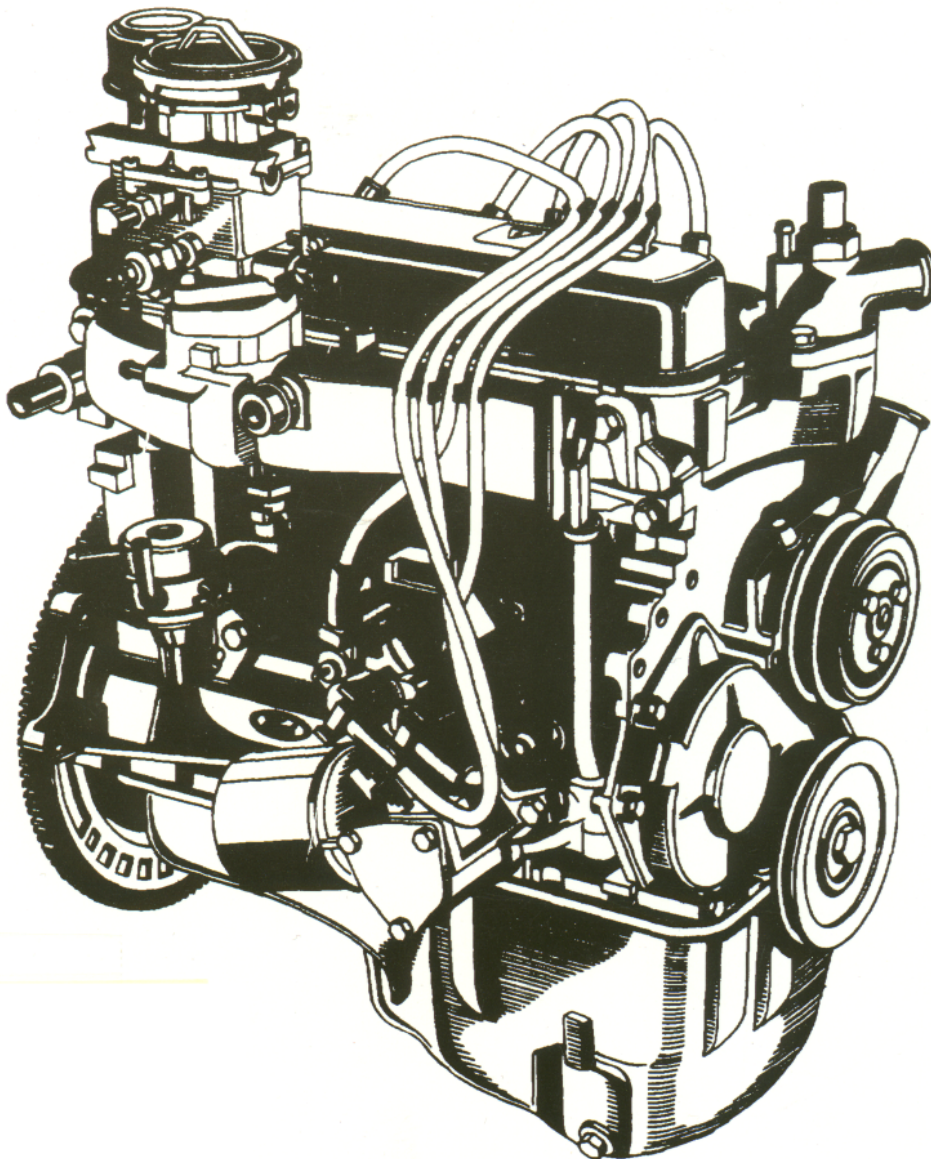

VSG-411/413 ENGINE SERVICE MANUAL

The Source for Power...
Worldwide™

For Engines Produced 1993 and Later



IMPORTANT SAFETY NOTICE

Appropriate service methods and proper repair procedures are essential for the safe, reliable operation of all motor vehicles as well as the personal safety of the individual doing the work. This Shop Manual provides general directions for accomplishing service and repair work with tested, effective techniques. Following them will help assure reliability.

There are numerous variations in procedures, techniques, tools, and parts for servicing vehicles, as well as in the skill of the individual doing the work. This Manual cannot possibly anticipate all such variations and provide advice or cautions as to each. Accordingly, anyone who departs from the instructions provided in this Manual must first establish that he compromises neither his personal safety nor the vehicle integrity by his choice of methods, tools or parts.

NOTES, CAUTIONS, AND WARNINGS

As you read through the procedures, you will come across NOTES, CAUTIONS, and WARNINGS. Each one is there for a specific purpose. NOTES give you added information that will help you to complete a particular procedure. CAUTIONS are given to prevent you from making an error that could damage the vehicle. WARNINGS remind you to be especially careful in those areas where carelessness can cause personal injury. The following list contains some general WARNINGS that you should follow when you work on a vehicle.

- Always wear safety glasses for eye protection.
- Use safety stands whenever a procedure requires you to be under the vehicle.
- Be sure that the ignition switch is always in the OFF position, unless otherwise required by the procedure.
- Set the parking brake when working on the vehicle. If you have an automatic transmission, set it in PARK unless instructed otherwise for a specific operation. If you have a manual transmission, it should be in REVERSE (engine OFF) or NEUTRAL (engine ON) unless instructed otherwise for a specific operation. Place wood blocks (4" x 4" or larger) to the front and rear surfaces of the tires to provide further restraint from inadvertent vehicle movement.
- Operate the engine only in a well-ventilated area to avoid the danger of carbon monoxide.
- Keep yourself and your clothing away from moving parts when the engine is running, especially the fan and belts.
- To prevent serious burns, avoid contact with hot metal parts such as the radiator, exhaust manifold, tail pipe, catalytic converter and muffler.
- Do not smoke while working on the vehicle.
- To avoid injury, always remove rings, watches, loose hanging jewelry, and loose clothing before beginning to work on a vehicle. Tie long hair securely behind the head.
- Keep hands and other objects clear of the radiator fan blades. Electric cooling fans can start to operate at any time by an increase in underhood temperatures, even though the ignition is in the OFF position. Therefore, care should be taken to ensure that the electric cooling fan is completely disconnected when working under the hood.

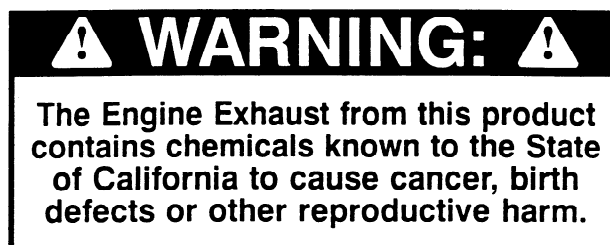

Introduction

In general, this manual covers the servicing of the engine and associated standard equipment. In many cases, engines are supplied with accessories and equipment that are unique to the application. If service information is ever required on such unique accessories or equipment it is suggested that Power Products Division/GRI be contacted. The proper information will either be forwarded or the Service Technician will be advised where it can be obtained.

The information in this manual is grouped in sections according to the type of work being performed. The various sections are indicated in the index. In addition, each section is subdivided to include topics such as diagnosis and testing, cleaning and inspection, overhaul, removal and installation procedures, disassembly and assembly procedures, and service specifications.



The Source for Power...
Worldwide™

POWER PRODUCTS DIVISION/GRI
28333 TELEGRAPH ROAD - #300
SOUTHFIELD, MICHIGAN 48034

The descriptions and specifications contained in this manual were in effect at the time the book was released for printing. Power Products Division/GRI reserves the right to discontinue models at any time, or change specifications or design, without notice and without incurring obligation.

NOTE: *The recommendations and suggestions contained in this*

SECTION TITLE	PAGE	SECTION TITLE	PAGE
BASIC ENGINE	01-1	STARTING SYSTEM	05-1
IGNITION SYSTEM – DISTRIBUTORLESS	02-1	GOVERNOR	06-1
FUEL SYSTEM	03-1	COOLING SYSTEM	07-1
EMISSION CONTROL SYSTEM	03A-1	SPECIFICATIONS	08-1
CHARGING SYSTEM	04-1		

SECTION 01 — Basic Engine

SUBJECT	PAGE	SUBJECT	PAGE
IDENTIFICATION	01-3	Cylinder Heads	01-12
DESCRIPTION	01-4	Tappets	01-14
DIAGNOSIS AND TESTING	01-6	Timing Chain and Sprockets	01-14
Camshaft Lobe Lift	01-6	Camshaft	01-14
Compression Test	01-6	Camshaft Bores	01-14
Compression Gauge Check	01-6	Crankshaft	01-14
Test Conclusion	01-6	Flywheel	01-15
Crankshaft End Play	01-7	Connecting Rods	01-15
Flywheel Face Runout	01-7	Pistons, Pins and Rings	01-16
Camshaft End Play	01-7	Main and Connecting Rod Bearings	01-16
OVERHAUL	01-8	Cylinder Block	01-16
Cylinder Head	01-8	Oil Pan	01-17
Reaming Valve Guides	01-8	Oil Pump	01-17
Refacing Valve Seats	01-8	REMOVAL AND INSTALLATION	01-19
Valves	01-8	Valve Rocker Arm Cover, Rocker Arm and/or Shaft	01-19
Refacing Valves	01-8	Intake Manifold	01-19
Select Fitting Valves	01-9	Exhaust Manifold	01-19
Camshaft Repair	01-9	Cylinder Head	01-20
Crankshaft	01-9	Valve Spring, Retainer and Stem Seal	01-21
Refinishing Journals	01-9	Cylinder Head Removed	01-21
Fitting Main or Connecting Rod Bearings		Cylinder Head Installed	01-21
With Plastigage	01-9	Water Pump	01-22
Pistons, Pins and Rings	01-10	Cylinder Front Cover and Timing Chain, or	
Fitting Pistons	01-10	Crankshaft Sprockets	01-22
Fitting Piston Rings	01-10	Adjusting Valve Clearances	01-23
Fitting Piston Pins	01-11	Crankshaft Front Oil Seal	01-24
Valve Rocker Arm and/or Shaft Assembly	01-11	Camshaft and/or Valve Lifters	01-24
Push Rods	01-11	Camshaft Bearings	01-25
Cylinder Block	01-11	Oil Pump	01-26
Refinishing Cylinder Walls	01-11	Oil Pan	01-26
Repairing Sand Holes or Porous Engine		Flywheel Ring Gear	01-26
Castings	01-11	Crankshaft Rear Oil Seal	01-27
CLEANING AND INSPECTION	01-12	Pistons and Connecting Rods	01-27
Intake Manifold	01-12	Oil Filter	01-28
Exhaust Manifolds	01-12	DISASSEMBLY AND ASSEMBLY	01-29
Valve Rocker Arm and/or Shaft Assembly	01-12	Engine Assembly	01-29
Push Rods	01-12	Oil Pump	01-32

BLANK

IDENTIFICATION

An Identification Decal is affixed to the left side of the rocker cover of each engine. The decal contains the engine serial number which identifies this unit from all others. Next is the engine displacement which determines the engine specifications, then the model number and S.O. or special options which determine the parts or components required on this unit. Use all numbers when seeking information or ordering replacement parts for this engine.

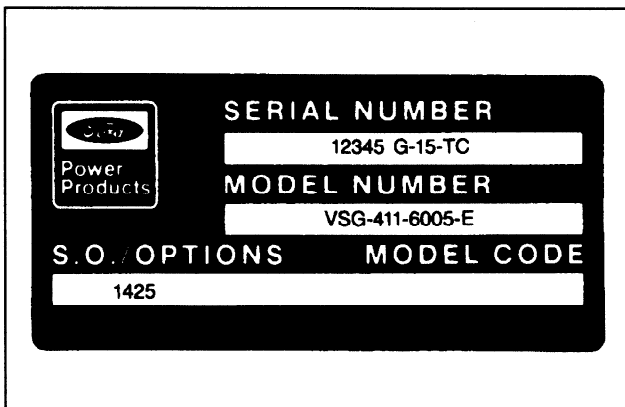

Identification of the cylinder block and therefore of the basic engine type can be made by reference to the stampings on the left rear top edge of the cylinder block.

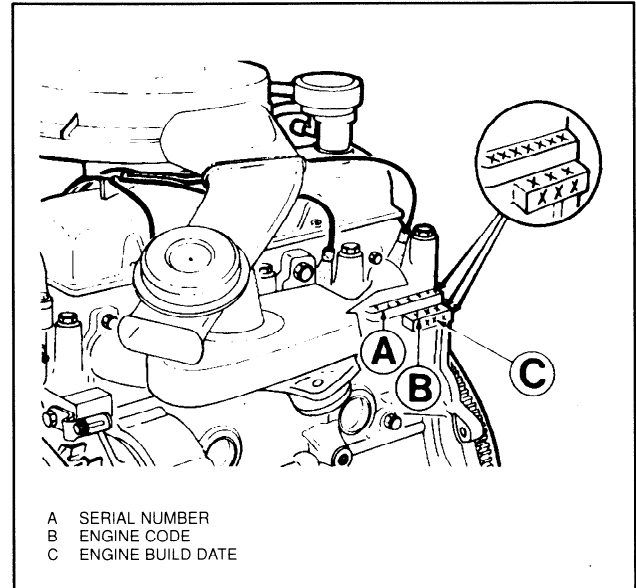

The engine code will begin with a "G" This will indicate that it is a 1.1 liter engine.

The engine build date follows the corporate system. Example: "4K26". The first number indicates the year. The letter indicates the month in alphabetical sequence, A January, B February, etc. omitting I. The last two numbers are the day of the month.

DESCRIPTION

The engine is a water-cooled, 4 cylinder, 4 stroke, in-line gasoline engine. The cylinder head in which the combustion chambers are located is of a cross-flow type, the fresh fuel/air mixture is drawn in on one side and burnt gases are passed into the exhaust system on the opposite side.

The valves are suspended in the cylinder head and are operated by means of tappets, pushrods and rocker arms.

The valves are disposed in an alternating pattern in the cylinder head starting with an exhaust valve by the thermostat housing.

The three-bearing camshaft is located on the right side of the cylinder block and driven by roller chain from the crankshaft.

The common driving gear shared by the distributor and oil pump is located behind the second cam on the camshaft, the eccentric cam driving the fuel pump is located between the sixth and seventh cams.

The oil pump is bolted onto the outside of the cylinder block below the distributor. The full-flow oil filter is angled downwards and mounted directly on the oil pump.

The crankshaft is mounted in five bearings. The crankshaft end play is determined by thrust half rings at the center main bearing.

The front crankshaft journal is sealed by means of an oil seal installed in the timing cover.

The rear crankshaft journal is sealed by means of an oil seal pressed into an oil seal carrier.

The timing cover has cast ignition timing degree marks or a TDC reference pointer. A notch on the crankshaft belt pulley is used in conjunction with either the degree or TDC reference points when installing the distributor and checking timing. They are visible on the front, left side of the engine.

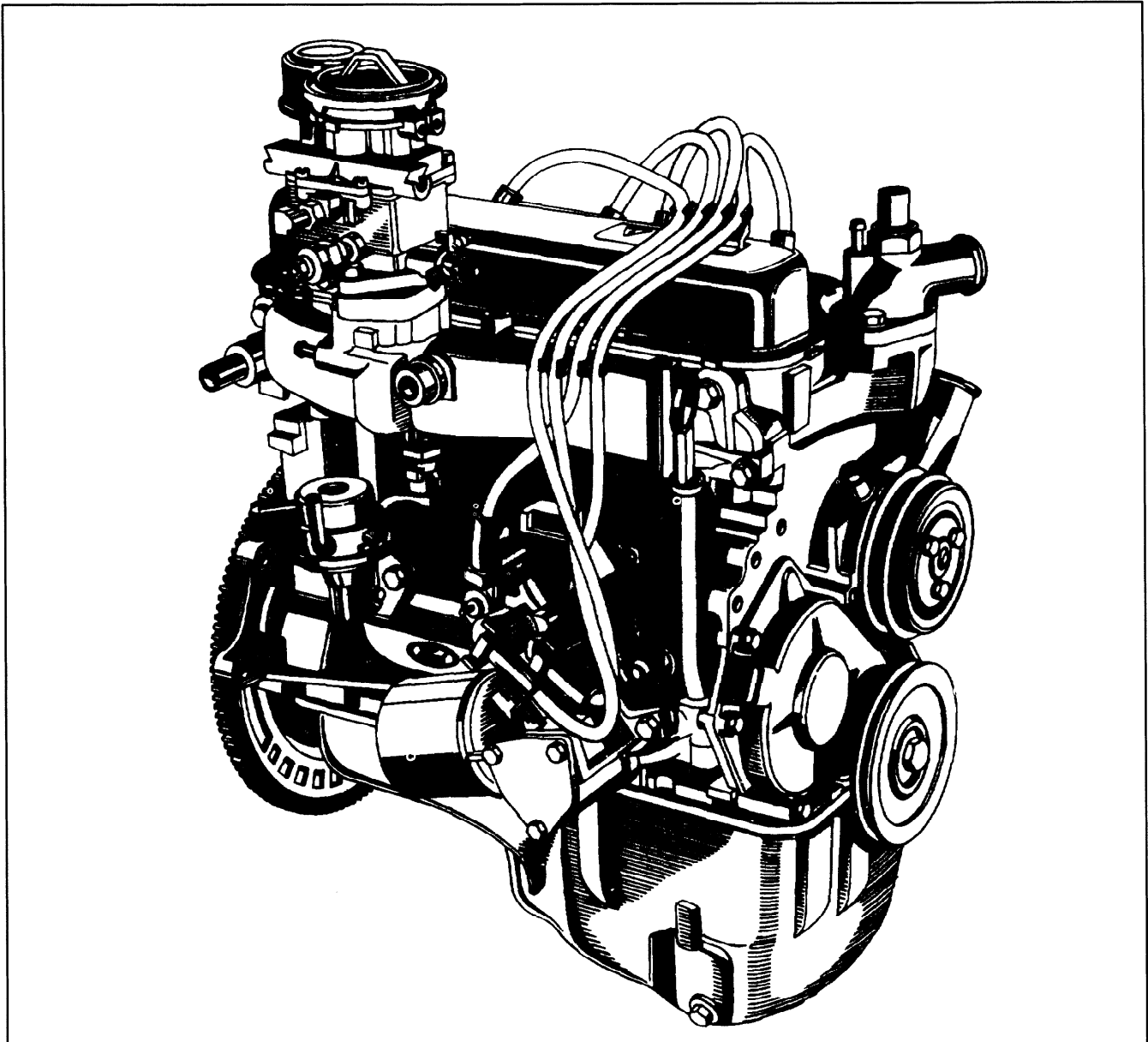

DESCRIPTION (Continued)

The spark plugs have a tapered seat without a sealing ring.

Engine Ventilation:

The ventilation system consists of an oil filler cap with two connecting hoses, one of which passes to the inlet manifold and the other to the air cleaner.

The result is a closed ventilation system in which the fumes from the crankcase pass back via the inlet manifold into the cylinders for combustion.

Gas flow is regulated by a calibrated orifice in the oil filler cap.

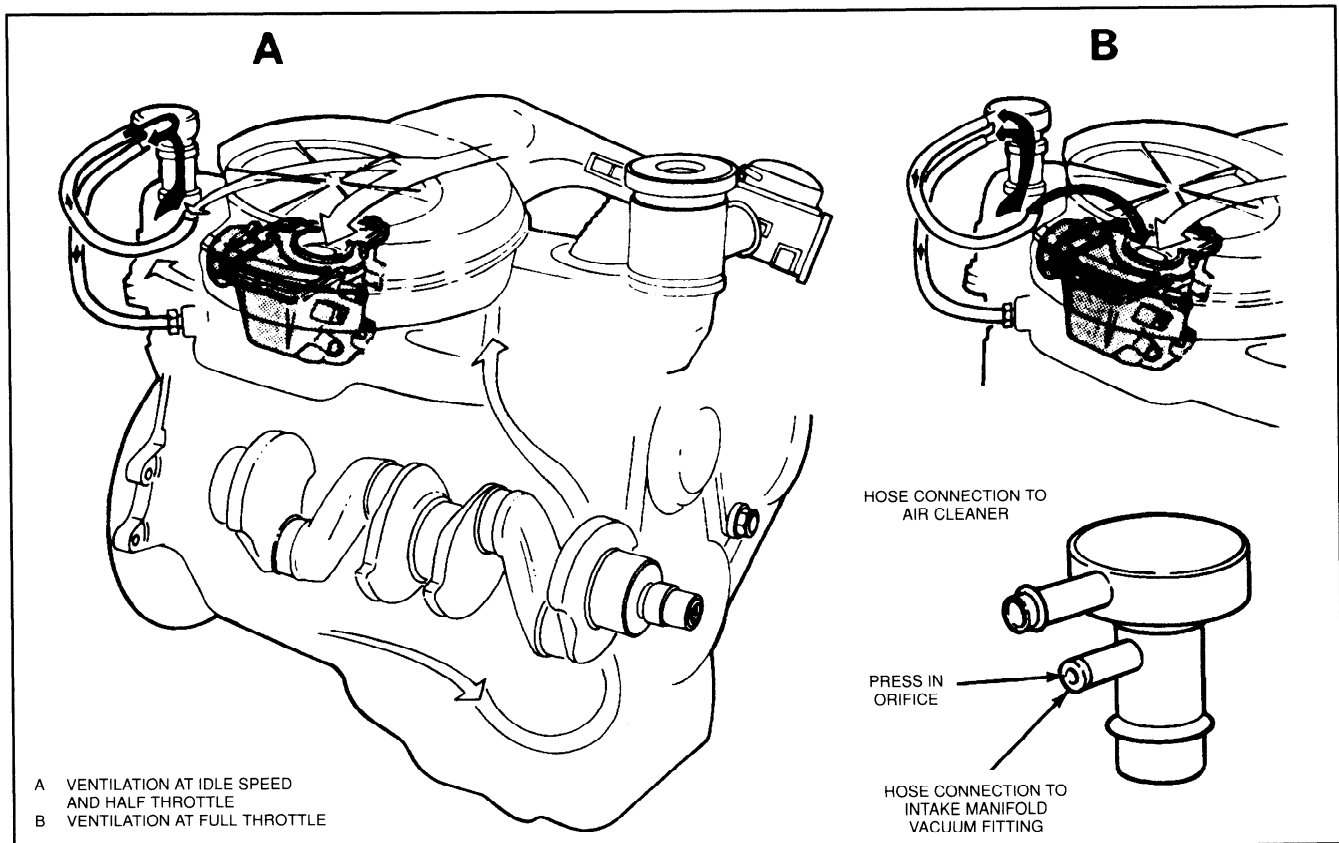

Lubrication Circuit:

An eccentric twin-rotor oil pump draws oil via a strainer from the sump and forces it into the full-flow oil filter.

Oil pressure is regulated by a relief valve inside the pump. The filtered oil passes through the center of the filter element, then along a short passage (right hand side of the engine) to the oil pressure switch and through a transverse bore to the main oil gallery (left hand side of the engine).

The crankshaft main bearings are fed directly from the main oil gallery and the camshaft bearings are linked, in turn for their lubrication with the front, center and rear main bearings. Each of the rod journals are supplied with oil by the nearest main bearing through oblique passages.

An oil hole in the connecting rod ensures splash lubrication of the piston pins and the trailing side of the cylinders. Timing chain and sprockets are also lubricated via a splash hole. The camshaft front bearing journal has a machined groove through which oil is intermittently forced to the rocker shaft (via passages in cylinder block and cylinder head).

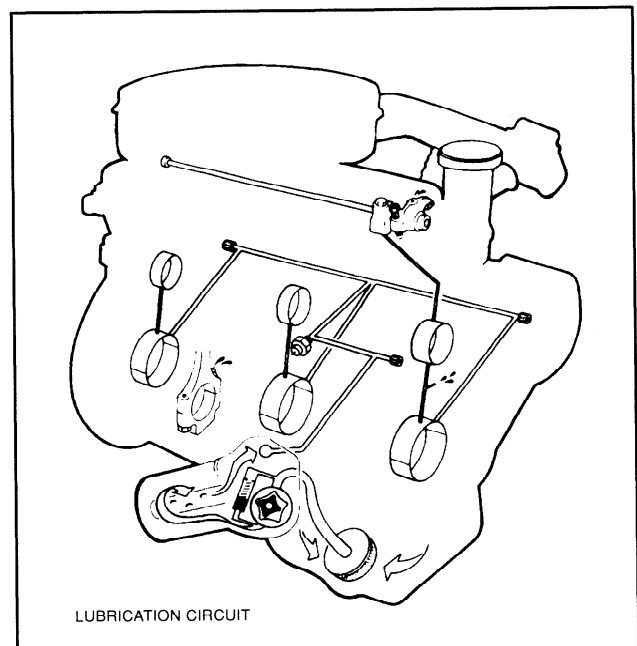

DIAGNOSIS AND TESTING

Camshaft Lobe Lift

Check the lift of each lobe in consecutive order and make a note of the readings.

1. Remove the air cleaner and the valve rocker arm cover.
2. Remove the valve rocker arm shaft assembly as detailed in the pertinent section.
3. Make sure the push rod is in the valve lifter socket. Install a dial indicator in such a manner as to have the ball socket adapter of the indicator on the end of the push rod and in the same plane as the push rod movement.

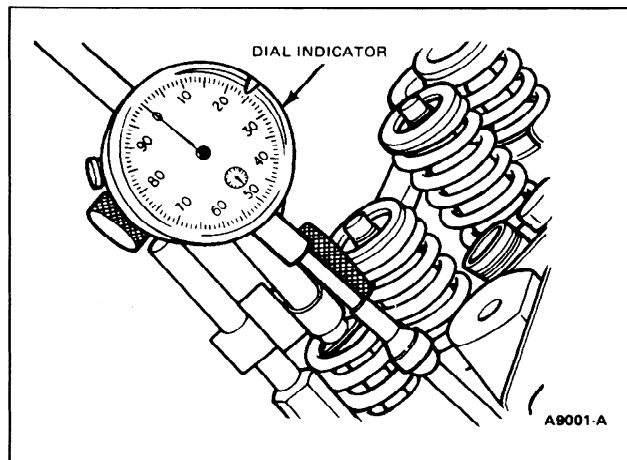

4. Connect an auxiliary starter switch in the starting circuit. Crank the engine with the ignition switch OFF. Bump the crankshaft over until the tappet or lifter is on the base circle of the camshaft lobe. At this point, the push rod will be in its lowest position.
5. Zero the dial indicator. Continue to rotate the crankshaft slowly until the push rod is in the fully raised position (highest indicator reading).
6. Compare the total lift recorded on the indicator with specifications.
7. To check the accuracy of the original indicator reading, continue to rotate the crankshaft until the indicator reads zero. **If the lift on any lobe is below specified wear limits, the camshaft and the valve lifters operating on the worn lobe(s) must be replaced.**
8. Remove the dial indicator and auxiliary starter switch.
9. Install the rocker arm shaft assembly as detailed under Removal and Installation.
10. Install the valve rocker arm cover and the air cleaner.

Compression Test

Compression Gauge Check

1. Be sure the crankcase is at the proper level and the battery is properly charged. Operate the engine for a minimum of 30 minutes at 1200 rpm or until the engine is at normal operating temperature. Turn the ignition switch off; then remove all the spark plugs.
2. Set the carburetor throttle plates and choke plate in the wide open position.
3. Install a compression gauge in No. 1 cylinder.
4. Install an auxiliary starter switch in the starting circuit. Using the auxiliary starter switch, crank the engine (with the ignition switch off) at least five compression strokes and record the highest reading.

Note the approximate number of compression strokes required to obtain the highest reading.

5. Repeat the test on each cylinder as was required to obtain the highest reading on the No. 1 cylinder.

Test Conclusion

The indicated compression pressures are considered normal if the lowest reading cylinder is within 75% of the highest. Refer to the following example.

Seventy-five percent of 140, the highest cylinder reading, is 105. Therefore, cylinder No. 7 being less than 75% of cylinder No. 3 indicates an improperly seated valve or worn or broken piston rings.

If one or more cylinders read low, squirt approximately 15 ml (one tablespoon) of engine oil on top of the pistons in the low reading cylinders. Repeat compression pressure check on these cylinders.

1. If compression improves considerably, the piston rings are at fault.
2. If compression does not improve, valves are sticking or seating poorly.
3. If two adjacent cylinders indicate low compression pressures and squirting oil on the pistons does not increase the compression, the cause may be a cylinder head gasket leak between the cylinders. Engine oil and/or coolant in the cylinders could result from this problem.

It is recommended the following quick reference chart be used when checking cylinder compression pressures. The chart has been calculated so that the lowest reading number is 75% of the highest reading.

Example

After checking the compression pressures in all cylinders, it was found that the highest reading obtained was 196 psi. The lowest pressure reading was 155 psi. The engine is within specifications and the compression is considered satisfactory.

DIAGNOSIS AND TESTING (Continued)

Maximum		Minimum		Maximum		Minimum		Maximum		Minimum	
kPa	PSI	kPa	PSI	kPa	PSI	kPa	PSI	kPa	PSI	kPa	PSI
924	134	696	101	1200	174	903	131	1476	214	1103	160
938	136	703	102	1214	176	910	132	1489	216	1117	162
952	138	717	104	1227	178	917	133	1503	218	1124	163
965	140	724	105	1241	180	931	135	1517	220	1138	165
979	142	738	107	1255	182	938	136	1531	222	1145	166
993	144	745	108	1269	184	952	138	1544	224	1158	168
1007	146	758	110	1282	186	965	140	1558	226	1165	169
1020	148	765	111	1296	188	972	141	1572	228	1179	171
1034	150	779	113	1310	190	979	142	1586	230	1186	172
1048	152	786	114	1324	192	993	144	1600	232	1200	174
1062	154	793	115	1338	194	1000	145	1613	234	1207	175
1076	156	807	117	1351	196	1014	147	1627	236	1220	177
1089	158	814	118	1365	198	1020	148	1641	238	1227	178
1103	160	827	120	1379	200	1034	150	1655	240	1241	180
1117	162	834	121	1393	202	1041	151	1669	242	1248	181
1131	164	848	123	1407	204	1055	153	1682	244	1262	183
1145	166	855	124	1420	206	1062	154	1696	246	1269	184
1158	168	869	126	1434	208	1076	156	1710	248	1282	186
1172	170	876	127	1448	210	1083	157	1724	250	1289	187
1186	172	889	129	1462	212	1089	158				

CA1005-A

Crankshaft End Play

1. Force the crankshaft toward the rear of the engine.
2. Install a dial indicator so that the contact point rests against the crankshaft flange and the indicator axis is parallel to the crankshaft axis.
3. Zero the dial indicator. Push the crankshaft forward and note the reading on the dial.
4. If the end play exceeds the wear limit, replace the thrust washers. If the end play is less than the minimum limit, inspect the thrust bearing faces for scratches, burrs, nicks, or dirt.

Flywheel Face Runout

Install a dial indicator so that the indicator point bears against the flywheel face. Turn the flywheel, making sure that it is full forward or rearward so that the crankshaft end play will not be indicated as flywheel runout.

If the clutch face runout exceeds specifications, remove the flywheel and check for burrs between the flywheel and the face of the crankshaft mounting flange. If no burrs exist, check the runout of the crankshaft mounting flange. Replace the flywheel, or machine the crankshaft-flywheel mounting face sufficiently to true up the surface if the mounting flange runout exceeds specifications. Replace it or reinstall it on the flywheel.

Camshaft End Play

Push the camshaft toward the rear of the engine. Install a dial indicator so that the indicator point is on the camshaft sprocket attaching screw or gear hub. Zero the dial indicator. Position a large screwdriver between the camshaft sprocket and the cylinder head. Pull the camshaft forward and release it. Compare the dial indicator reading with specifications. If the end play is excessive, replace the thrust plate retaining the camshaft. Remove the dial indicator.

OVERHAUL

Cylinder Head

Replace the head if it is cracked. **Do not plane or grind more than 0.25 mm (0.010 inch) from the cylinder head gasket surface.** Remove all burrs or scratches with an oil stone.

Reaming Valve Guides

If it becomes necessary to ream the valve guide, to an oversize valve always use the reamer in sequence.

Always reface the valve seat after the valve guide has been reamed, and use a suitable scraper to break the sharp corner (ID) at the top of the valve guide.

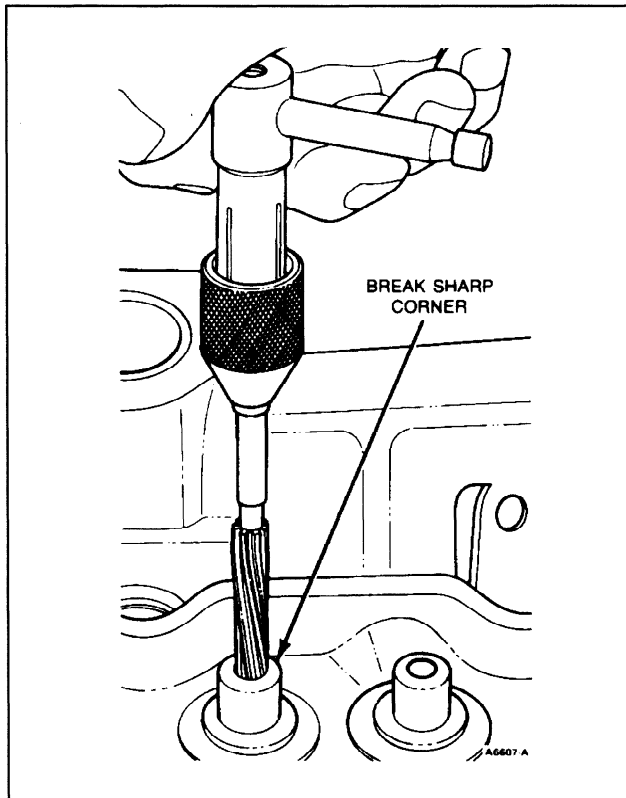

Refacing Valve Seats

Refacing of the valve seat should be closely coordinated with the refacing of the valve face so that the finished seat and valve face will be concentric and the specified interference fit will be maintained. This is important so that the valve and seat will have a compression-tight fit. Be sure that the refaced grinding wheels are properly dressed.

Grind the valve seats to a true 45 degree angle. Remove only enough stock to clean up pits and grooves or to correct the valve seat runout. After the seat has been refaced, use a seat width scale or a machinist scale to measure the seat width. Narrow the seat, if necessary, to bring it within specifications.

If the valve seat width exceeds the maximum limit, remove enough stock from the top edge and/or bottom edge of the seat to reduce the width to specifications.

On the valve seats of all engines, use a 60 degree angle grinding wheel to remove stock from the bottom of the seats (raise the seats) and use a 30 degree angle wheel to remove stock from the top of the seats (lower the seats).

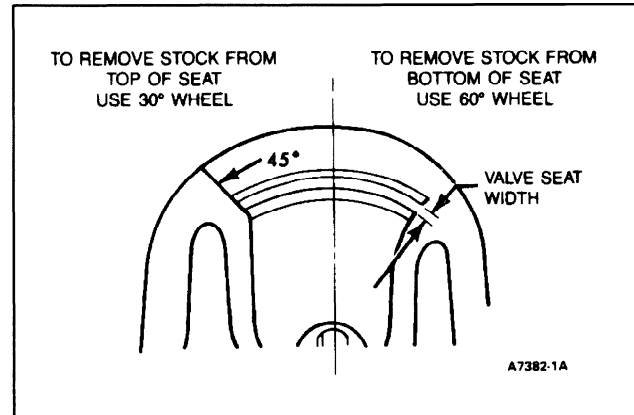

The finished valve seat should contact the approximate center of the valve face. It is good practice to determine where the valve seat contacts the face. To do this, coat the seat with Prussian blue and set the valve in place. Rotate the valve with light pressure. If the blue is transferred to the center of the valve face, the contact is satisfactory. If the blue is transferred to the top edge of the valve face, lower the valve seat. If the blue is transferred to the bottom edge of the valve face, raise the valve seat.

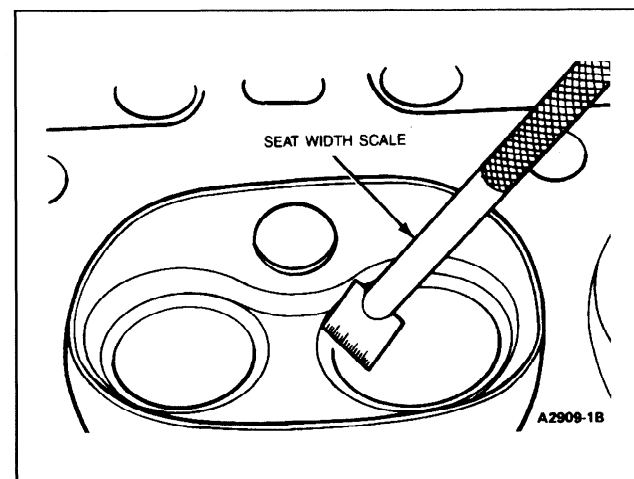

Valves

Minor pits, grooves, etc., may be removed. Discard valves that are severely damaged, if the face runout cannot be corrected by refinishing or stem clearance exceeds specifications. Discard **any excessively worn or damaged valve train parts.**

Refacing Valves

The valve refacing operation should be closely coordinated with the valve seat refacing operations so that the finished angles of the valve face and of the valve seat will be to specifications and provide a compression-tight fit. Be sure that the refaced grinding wheels are properly dressed.

OVERHAUL (Continued)

Under no circumstances should the faces of aluminized intake valves be ground or the valves lapped in as this will remove the diffused aluminum coating and reduce the valves' wear and heat resistant properties. If the valve faces are worn or pitted it will be necessary to install new valves and to resurface the valve seats or, alternatively, lap the seats using dummy valves. The exhaust valves may be lapped in or the faces ground if required.

If the valve face runout is excessive and/or to remove pits and grooves, reface the valves to a true 44 degree angle. Remove only enough stock to correct the runout or to clean up the pits and grooves. If the edge of the valve head is less than 0.8 mm (1/32 inch) thick after grinding, replace the valve as the valve will run too hot in the engine. **The interference fit of the valve and seat should not be lapped out. Remove all grooves or score marks from the end of the valve stem, and chamfer it as necessary. Do not remove more than 0.25 mm (0.010 inch) from the end of the valve stem.**

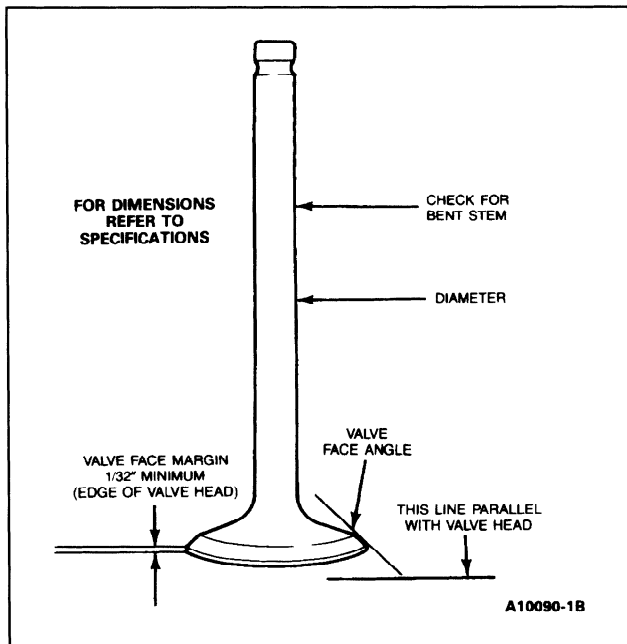

If the valve and/or valve seat has been refaced, it will be necessary to check the clearance between the rocker arm pad and the valve stem with the valve train assembly installed in the engine.

Select Fitting Valves

If the valve stem to valve guide clearance exceeds the wear limit, ream the valve guide for the **next** oversize valve stem. Valves with oversize stem diameter are available for service.

Always reface the valve seat after the guide has been reamed. Refer to Reaming Valve Guides.

Camshaft Repair

Remove light scuffs, scores or nicks from the camshaft machined surfaces with a smooth oil stone.

Crankshaft

Dress minor scores with an oil stone. If the journals are severely marred or exceed the wear limit, they should be refinished to size for the next undersize bearing.

Refinishing Journals

Refinish the journals to give the proper clearance with the next undersize bearing. If the journal will not clean up to maximum undersize bearing available, replace the crankshaft.

Always reproduce the same journal shoulder radius that existed originally. Too small a radius will result in fatigue failure of the crankshaft. Too large a radius will result in bearing failure due to radius ride of the bearing.

After refinishing the journals, chamfer the oil holes; then polish the journal with a No. 320 grit polishing cloth and engine oil. Crocus cloth may also be used as a polishing agent.

Fitting Main or Connecting Rod Bearings With Plastigage

1. Clean crankshaft journals. Inspect journals and thrust faces (thrust bearing) for nicks, burrs or bearing pickup that would cause premature bearing wear. **When replacing standard bearings with new bearings, it is good practice to fit the bearing to minimum specified clearance.** If the desired clearance cannot be obtained with a standard bearing, try a 0.05 mm (0.002 inch) undersize in combination with a standard bearing to obtain the proper clearance.
2. If fitting a main bearing in the chassis, **position a jack under the counterweight adjoining bearing which is being checked. Support crankshaft with jack so its weight will not compress Plastigage and provide an erroneous reading.**
3. Place a piece of Plastigage on bearing surface across full width of bearing cap and about 6.4 mm (1/4 inch) off center.

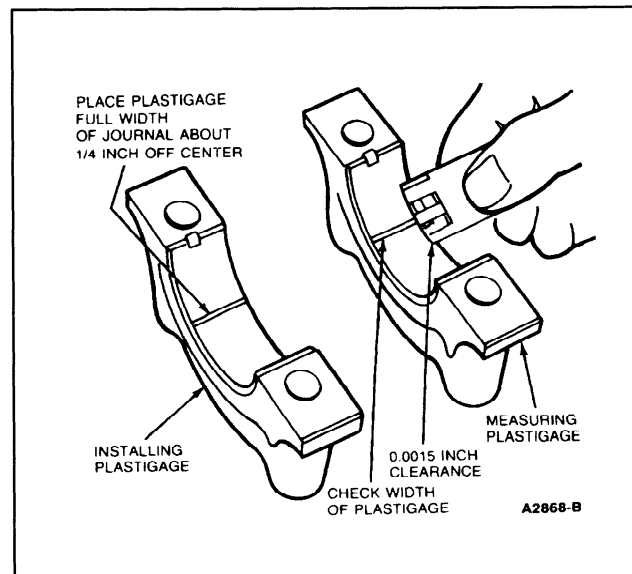

OVERHAUL (Continued)

4. Install cap and torque bolts to specifications. Do not turn crankshaft while Plastigage is in place.
5. Remove cap. Using Plastigage scale, check width of Plastigage at widest point to get minimum clearance. Check at narrowest point to get maximum clearance. Difference between readings is taper of journals.
6. If clearance exceeds specified limits on the connecting rod bearings, try a 0.05 mm (0.002 inch) undersize bearing in combination with the standard bearings. Bearing clearance must be within specified limits. If 0.05 mm (0.002 inch) undersize main bearings are used on more than one journal, be sure they are all installed in cylinder block side of bearing. If standard and 0.05 mm (0.002 inch) undersize bearings do not bring clearance within desired limits, refinish crankshaft journal, then install undersize bearings.
7. After bearing has been fitted, remove Plastigage, apply light coat of engine oil to journal and bearings. Install bearing cap. Torque cap bolts to specifications.
8. Repeat procedure for remaining bearings that require replacement.

Pistons, Pins and Rings

Fitting Pistons

Pistons are available for service in standard sizes and the oversizes shown in the parts list.

Measure the piston diameter to ensure that the specified clearance is obtained. It may be necessary periodically to use another piston that is either slightly larger or smaller to achieve the specified clearance. **If none can be fitted, refinish the cylinder to provide the proper clearance for the piston. When a piston has been fitted, mark it for assembly in the cylinder to which it was fitted. If the taper, out-of-round and piston to cylinder bore clearance conditions of the cylinder bore are within specified limits, new piston rings will give satisfactory service. If new rings are to be installed in a used cylinder that has not been refinished, remove the cylinder wall glaze (Refer to Cylinder Block, Refinishing Cylinder Walls). Be sure to clean the cylinder bore thoroughly.**

1. Calculate the size piston to be used by taking a cylinder bore check. Follow the procedures outlined under Cleaning and Inspection.
2. Select the proper size piston to provide the desired clearance (refer to the specifications). The piston should be measured 57.2 mm (2-1/4 inches) below the dome and at 90° to the piston pin bore.
3. Make sure the piston and cylinder block are at room temperature 21 degrees C (70 degrees F). **After any refinishing operation allow the cylinder bore to cool, and make sure the piston and bore are clean and dry before the piston fit is checked.**

Fitting Piston Rings

Three piston rings are fitted, two compression and one oil control ring.

1. Select the proper ring set for the size cylinder bore.
2. Position the ring in the cylinder bore in which it is going to be used.
3. Push the ring down into the bore area where normal ring wear is not encountered.
4. Use the head of a piston to position the ring in the bore so that the ring is square with the cylinder wall. **Use caution to avoid damage to the ring or cylinder bore.**
5. Measure the gap between the ends of the ring with a feeler gauge. If the ring gap is less or greater than the specified limits, try another ring set.

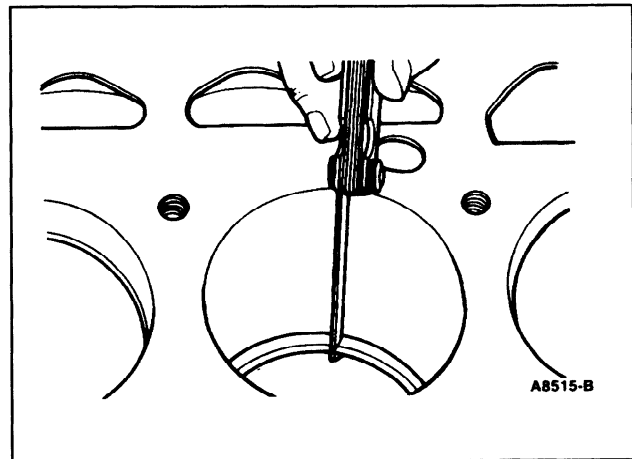

6. Check the ring side clearance of the compression rings with a feeler gauge inserted between the ring and its lower land. The gauge should slide freely around the entire ring circumference without binding. Any wear that occurs will form a step at the inner portion of the lower land. **If the lower lands have high steps, the piston should be replaced.**

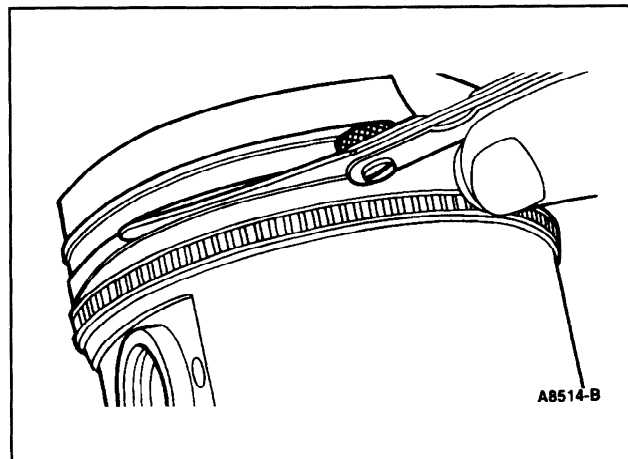

OVERHAUL (Continued)

Fitting Piston Pins

The piston pins are selected to give the correct fit in the piston pin bore and bushing in the connecting rod. Pistons are only supplied in service complete with the piston pin, to ensure the correct fit. The piston pins should not be interchanged.

Valve Rocker Arm and/or Shaft Assembly

Dress up minor surface defects on the rocker arm shaft and in the rocker arm bore with a hone.

If the pad at the valve end of the rocker arm has a grooved radius, replace the rocker arm. **Do not attempt to true this surface by grinding.**

Push Rods

Following the procedures under Push Rod Inspection, check the push rods for straightness.

If the runout exceeds the maximum limit at any point, discard the rod. **Do not attempt to straighten push rods.**

Cylinder Block

Refinishing Cylinder Walls

Honing is recommended for refinishing cylinder walls **only** when the walls have minor scuffs or scratches, or for fitting pistons to the specified clearance. The grade of hone to be used is determined by the amount of metal to be removed. Follow the instructions of the hone manufacturer. If coarse stones are used to start the honing operation, leave enough material so that all hone marks can be removed with the finishing hone which is used to obtain the proper piston clearance. Cylinder walls that are severely marred and/or worn beyond the specified limits should be refinished. **Before any cylinder is refinished, all main bearing caps must be in place and tightened to the proper torque so that the crankshaft bearing bores will not become distorted from there finishing operation.** Refinish only the cylinder or cylinders that require it. All pistons are the same weight, both standard and oversize; therefore, various sizes of pistons can be used without upsetting engine balance. Refinish the cylinder with the most wear first to determine the maximum oversize. If the cylinder will not clean up when refinished for the maximum oversize piston recommended, replace the block. Refinish the cylinder to within approximately 0.04 mm (0.0015 inch) of the required oversize diameter. This will allow enough stock for the final step of honing so that the correct surface finish and pattern are obtained. For the proper use of the refinishing equipment follow the instructions of the manufacturer. Only experienced personnel should be allowed to perform this work. Use a motor-driven, spring pressure-type hone at a speed of 300-500 rpm. Hones of grit sizes 180-220 will normally provide the desired bore surface finish of 15/32 RMS. When honing the cylinder bores use a lubricant mixture of equal parts of kerosene and SAE No. 20 motor oil. Operate the hone in such a way to produce a cross-hatch finish on the cylinder bore. The

cross-hatch pattern should be at an angle of approximately 30 degrees to the cylinder bore. After the final operation in either of the two refinishing methods described and prior to checking the piston fit, thoroughly clean and oil the cylinder walls. Mark the pistons to correspond to the cylinders in which they are to be installed. When the refinishing of all cylinders that require it has been completed and all pistons are fitted, thoroughly clean the entire block and oil the cylinder walls.

Repairing Sand Holes or Porous Engine Castings

Porosity or sand hole(s) which will cause oil seepage or leakage can occur with modern casting processes. A complete inspection of engine and transmission should be made. If the leak is attributed to the porous condition of the cylinder block or sand hole(s), repairs can be made with metallic plastic (part No. C6AZ-19554-A). **Do not repair cracks with this material.** Repairs with this metallic plastic must be confined to those cast iron engine component surfaces where the inner wall surface is not exposed to engine coolant pressure or oil pressure. For example:

1. Cylinder block surfaces extending along the length of the block, upward from the oil pan rail to the cylinder water jacket but not including machined areas.
2. Lower rear face of the cylinder block.
3. Intake manifold casting.
4. Cylinder head, along the rocker arm cover gasket surface.

The following procedure should be used to repair porous areas or sand holes in cast iron.

1. Clean the surface to be repaired by grinding or rotary filing to a clean bright metal surface. Chamfer or undercut the hole or porosity to a greater depth than the rest of the cleaned surface. Solid metal must surround the hole. Openings larger than 6.4 mm (1/4 inch) should not be repaired using metallic plastic. Openings in excess of 6.4 mm (1/4 inch) can be drilled, tapped and plugged using common tools. Clean the repair area thoroughly. Metallic plastic will not stick to a dirty or oily surface.
2. Mix the metallic plastic base and hardener as directed on the container. Stir thoroughly until uniform.
3. Apply the repair mixture with a suitable clean tool, (putty knife, wood spoon, etc.) forcing the epoxy into the hole or porosity.
4. Allow the repair mixture to harden. This can be accomplished by two methods, heat cure with a 121 degrees C (250 degrees F) lamp placed 254 mm (10 inches) from the repaired surface, or air dry for 10-12 hours at temperatures above 10 degrees C (50 degrees F).
5. Sand or grind the repaired area to blend with the general contour of the surrounding surface.
6. Paint the surface to match the rest of the block.

CLEANING AND INSPECTION

The cleaning and inspection procedures are for a complete engine overhaul; therefore, for partial engine overhaul or parts replacement, follow the pertinent cleaning or inspection procedure.

Intake Manifold

Cleaning

Remove all gasket material from the machined surfaces of the manifold. Clean the manifold in a suitable solvent and dry it with compressed air.

Inspection

Inspect the manifold for cracks, damaged gasket surfaces, or other defects that would make it unfit for further service. Replace all studs that are stripped or otherwise damaged.

Remove all filings and foreign matter that may have entered the manifold as a result of repairs.

Exhaust Manifolds

Cleaning

Remove all gasket material from the manifolds.

Inspection

Inspect the cylinder head joining flanges of the exhaust manifold for evidence of exhaust gas leaks.

Inspect the manifolds for cracks, damaged gasket surfaces, or other defects that would make them unfit for further service.

Valve Rocker Arm and/or Shaft Assembly

Cleaning

Clean all the parts thoroughly. Make sure all oil passages are open.

Make sure the oil passage in the rocker arm is open.

Inspection

On rocker arm shaft assemblies, check the clearance between each rocker arm and the shaft by checking the ID of the rocker arm bore and the OD of the shaft. If the clearance between any rocker arm and the shaft exceeds the wear limit, replace the shaft and/or the rocker arm. Inspect the shaft and the rocker arm bore for nicks, scratches, scores or scuffs.

Inspect the pad at the valve end of the rocker arm for indications of scuffing or abnormal wear. If the pad is grooved, replace the rocker arm. **Do not attempt to true this surface by grinding.**

Check the adjusting nut(s) torque. If not within specifications, replace the nut(s). Check the rocker arm pad and fulcrum seat for excessive wear, cracks, nicks or burrs.

Push Rods

Cleaning

Clean the push rods in a suitable solvent. Blow dry the push rod with compressed air.

Inspection

Check the ends of the push rods for nicks, grooves, roughness or excessive wear.

The push rods can be visually checked for straightness while they are installed in the engine by rotating them with the valve closed. They also can be checked with a dial indicator.

If the push rod is visibly bent, it should be replaced.

Cylinder Heads

Cleaning

With the valves installed to protect the valve seats, remove deposits from the combustion chambers and valve heads with a scraper and a wire brush. Be careful not to damage the cylinder head gasket surface. After the valves are removed, clean the valve guide bores with a valve guide cleaning tool. Use cleaning solvent to remove dirt, grease and other deposits. Clean all bolt holes. Remove all deposits from the valves with a fine wire brush or buffing wheel.

Inspection

Check the cylinder head for cracks and inspect the gasket surface for burrs and nicks. Replace the head if it is cracked.

The following inspection procedures are for a cylinder head that is to be completely overhauled. For individual repair operations, use only the pertinent inspection procedure.

When a cylinder head is removed because of gasket leaks, check the flatness of the cylinder head gasket surface for conformance to specifications. If necessary to refinish the cylinder head gasket surface, **do not plane or grind off more than 0.25 mm (0.010 inch).**

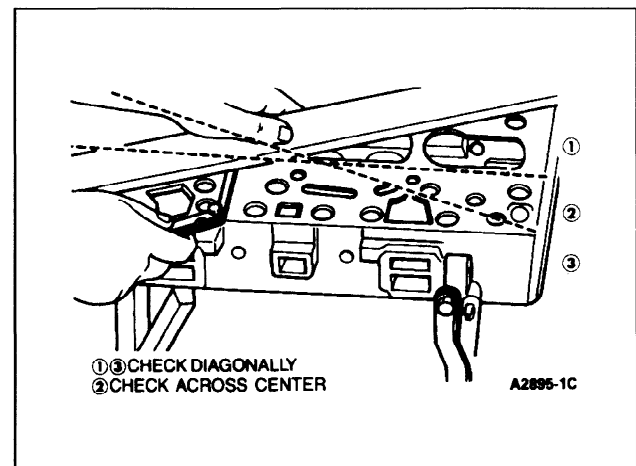

CLEANING AND INSPECTION (Continued)

Check the valve seat runout with an accurate gauge. Follow the instructions of the gauge manufacturer. If the runout exceeds the wear limit, reface the valve and valve seat. Measure the valve seat width. Reface any valve seat whose width is **not within specifications**.

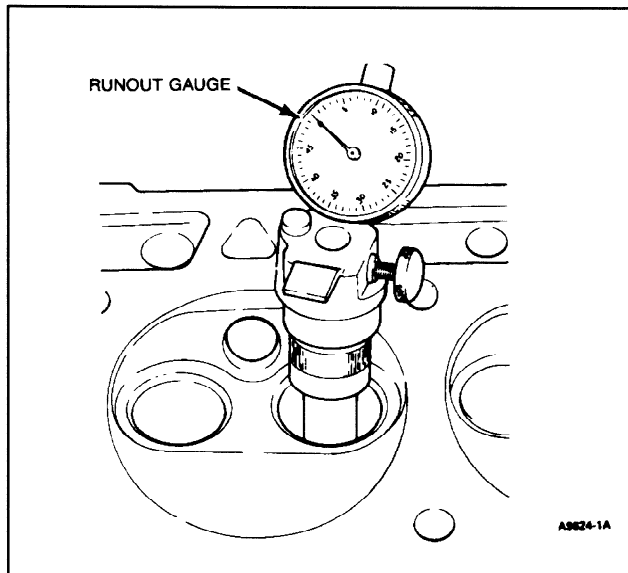

Inspect the valve face and the edge of the valve head for pits, grooves, scores or other damage. Inspect the stem for a bent condition and the end of the valve head for pits, grooves, scores or other wear. Inspect the stem for a bent condition and the end of the stem for grooves or scores. Check the valve head for signs of burning, erosion, warpage and cracking. Minor pits, grooves, etc., may be removed. Discard valves that are severely damaged.

Inspect the valve spring, valve spring retainers, locks and sleeves for wear or damage. Discard any visually damaged parts.

Check the valve stem to valve guide clearance of each valve in its respective valve guide with the tool shown below, or its equivalent. Use a flat end indicator point.

With the cylinder head gasket face up, slide a new standard intake or exhaust valve into the valve guide to be checked until the tip of the valve stem is flush with the top of the valve guide.

Mount a dial test indicator on the cylinder head by the valve to be checked.

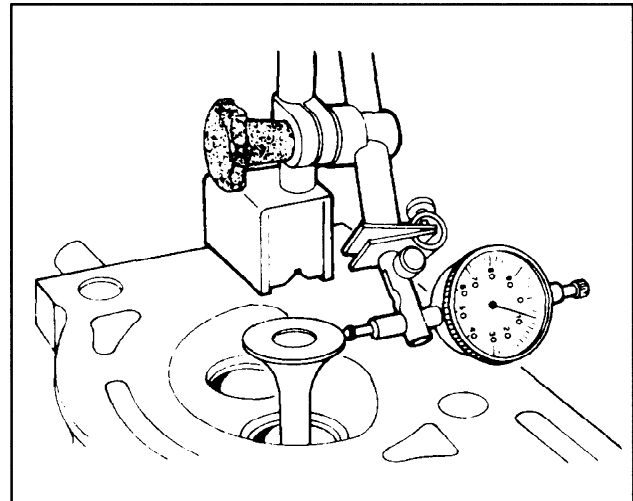

Position the plunger of the dial test indicator on the edge of the valve head and measure the valve head movement by applying lateral pressure to the valve. If the valve head movement is greater than the values given below, the valve guide in question must be reamed using the appropriate reamer, and a new oversize valve installed.

Maximum permissible valve head movement values for the above test procedure:

Intake valve	0.50 mm (0.020 in.)
Exhaust valve	0.60 mm (0.024 in.)

Check the springs for proper pressure at the specified spring lengths. (Tool 6513-DD.) **Manually rotating the valve spring assemblies while installed in the engine, must not be used to determine good and/or bad valve springs.** Weak valve springs cause poor engine performance. Replace any spring not within specifications.

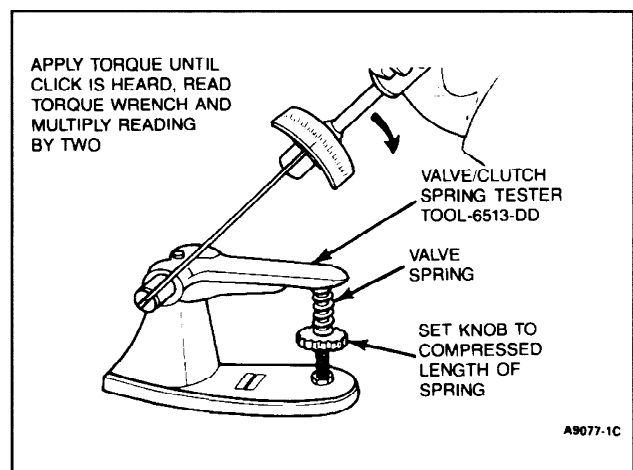

CLEANING AND INSPECTION (Continued)

Check each spring for squareness, using a steel square and a flat surface. Stand the spring and square on end on the flat surface. Slide the spring up to the square. Revolve the spring slowly and observe the space between the top coil of the spring and the square. The out-of-square limits are 2 mm (5/64 inch).

Follow the same procedure to check new valve springs before installation. **Make certain the proper spring (color coded) is installed.**

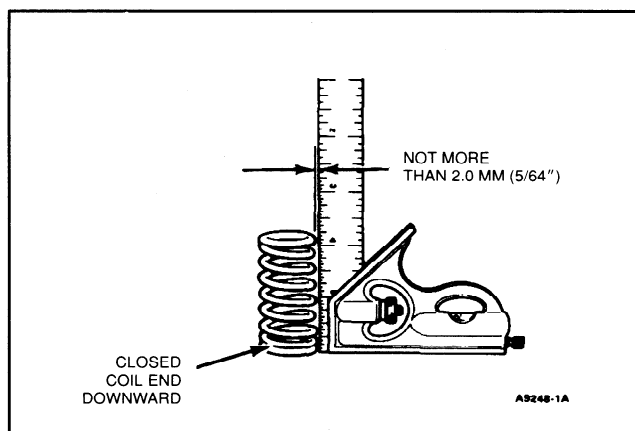

Tappets

Cleaning

Thoroughly clean the tappets in cleaning solvent and wipe them with a clean lint-free cloth.

Inspection

Check the tappets for wear or scores. Check the bottom end of tappet to make sure that it has a slight convex. Replace tappets that are scored, worn, or if the bottom is not smooth. If the bottom surface is worn flat, it may be used with the original camshaft only.

Timing Chain and Sprockets

Cleaning

Clean all parts in solvent and dry them with compressed air. Lubricate the timing chain with engine oil before installing it on the sprockets.

Inspection

Inspect the chain for broken links. Inspect the sprockets for cracks and worn or damaged teeth. Replace all the components of the timing chain and sprocket assembly, if any one item needs replacement.

Camshaft

Cleaning

Clean the camshaft in solvent and wipe it dry.

Inspection

Inspect the camshaft lobes for scoring and signs of abnormal wear. Lobe pitting except in the general area

of the lobe toe is not detrimental to the operation of the camshaft; therefore, the camshaft should not be replaced unless the lobe lift loss has exceeded specifications or pitting has occurred in the lobe lift area.

The lift of the camshaft lobes can be checked with the camshaft installed in the engine or on centers. Refer to Camshaft Lobe Lift.

To measure the camshaft lobe lift proceed as follows:

1. Measure distance between the major (A-A) and minor (B-B) diameters of each cam lobe with a Vernier caliper and record the readings. The difference in the readings on each cam diameter is the lobe lift.

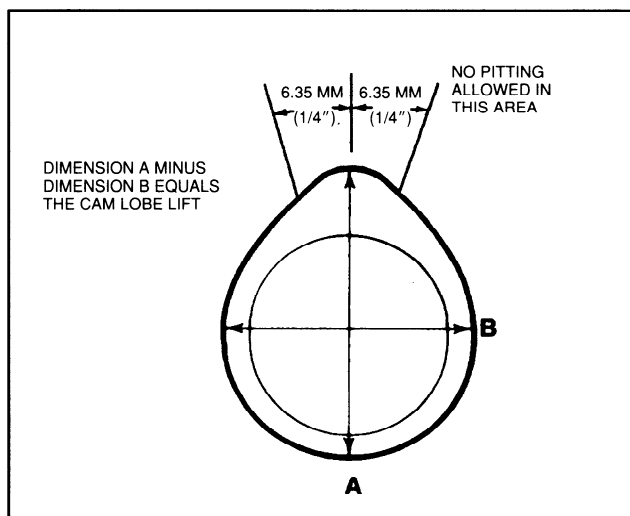

2. If the readings do not meet specification, replace the camshaft.

Camshaft Bores

Inspection

Check camshaft bores for size, taper, roundness, runout, and finish. If any of these dimensions exceeds the limits given in Specifications, install new camshaft bearings.

Crankshaft

Cleaning

Handle the crankshaft with care to avoid possible fractures or damage to the finished surfaces. Clean the crankshaft with solvent, then blow out all oil passages with compressed air.

Inspection

Inspect the main and connecting rod journals for cracks, scratches, grooves or scores. Inspect the crankshaft oil seal surface for nicks, sharp edges or burrs that might damage the oil seal during installation or cause premature seal wear.

Measure the diameter of each journal in at least four places to determine an out-of-round, taper or undersize condition.

CLEANING AND INSPECTION (Continued)

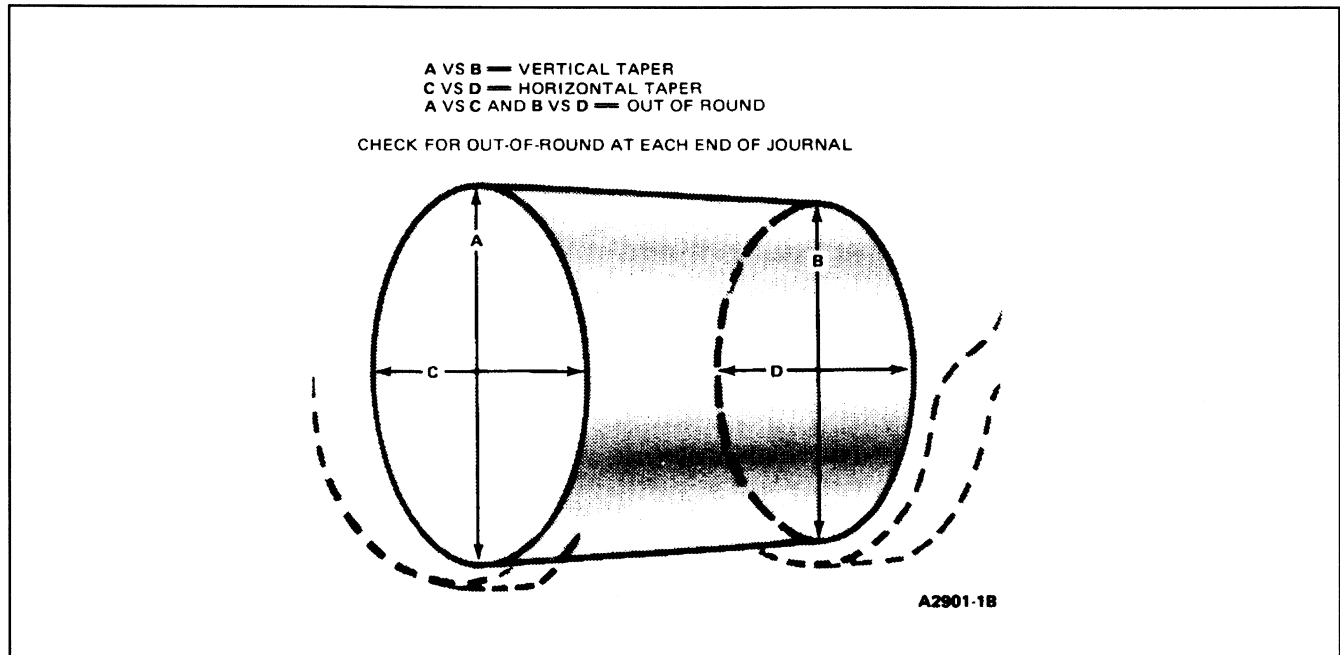

Flywheel

Inspection

Inspect the flywheel for cracks, heat check, or other damage that would make it unfit for further service. Machine the friction surface of the flywheel if it is scored or worn. If it is necessary to remove more than 1.14 mm (0.045 inch) of stock from the original thickness, replace the flywheel.

Inspect the ring gear for worn, chipped, or cracked teeth. If the teeth are damaged, replace the ring gear.

With the flywheel installed on the crankshaft, check the flywheel face runout, following the procedure under Diagnosis and Testing.

Connecting Rods

Cleaning

Removing the bearing from the rod and cap. Identify the bearing if they are to be used again. Clean the connecting rod in solvent, including the rod bore and the back of the inserts. **Do not use a caustic cleaning solution.** Blow out all passages with compressed air.

Inspection

The connecting rods and related parts should be carefully inspected and checked for conformance to specifications. Various forms of engine wear caused by these parts can be readily identified.

A shiny surface on either pin boss side of the piston usually indicates that a connecting rod is bent.

Abnormal connecting rod bearing wear can be caused by either a bent connecting rod, worn or damaged crankpin, or a tapered connecting rod bore.

Twisted connecting rods will not create an identifiable wear pattern, but badly twisted rods will disturb the action of the entire piston, rings and connecting rod assembly and may be the cause of excessive oil consumption.

Inspect the connecting rods for signs of fractures and the bearing bores for out-of-round and taper. If the bore exceeds the recommended limits and/or if the connecting rod is fractured, it should be replaced. Check the ID of the connecting rod piston pin bore. If the pin bore in the connecting rod is larger than specifications, install a 0.05 mm (0.002 inch) oversize piston pin. First, prefit the oversize piston pin to the piston pin bore by reaming or honing the piston. Then, assemble the piston, piston pin and connecting rod following the procedures for assembly. **It is not necessary to ream or hone the pin bore in the connecting rod. Replace damaged connecting rod nuts and bolts. Check the connecting rods for bend or twist on a suitable alignment fixture. Follow the instructions of the fixture manufacturer. If the bend and/or twist exceeds specifications, the connecting rod must be straightened or replaced.**

CLEANING AND INSPECTION (Continued)

Pistons, Pins and Rings

Cleaning

Remove deposits from the piston surfaces. Clean gum or varnish from the piston skirt, piston pins and rings with solvent. **Do not use a caustic cleaning solution or a wire brush to clean pistons.**

Clean the ring grooves with a ring groove cleaner. Make sure the oil ring slots (or holes) are clean.

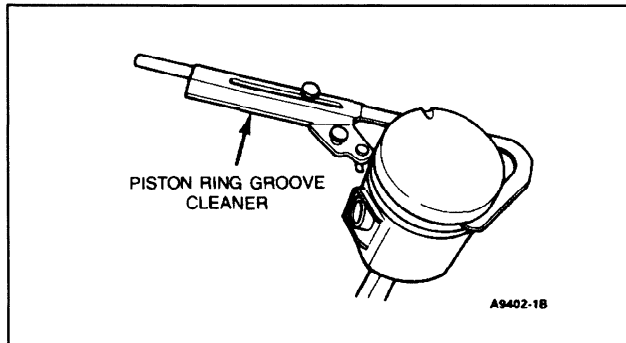

Inspection

Carefully inspect the pistons for fractures at the ring lands, skirts and pin bosses, and for scuffed, rough or scored skirts. If the lower inner portion of the ring grooves has a high step, replace the piston. The step will interfere with ring operation and cause excessive ring side clearance.

Spongy, eroded areas near the edge of the top of the piston are usually caused by detonation or pre-ignition. A shiny surface on the thrust surface of the piston, offset from the centerline between the piston pin holes, can be caused by a bent connecting rod. Replace pistons that show signs of excessive wear, wavy ring lands or fractures or damage from detonation or pre-ignition.

Check the piston to cylinder bore clearance by measuring the piston and bore diameters. Refer to the specifications for the proper clearance. Refer to Cylinder Block Inspection for the bore measurement procedure. **Measure the OD of the piston with micrometers approximately 57.2 mm (2-1/4 inches) below the dome and at 90 degrees to the piston pin bore.** Check the ring side clearance.

Replace piston pins showing signs of fracture, etching or wear. Check the piston pin fit in the piston and rod. Refer to Piston and Connecting Rod Assembly.

Check the OD of the piston pin and the ID of the pin bore in the piston. Replace any piston pin or piston that is not within specifications.

Replace all rings that are scored, broken, chipped or cracked. Check the end gap and side clearance. **Rings should not be transferred from one piston to another regardless of mileage or hours.**

Main and Connecting Rod Bearings

Cleaning

Clean the bearing inserts and caps thoroughly in solvent, and dry them with compressed air. **Do not scrape gum or varnish deposits from the bearing shells.**

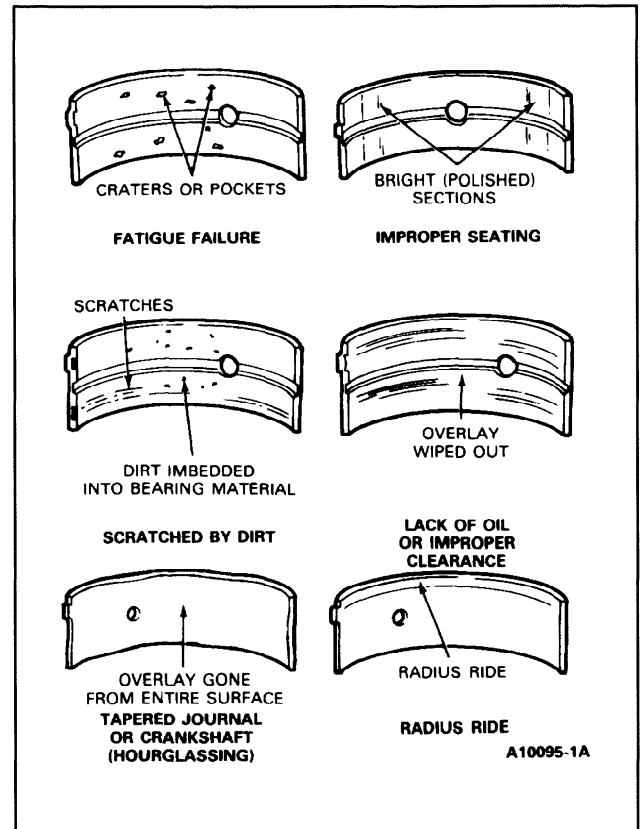

Inspection

Inspect each bearing carefully. Bearings that have a scored, chipped, or worn surface should be replaced. The copper lead bearing base may be visible through the bearing overlay. This does not mean that the bearing is worn. It is not necessary to replace the bearing if the bearing clearance is within recommended limits. Check the clearance of bearings that appear to be satisfactory with Plastigage as detailed under Overhaul — Main and Connecting Rod Bearings.

Cylinder Block

Cleaning

After any cylinder bore repair operation, such as honing or deglazing, clean the bore(s) with soap or detergent and water. Then, thoroughly rinse the bore(s) with clean water to remove the soap or detergent, and wipe the bore(s) dry with a clean, lint-free cloth. Finally wipe the bore(s) with a clean cloth dipped in engine oil. If these procedures are not followed, rusting of the cylinder bore(s) may occur.

CLEANING AND INSPECTION (Continued)

If the engine is disassembled, thoroughly clean the block with solvent. Remove old gasket material from all machined surfaces. Remove all pipe plugs that seal oil passages; then clean out all the passages, bolt holes, etc., with compressed air. Make sure the threads in the cylinder head bolt holes are clean. Dirt in the threads may cause binding and result in a false torque reading. Use a tap to true up threads and to remove any deposits. Thoroughly clean the grooves in the crankshaft bearing and bearing retainers.

Inspection

After the block has been thoroughly cleaned, check it for cracks. Minute cracks not visible to the naked eye may be detected by coating the suspected area with a mixture of 25% kerosene and 75% light engine oil. Wipe the part dry and immediately apply a coating of zinc oxide dissolved in wood alcohol. If cracks are present, the coating will become discolored at the defective area. Replace the block if it is cracked.

Check all machined gasket surfaces for burrs, nicks, scratches and scores. Remove minor imperfections with an oil stone.

Replace all expansion-type plugs that show evidence of leakage.

Inspect the cylinder walls for scoring, roughness, or other signs of wear. Check the cylinder bore for out-of-round and taper. Measure the bore with an accurate bore gauge following the instructions of the manufacturer. Measure the diameter of each cylinder bore at the top, middle and bottom with the gauge placed at right angles and parallel to the centerline of the engine. **Use only the measurements obtained at 90 degrees to the engine centerline when calculating the piston to cylinder bore clearance.**

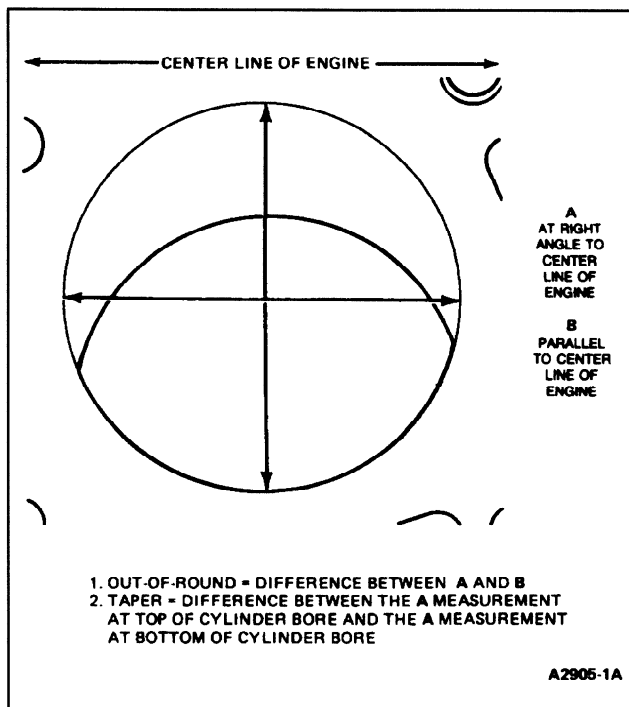

Refinish cylinders that are deeply scored and/or when out-of-round and/or taper exceed the wear limits. If the cylinder walls have minor surface imperfections, but the out-of-round and taper are within limits, it may be possible to remove the imperfections by honing the cylinder walls and installing new service piston rings providing the piston clearance is within specified limits.

Oil Pan

Cleaning

Scrape any dirt or metal particles from the inside of the pan. Scrape all old gasket material from the gasket surface. Wash the pan in a solvent and dry it thoroughly. Be sure all foreign particles are removed from below the baffle plate.

Inspection

Check the pan for cracks, holes, damaged drain plug threads, and a loose baffle or a damaged gasket surface.

Inspect for damage (uneven surface) at the bolt holes caused by over-torquing the bolts. Straighten surfaces as required. Repair any damage, or replace the pan if repairs cannot be made satisfactorily.

Oil Pump

Cleaning

Wash all parts in a solvent and dry them thoroughly with compressed air. Use a brush to clean the inside of the pump housing and the pressure relief valve chamber. Be sure all dirt and metal particles are removed.

Inspection

Refer to the specifications for clearances and wear limits.

Check the inside of the pump housing and the outer race and rotor for damage or excessive wear.

Check the mating surface of the pump cover for wear. If the cover mating surface is worn, scored or grooved, replace the cover.

Measure the outer race to housing clearance. Then check the clearance between the outer race and the rotor lobes.

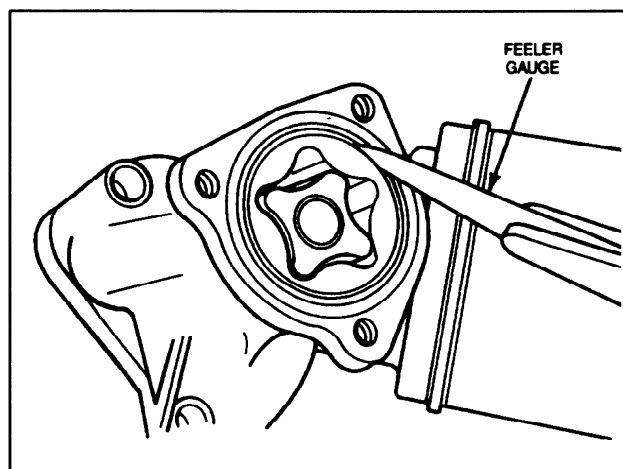

CLEANING AND INSPECTION (Continued)

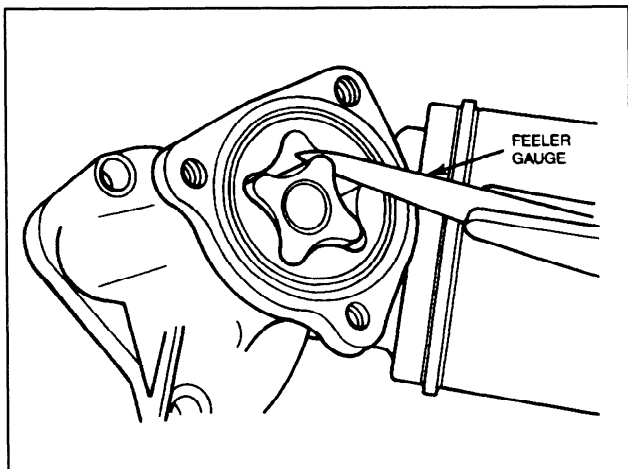

With the rotor assembly installed in the housing, place a straight edge over the rotor assembly and the housing. Measure the clearance (rotor end play) between the straight edge and the rotor and outer race. **The outer race, shaft and rotor are replaceable only as an assembly.** Check the drive shaft to housing bearing clearance by

measuring the OD of the shaft and the ID of the housing bearing. Inspect the relief valve spring for a collapsed or worn condition. Check the relief valve spring tension. If the spring is worn or damaged, replace the spring. Check the relief valve piston for scores and free operation in the bore.

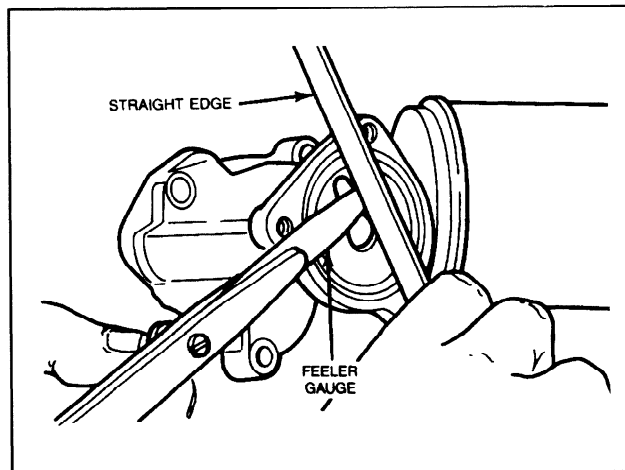

REMOVAL AND INSTALLATION

Valve Rocker Arm Cover, Rocker Arm and/or Shaft

Removal

1. Remove the air cleaner from the carburetor.
2. Disconnect the spark plug leads, remove them from the clip on the rocker cover and position aside.
3. Remove the rocker cover attaching screws, remove the rocker cover and discard the gasket.
4. Remove the rocker arm shaft attaching bolts evenly and lift off the rocker arm shaft assembly.
5. Remove the cotter pin from one end of the shaft and slip the flat washer, crimped washer and second flat washer off the shaft. The rocker arm shaft supports, rocker arms and springs can now be removed from the shaft.
6. Remove the plugs from the rocker shaft ends by drilling a hole in one plug. Insert a long rod through the drilled plug and knock the opposite plug out of the shaft. Remove the drilled plug in the same manner.
7. Clean the component parts of the shaft assembly in any suitable degreasing fluid.

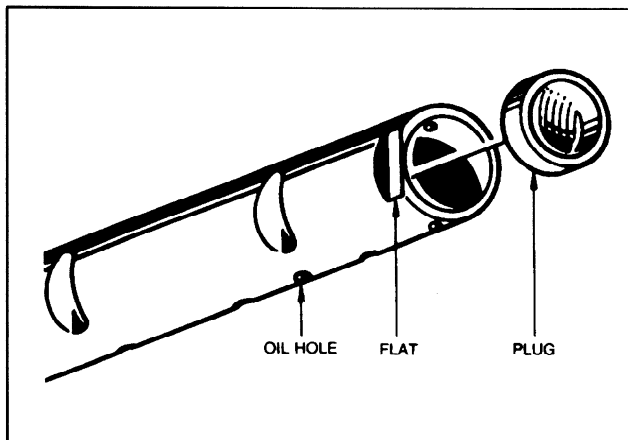

Installation

1. Refit new plugs to the rocker shaft ends.
2. Assemble the rocker arm shaft. **The bolt hole in the rocker arm shaft support must be on the same side as the adjusting screw in the rocker arm. The oil holes must point downward and the flat on the shaft to the front of engine. The rocker arms are right and left handed, the rocker pads being inclined towards the support.** Install the cotter pins with the heads upwards and bend over the legs to secure.
3. Lubricate the valve stem tips, rocker arm pads and the push rod ends with Lubriplate or equivalent. Position the rocker shaft assembly on the cylinder head engaging the push rods with the adjusting screws. Install and tighten the bolts evenly to specifications.

4. Adjust the valve clearance to specifications.
5. Ensure that the mating surfaces on the cylinder head and rocker cover are free from all traces of the old gasket material.
6. Position the rocker cover and gasket on the cylinder head and secure with the attaching screws. Torque the screws to specifications.
7. Locate the spark plug leads in the rocker cover clip and reconnect them to their respective plugs.
8. Install the air cleaner.

Intake Manifold

Removal

1. Partially drain the cooling system.
2. Remove the air cleaner.
3. Disconnect the throttle rod from the carburetor throttle lever.
4. Disconnect the fuel line and the distributor vacuum line from the carburetor.
5. Disconnect the water outlet hose and the crankcase ventilation hose from the intake manifold.
6. Remove the attaching nut and bolts and remove the intake manifold.
7. Remove the gasket.
8. If a new manifold is to be installed, transfer all necessary components to the new manifold.

Installation

1. Apply a water resistant sealer to both sides of the gasket around the water port and position it on the cylinder head.
2. Install the intake manifold and tighten the nuts and bolts evenly to specifications.
3. Connect the water hose and the crankcase ventilation hose to the intake manifold.
4. Connect the distributor vacuum line and the fuel supply line to the carburetor.
5. Connect the throttle rod.
6. Install the air cleaner.
7. Refill the cooling system with the recommended coolant.

Exhaust Manifold

Removal

1. Remove the exhaust pipe retaining nuts and exhaust pipe.
2. Remove the eight exhaust manifold retaining nuts.
3. Remove the exhaust manifold.
4. Remove the four exhaust gaskets and discard them.

REMOVAL AND INSTALLATION (Continued)

Installation

1. Install four new exhaust manifold gaskets onto the studs.
2. Install the exhaust manifold and torque the nuts to specification in the sequence shown.
3. Install the exhaust pipe and torque the retaining nuts to specification.

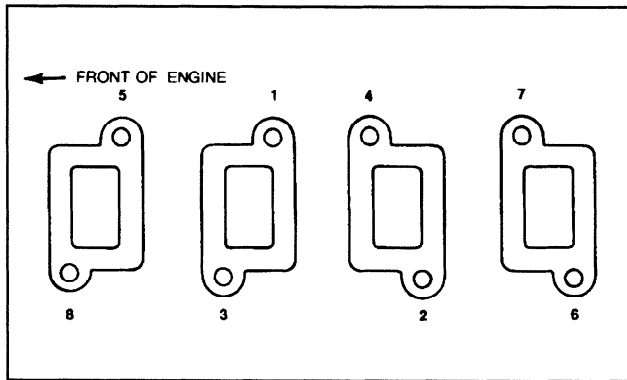

Cylinder Head

Removal

1. Remove the air cleaner.
2. Disconnect the fuel line at the fuel pump and carburetor.
3. Drain the coolant.
4. Disconnect the spark plug leads, remove them from the clip on the rocker cover and position out of the way.
5. Disconnect the water outlet and crankcase ventilation hoses at the intake manifold.
6. Disconnect the wire from the temperature gauge sending unit.
7. Detach the exhaust pipe.
8. Disconnect the throttle rod, choke cable and the distributor vacuum advance hose from the carburetor.
9. Disconnect the throttle linkage at the governor and position out of the way.
10. Remove the governor mounting bolts and remove governor.
11. Remove the thermostat housing, pull to one side and remove the thermostat.
12. Remove the rocker arm cover and gasket.
13. Remove the rocker arm shaft bolts evenly and lift off the rocker arm shaft assembly.
14. Lift out the push rods from their locations and keep them in their correct order.
15. Remove the cylinder head bolts and lift off the cylinder head and gasket. **Do not lay the cylinder head flat on its face as damage to the spark plugs or gasket surface can occur.**

Installation

1. Clean all gasket material from the mating surfaces and position the cylinder head gasket on the cylinder block using pilot studs.
2. Position the cylinder head, remove pilot studs and install the cylinder head bolts. Tighten the bolts down evenly in sequence and in four steps to specifications.

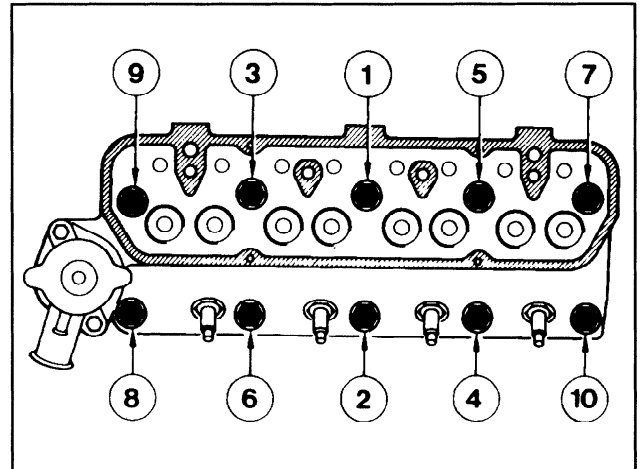

3. Lubricate both ends of the push rods with Lubriplate or equivalent and install them in their respective bores.
4. Install the rocker arm shaft assembly to the cylinder head, locating the push rods on the adjusting screws. Tighten the bolts evenly to specifications.
5. Adjust the valve clearances.
6. Install the rocker arm cover.
7. Connect the exhaust pipe.
8. Connect the distributor vacuum advance line, the throttle rod, and choke cable to the carburetor.
9. Connect the wire to the temperature gauge sender unit.
10. Connect the water outlet and crankcase ventilation hoses to the intake manifold.
11. Locate the thermostat in its bore in the cylinder head and install the gasket and thermostat housing.
12. Refill the cooling system.
13. Position governor and mounting bracket to cylinder head and install bolts.
14. Loosen governor adjusting bolts and position drive belt to governor. Adjust belt to specification and tighten bolts.
15. Connect the throttle linkage to the governor.
16. Install the alternator bracket mounting bolt to cylinder head.
17. Connect the ignition wires to the spark plugs in the correct firing order.
18. Install the air cleaner to the carburetor.
19. Adjust the carburetor idle speed and mixture settings.
20. Check governor operation, adjust as required.

REMOVAL AND INSTALLATION (Continued)

Valve Spring, Retainer and Stem Seal

Cylinder Head Removed

Removal

1. Remove the exhaust manifold and the spark plugs.
2. Compress the valve spring with a valve spring compressor. Remove the valve spring retainer locks, release the spring and remove the spring and retainer.
3. Remove the seal and withdraw the valve.

Installation

Lubricate all valves, valve stems and valve guides with heavy engine oil, SAE 50 weight.

1. Install each valve in the valve guide hole from which it was removed or to which a new valve is to be used.
2. Cover the valve grooves with plastic tape, slide the new seal onto the valve stem, remove the tape.

NOTE: The exhaust valves are fitted with umbrella type seals. The intake valves have the "positive" guide mounted seals which must be pressed on with a special service tool. "Positive" type seals may only be installed on intake valves not having the Ford oval on the stem.

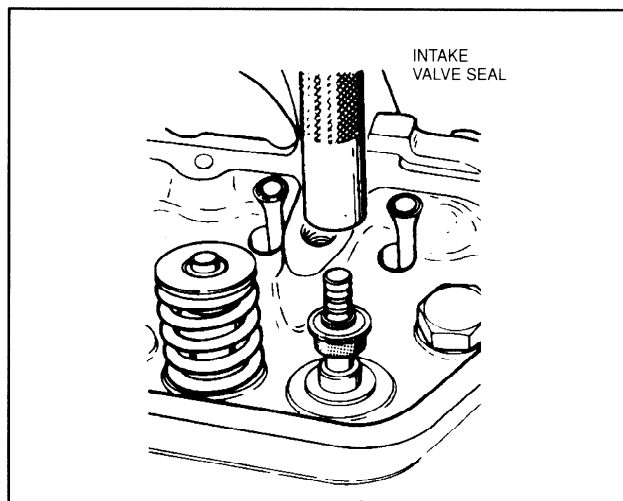

Cylinder Head Installed

Removal

1. Remove the air cleaner.
2. Disconnect the spark plug leads, remove them from the clip on the rocker cover and position out of the way.
3. Remove the rocker arm cover and gasket.
4. Remove the rocker arm shaft bolts evenly and lift off the rocker arm shaft assembly.
5. Lift the push rods from their locations and keep them in their correct order.
6. Remove the spark plugs.
7. Suitably support the appropriate valve with air pressure.
8. Compress the valve spring, using special service tool. Remove the valve spring retainer locks. Release the spring compressor, remove the valve spring retainer and the valve stem oil seal.

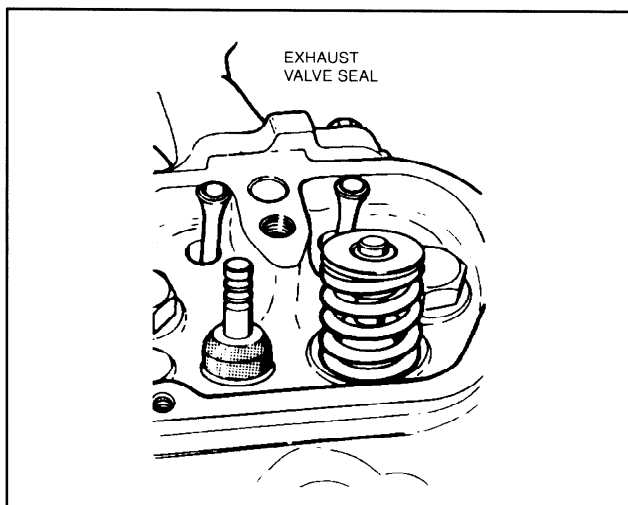

3. Install valve spring and damper assembly over the valve, then install spring retainer. Compress spring and install retainer key locks.
4. Measure the assembled height of the valve spring from the underside of the spring to the underside of the spring retainer. If the assembled height is not within specification, valve spring load loss may be excessive. Shim spring to specification.

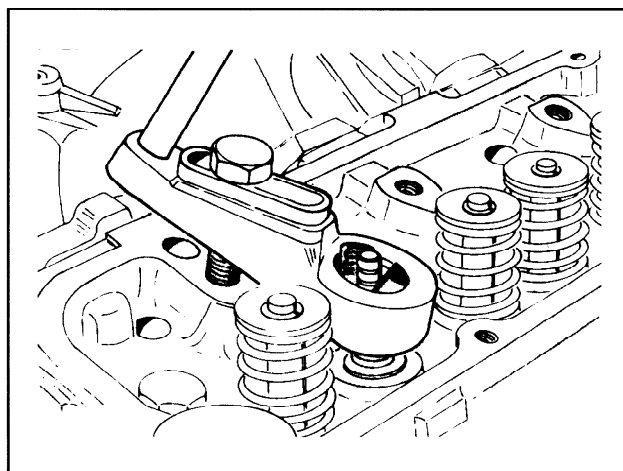

REMOVAL AND INSTALLATION (Continued)

Installation

- Cover the valve grooves with plastic tape, slide the new seal onto the valve stem, remove the tape.
NOTE: The exhaust valves are fitted with umbrella type seals. The intake valves have the "positive" guide mounted seals which must be pressed on with a special service tool.
- Position the valve spring and retainer over the valve stem.
- Compress the valve spring using the special service tool. Position the valve spring retainer locks in the valve stem grooves and slowly release the spring to engage the locks in the retainer. Remove the air hose and adapter.
- Lubricate both ends of the push rods with Lubriplate or equivalent and install them in their respective bores. Install the rocker arm shaft assembly to the cylinder head, locating the push rods on the adjusting screws. Tighten the bolts evenly to specifications.
- Adjust valve clearances to specification.
- Install the rocker cover with a new gasket and torque the attaching screws to specification.
- Install the spark plugs.
- Locate the spark plug leads in the rocker cover clip and reconnect them to their respective plugs.
- Install the air cleaner assembly.

Water Pump

Removal

- Drain the cooling system.
- Loosen the governor adjusting bolts and remove drive belt.
- Loosen the alternator adjusting and mounting bolts. Pivot the alternator towards the engine and remove the drive belt.
- Remove the fan and pulley attaching bolts. Remove the fan and pulley.
- Loosen the clamps and remove the lower hose from the water pump.
- Remove bolts securing water pump to cylinder block and remove the pump and gasket.

Installation

- Make sure that the mating faces of cylinder block and pump are clean.
- Position the pump and gasket on the cylinder block and secure with the attaching bolts.
- Position lower hose on water pump and tighten the clamp.
- Position the pulley and fan and secure with bolts. Torque the bolts to specification.

- Position drive belt over crankshaft, fan and alternator pulley and adjust the belt tension to specifications using Tool No. T63L-8620-A. Tighten the alternator mounting and adjusting bolt to specifications.
- Position the governor drive belt to governor and fan pulley. Adjust the belt to specification. Tighten adjusting bolts.
- Refill radiator and install cap. Start the engine and check for leaks.

Cylinder Front Cover and Timing Chain, or Crankshaft Sprockets

Removal

- Drain the engine coolant by opening the drain cock on the radiator and removing the drain plug in the cylinder block.
- Disconnect the radiator hoses at the engine.
- Remove the radiator.
- Remove the governor and fan belts and then remove the fan and the water pump pulley.
- Remove the water pump.
- Remove the crankshaft pulley.
- Remove the oil pan to cylinder front cover and front cover to block attaching bolts. Use a thin knife to cut the oil pan gasket flush with cylinder block face prior to separating the cover from the cylinder block. Remove the front cover.
- Remove the crankshaft oil slinger. Remove the camshaft sprocket retainer and bolts.
- Remove the timing chain tensioner arm. Remove the camshaft sprocket, and disconnect the timing chain.
- If crankshaft sprocket is to be removed, use a standard two-jaw puller.

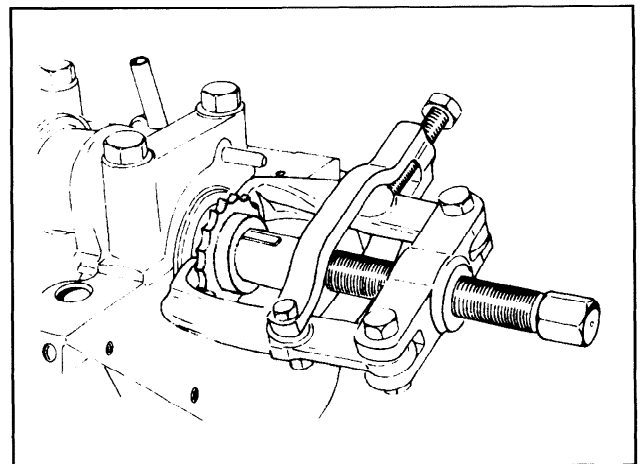

REMOVAL AND INSTALLATION (Continued)

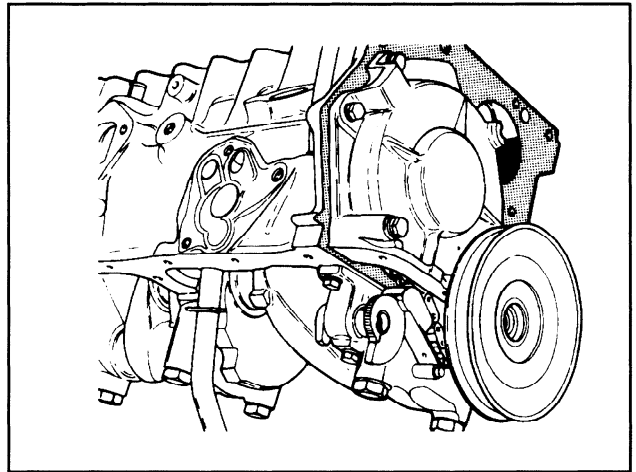
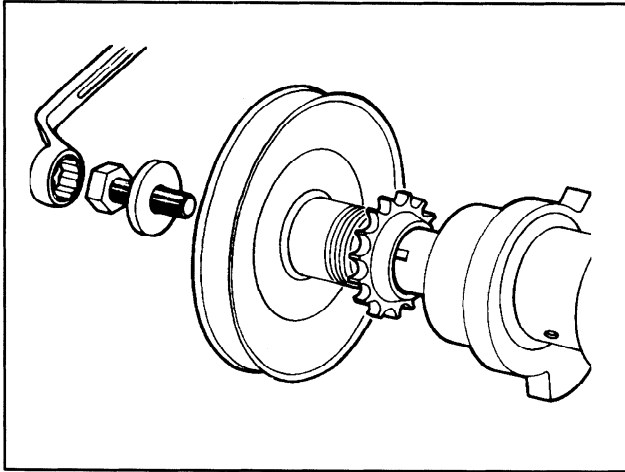

Installation

1. If crankshaft sprocket was removed, install using the pulley, bolt and washer. The timing mark on the sprocket must face the end of the crankshaft.
2. Position the timing chain over the camshaft and crankshaft sprockets so that the timing marks are aligned when the sprocket is installed. **The number 4 cylinder is on top dead center when using the gear marks as reference.** Tighten the bolts to specification, then bend up the locking tabs.

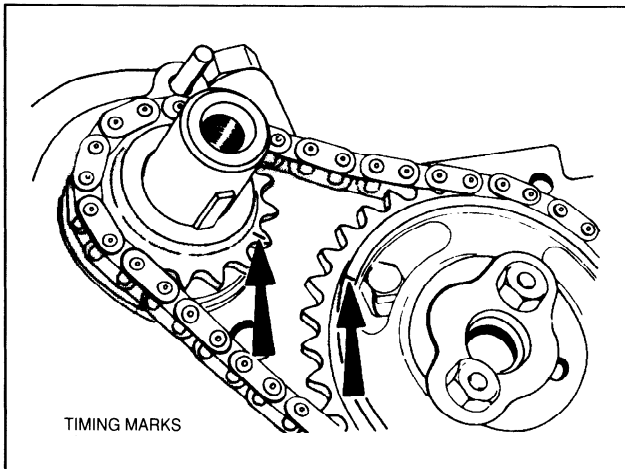

3. Locate the tensioner arm on the pivot pin while holding the tensioner cam in the released position.
4. Install the oil slinger on the crankshaft.
5. Position the gasket, portions of oil pan gasket, if necessary, and the end seal on the front cover with an oil resistant sealer at the ends. Install the front cover and align the seal by installing the crankshaft pulley. Tighten the attaching bolts evenly to specification.

6. Install and torque crankshaft pulley retaining bolt.
7. Install the water pump and torque the attaching bolts to specification.
8. Install the water pump pulley and fan. Install the governor and fan belts and adjust the tension of the belts to specifications using Tool T63L-8620-A.
9. Install the radiator.
10. Install the radiator upper and lower hoses and tighten the clamps.
11. Refill the radiator.
12. Start engine and check for oil and water leaks.

Adjusting Valve Clearances

1. **Only** turn the crankshaft belt pulley **clockwise** while adjusting the valve clearances and start by aligning the mark on the belt pulley with the "O" mark on the front cover.
2. If belt pulley is now turned to and fro slightly, valves of cylinder No. 1 or 4 will be rocking, i.e., the two rockers and push rods move in opposite directions.
3. When valves in cylinder No. 4 are rocking, No. 1 cylinder valve clearances should be adjusted.
4. Then rotate belt pulley a further half turn. In this position valves of cylinder No. 3 will rock and valve clearances of cylinder No. 2 can be adjusted and so on according to firing order. (See Technical Data for settings.)

Cylinder No. 4 rocking — adjust cylinder No. 1
 Cylinder No. 3 rocking — adjust cylinder No. 2
 Cylinder No. 1 rocking — adjust cylinder No. 4
 Cylinder No. 2 rocking — adjust cylinder No. 3

REMOVAL AND INSTALLATION (Continued)

Crankshaft Front Oil Seal

Removal

1. Loosen alternator and adjusting bracket bolts and remove fan belt.
2. Remove crankshaft pulley bolt and remove pulley by hand.
3. Remove oil seal from front cover using special service tool (21-096).

NOTE: Use short end of tool on this seal.

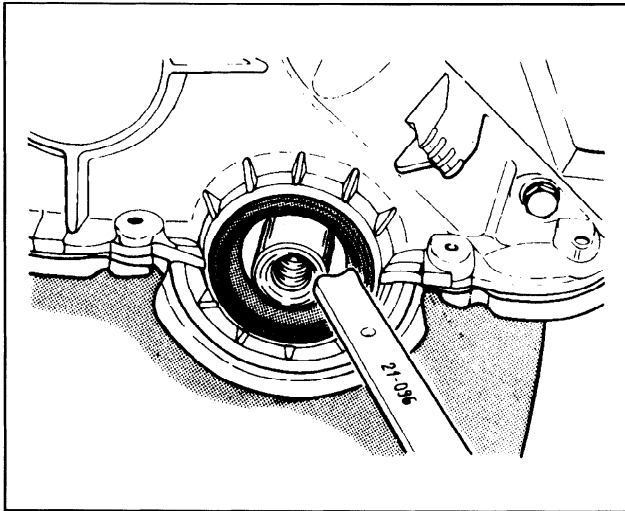

Installation

1. Lubricate the sealing lip of the new seal with engine oil and push new seal into front cover using tool 21-046, crankshaft pulley, bolt and washer.
2. Remove special service tool and reinstall crankshaft pulley. Torque bolt to specification.
3. Install fan belt and adjust the tension of the belts to specification using Tool T63L-8620-A. Tighten alternator and adjusting bracket bolts.

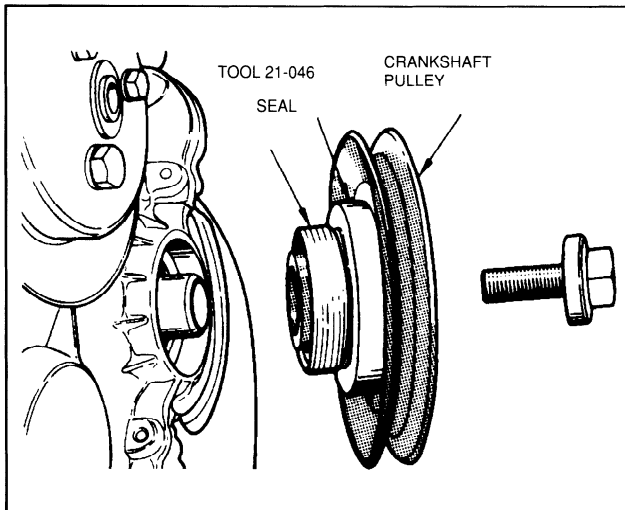

Camshaft and/or Valve Lifters

Removal

1. Remove the engine assembly and mount the engine on a stand. Drain the crankcase.
2. Disconnect the fuel line at the fuel pump.
3. Loosen the generator and governor adjustment bolts and remove the belts.
4. Remove the fan and water pump pulley.
5. Remove the oil and fuel pumps from the cylinder block.
6. Disconnect the spark plug wires from the plugs.
7. Remove the rocker arm cover attaching screws and rocker cover. Clean all gasket material from rocker arm cover and cylinder head.
8. Remove the rocker arm shaft support bolts evenly and lift off the rocker arm shaft.
9. Lift the push rods from their locations in the cylinder block, taking care to keep them in their correct order.
10. Invert the engine on the stand and remove the oil pan and gaskets.
11. Remove the crankshaft pulley, the front cover and oil slinger.
12. Remove the timing chain tensioner assembly.
13. Remove the camshaft sprocket and timing chain.
14. With the engine inverted, remove the camshaft thrust plate and remove the camshaft.
15. If necessary, remove the tappets from their locations in the cylinder block and keep them in the correct order.

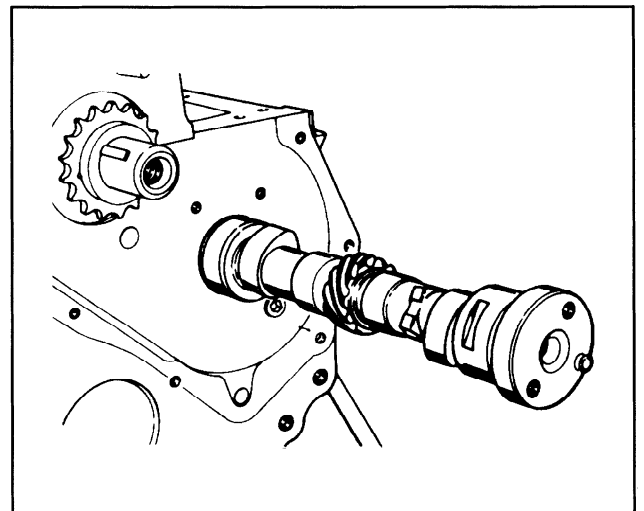

Installation

1. Install a new front cover oil seal, using Tool 21-046.
2. Install the tappets, if removed.
3. Install the camshaft and fit the thrust plate in the camshaft groove. Tighten the attaching bolts to specification and bend up the locking tabs.

REMOVAL AND INSTALLATION (Continued)

4. Check the camshaft end play.
5. Locate the timing chain on the camshaft sprocket and install the camshaft sprocket with the timing mark aligned with the one on the crankshaft sprocket. Tighten the attaching bolts to specification and bend up the locking tabs.
6. Locate the tensioner arm on the pivot pin and install the timing chain tensioner.
7. Install the oil slinger on the crankshaft.
8. Position the gasket on the front cover with an oil resistant sealer at the ends, align the front cover with the crankshaft pulley and tighten the bolts evenly to specification.
9. Position a new gasket on the block flange using an oil resistant sealer compound at each end. Position the end seals chamfered ends into the groove, again using an oil resistant sealer at the ends and install the oil pan. Tighten the oil pan bolts to the correct torque, **FOLLOWING FIRST THE ALPHABETICAL, THEN THE NUMERICAL SEQUENCES SHOWN.**

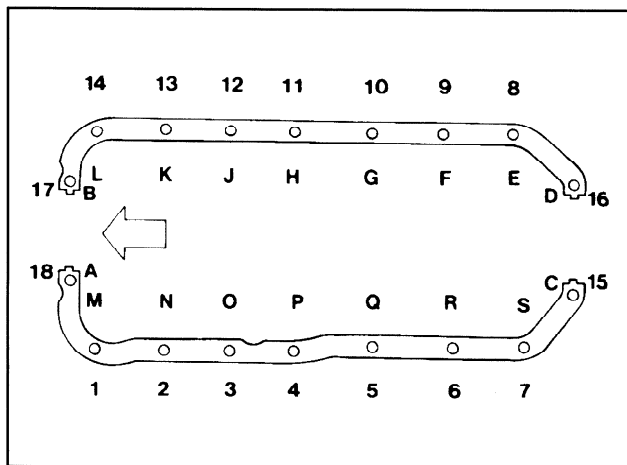

10. Install the dipstick.
11. Install the crankshaft pulley aligning the pulley slot with the crankshaft key. Tighten the pulley attaching bolt to specification.
12. Right the engine on stand.
13. Position a new gasket on the oil pump mounting flange and install the oil pump and filter assembly. Tighten the attaching bolts to specification.
14. Position a new gasket to the fuel pump flange and insert the rocker arm through the slot in the block wall so that the arm lies on the camshaft eccentric. Secure the fuel pump to the cylinder block with two washers and bolts, tightening the bolts evenly to specifications.

15. Lubricate push rod ends, valve stem tips and rocker pads with Lubriplate or equivalent. Install the push rods in their respective bores and install the rocker arm shaft assembly, making sure that the cupped ends of the push rods engage the adjusting screws. Tighten the rocker arm shaft attaching bolts evenly to specification.
16. Adjust the valve clearances to specification.
17. Install the rocker arm cover and a new gasket and secure with attaching screws and torque to specifications.
18. Connect the vacuum advance line to the carburetor.
19. Connect wires to spark plugs.
20. Install the water pump pulley and fan. Position the generator and governor drive belts on the pulley and adjust the belt tension to specifications. Connect the fuel line from the carburetor to the fuel pump.
21. Remove engine from stand.
22. Install the engine assembly in the unit.
23. Start the engine and check for oil and water leaks.
24. Install the air cleaner assembly.
25. Start engine, adjust the ignition timing, if necessary.
26. Adjust the carburetor idle speed and fuel-air mixture to specifications. Check governor operation.

Camshaft Bearings

The service bearings for the camshaft are pre-sized and require no machining after installation. When one bearing requires replacement it is advisable to replace all three, as camshaft alignment may be affected if only one bearing is changed.

The camshaft front and rear bearing are both approximately 19 mm (3/4 inch) wide, the front one having an additional oil hole for the rocker arm shaft oil feed, and the center bearing approximately 16 mm (5/8 inch) wide. Install the bearings using a replacer in addition to the adapters previously used. Make sure that the oil holes in the bearings and cylinder block are correctly aligned before installation and that the splits in the bearings are upwards and outwards at 45 degrees to the vertical.

Removal

Remove camshaft following the appropriate procedures in this section.

1. Remove the flywheel.
2. Remove the crankshaft rear oil seal carrier.
3. Remove the camshaft bearings.
4. Check all the oil passages to make sure that they are clear. Apply an oil resistant sealer to the oil gallery plugs prior to installation.

REMOVAL AND INSTALLATION (Continued)

Installation

1. Install new camshaft bearings. Make sure that the oil holes in the bearings and cylinder block are aligned. The splits in the bearings should be upwards and outwards at 45 degrees to the vertical.

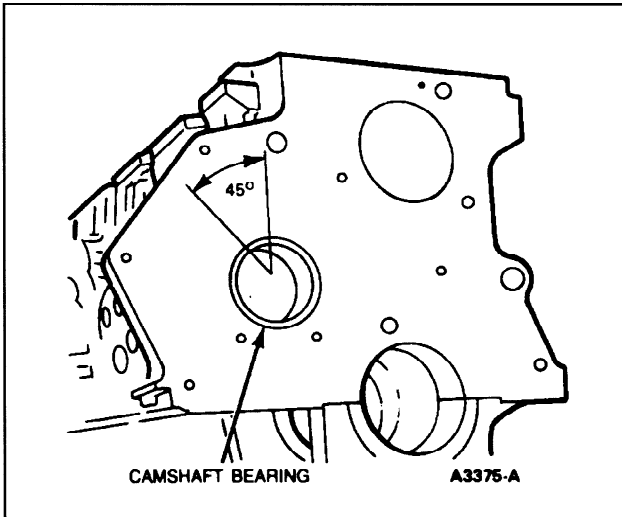

2. Install a new crankshaft rear oil seal using Tool 21-059A.
3. Position a new gasket to the rear oil seal carrier using an oil resistant sealer at the ends. Install the carrier on the cylinder block and tighten the bolts evenly to specification.
4. Locate the flywheel squarely on the crankshaft flange. Tighten the attaching bolts to specification.
5. Install the camshaft and related parts following the appropriate procedures in this section.

Oil Pump

The oil pump and filter assembly is bolted to the right side of the cylinder block and can be removed with the engine in place.

Removal

1. Place a drain pan under the oil pump.
2. Remove the oil filter from the oil pump.
3. Remove the three bolts attaching the oil pump and remove the assembly.

Installation

1. Ensure the mating surfaces are clean of old gasket material, then install the oil pump assembly on the cylinder block, using a new gasket together with an oil resistant sealer and secure with the three bolts. Tighten the bolts to specifications.
2. Install the oil filter to the oil pump assembly.
3. Check the oil level and add oil if necessary.
4. Start the engine and check for oil leaks.

Oil Pan

Removal

1. Drain the crankcase.
2. Remove the oil level dipstick.
3. Remove the three bolts and remove the starter motor.
4. Remove the oil pan attaching bolts and remove the pan and gasket.

Installation

1. Clean the oil pump inlet tube and screen assembly.
2. Clean the gasket surfaces of the block and oil pan. Be sure to clean the seal retainer grooves in the cylinder front cover and the rear seal retainer. The oil pan has a two-piece gasket. Coat the block surface and the oil pan gasket surface with oil-resistant sealer. Position the oil pan gaskets on the cylinder block.
3. Position the end seals with the chamfered ends into the grooves, again using an oil resistant sealer. Position the oil pan and tighten the bolts evenly to specifications following first the alphabetical, then the numerical sequences shown.

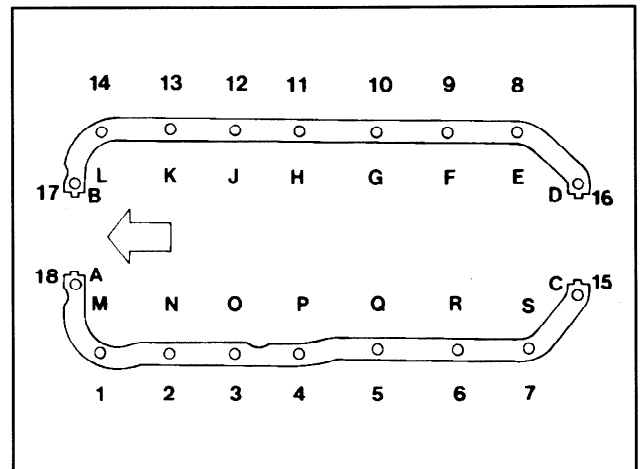

4. Clean and install the starter motor, securing it with the three bolts.
5. Refill the oil pan with the correct grade of engine oil and install the dipstick.
6. Start the engine and check for oil leaks.

Flywheel Ring Gear

The flywheel ring gear is located in a retention groove and can be removed by cutting between two adjacent teeth with a hacksaw and splitting the gear with a chisel. In no circumstances should pressure be applied in an attempt to remove the ring gear for repositioning on the flywheel.

REMOVAL AND INSTALLATION (Continued)

When installing the ring gear it must be heated evenly to a temperature of 260 to 280°C (500-535°F). Do not exceed 290°C (554°F) as the ring gear wear resistant properties will be destroyed. If the ring gear is to be heated by direct flame, place the ring gear on a metal plate approximately 2 to 3 mm (.079-.118 in.) thick and heat plate from below in the area of the ring gear until it reaches the required temperature. The correct temperature can be detected by using a special type of temperature sensitive crayon. Fit the ring gear with the chamfers on the leading faces of the gear teeth relative to the direction of rotation. Allow the ring gear to cool naturally in air. **Do not quench.**

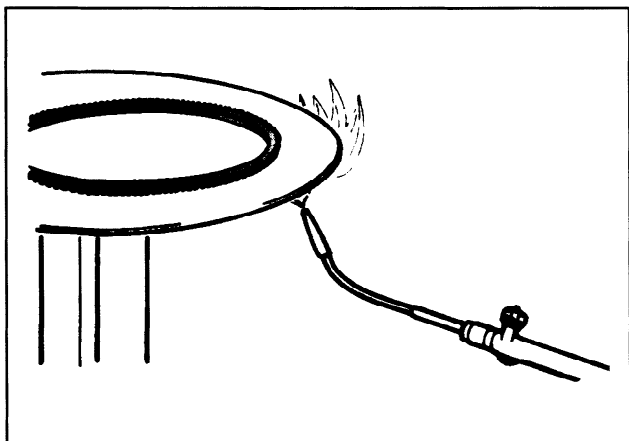

Crankshaft Rear Oil Seal

Removal

1. Remove the P.T.O. or transmission clutch & pressure plate.
2. Remove the flywheel.
3. Remove the rear oil seal using tool 21-096.

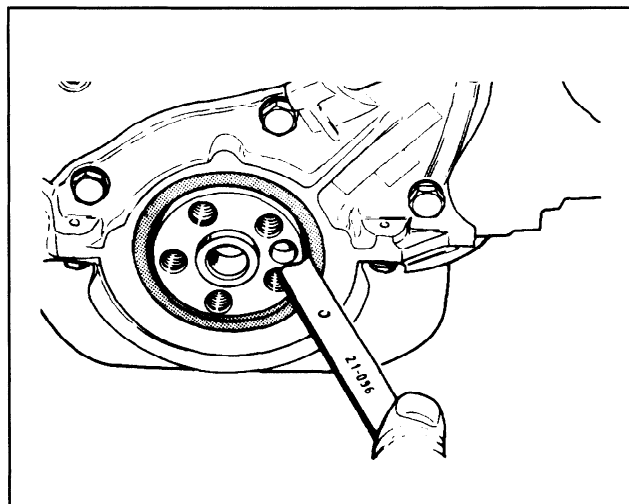

Installation

1. Lubricate the sealing lip of the new seal with engine oil and push new seal into seal carrier using tool 21-059A.
2. Locate the flywheel squarely on the crankshaft flange. Tighten the bolts evenly to specification.
3. Install the P.T.O. or transmission, clutch and pressure plate.

Pistons and Connecting Rods

Removal

1. Drain the cooling system and the crankcase.
2. Refer to Cylinder Head Removal in this Section and remove the cylinder head and related parts.
3. Remove the oil pan following the procedure under Oil Pan Removal in this Section.
4. Turn the crankshaft until the piston to be removed is at the bottom of the stroke and place a cloth on the piston dome to collect the cuttings. Remove any ridge and/or deposits from the upper end of the cylinder bore with a ridge cutter. Follow the instructions furnished by the tool manufacturer. **Never cut into the ring travel area in excess of 0.8 mm (1/32 inch) when removing ridges.**
5. Make sure all the connecting rod caps are marked so that they can be installed in their original positions. Remove the connecting rod cap.
6. Push the connecting rod and piston assembly out the top of the cylinder with the handle end of a hammer. Avoid damage to the crankshaft journal or the cylinder wall when removing the piston and rod.

Installation

1. Refer to Cylinder Block — Refinishing in this Section.
2. Oil the piston rings, pistons and cylinder walls with light engine oil.
3. **Be sure to install the pistons in the same cylinders from which they were removed or to which they were fitted.** The connecting rods and bearing caps are numbered from 1 to 4 beginning at the front of the engine. The number on the connecting rod and bearing cap must be on the same side of rod when installing in the cylinder bore. If a connecting rod is ever transferred from one cylinder block to another or from one cylinder to another, new bearings should be fitted and the connecting rod should be re-numbered to correspond with the new cylinder number.
4. Make sure the ring gaps are properly spaced around the circumference of the piston. Oil the rings, then install a piston ring compressor on the piston. Make sure that the arrow in the dome of piston is toward the front, then push the piston into its bore with the handle end of a hammer until it is slightly below the top of the cylinder. Be sure to guide the connecting rods to avoid damaging the crankshaft journals.

REMOVAL AND INSTALLATION (Continued)

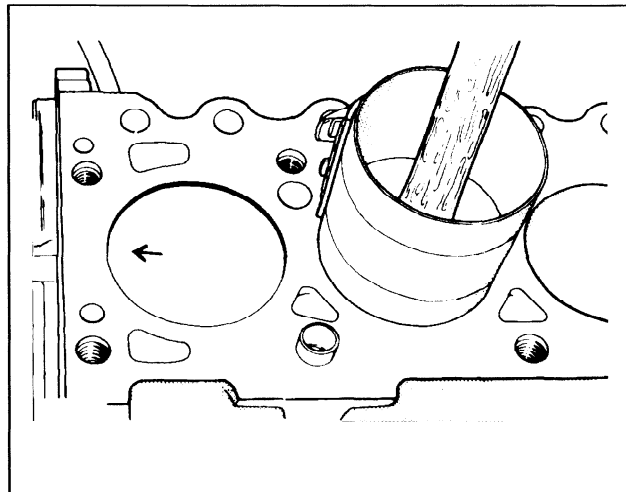
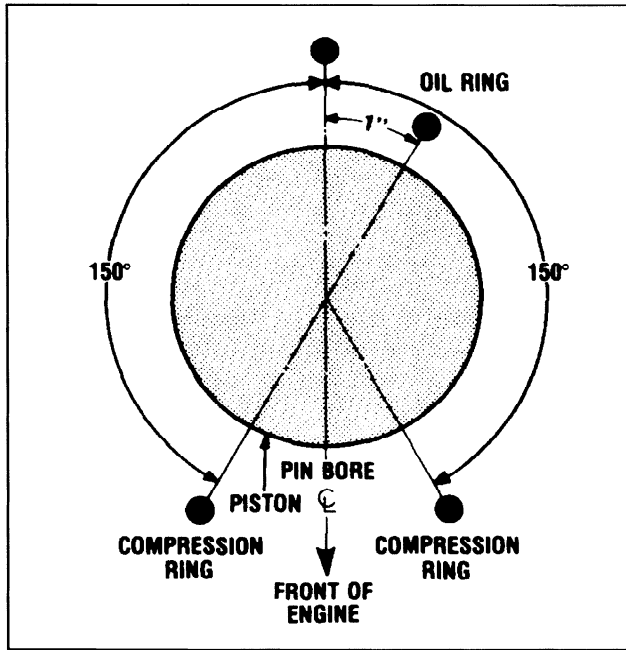

5. Check the clearance of each bearing following the procedure under Overhaul in this section.
6. After the bearings have been fitted, apply a light coat of engine oil to the journals and bearings.
7. Turn the crankshaft throw to the bottom of its stroke, then push the piston all the way down until the connecting rod bearing seats on the crankshaft journal. Install the connecting rod cap. Tighten the nuts to specification.
8. After the piston and connecting rod assemblies have been installed, check the connecting rod side clearance on each crankshaft journal.
9. Install the oil pan and related parts. Follow procedures in this Section.
10. Refer to Cylinder Head Installation and install the cylinder head and related parts. Adjust the valve clearance as described in this Section.
11. Fill and bleed the cooling system. Fill the crankcase.
12. Start the engine and check for oil pressure. Operate the engine at fast idle and check for oil and coolant leaks.
13. Operate the engine until engine temperatures have stabilized. Check and adjust the ignition timing. Adjust the engine idle speed and fuel mixture to the specifications.

Oil Filter

Removal

Place a drip pan under the filter. Unscrew the filter from the adapter fitting. Clean the adapter filter recess.

Installation

1. Coat the gasket on the replacement filter with oil. Position the filter on the adapter fitting. Hand tighten the filter until the gasket contacts the adapter face, then advance it 1/2 turn.
2. Operate the engine at fast idle, and check for oil leaks. If oil leaks are evident, perform the necessary repairs to correct the leakage. Check the oil level and fill the crankcase as required.

DISASSEMBLY AND ASSEMBLY

Engine Assembly

Disassembly

1. Mount the engine on a stand and drain crankcase.
2. Disconnect the fuel line at the fuel pump and carburetor.
3. Disconnect the spark plug leads, remove them from the clip on the rocker cover and position out of the way.
4. Disconnect the water outlet and crankcase ventilation hoses at the intake manifold.
5. Disconnect the wire from the temperature gauge sending unit.
6. Disconnect the throttle rod from the carburetor.
7. Remove the governor mounting bolts and remove governor and drive belt.
8. Remove the thermostat housing and thermostat.
9. Remove the rocker arm cover and gasket.
10. Remove the rocker arm shaft bolts evenly and lift off the rocker arm, shaft assembly.
11. Lift out the push rods from their locations and keep them in their correct order.
12. Remove the cylinder head bolts and lift off the cylinder head and gasket. Do not lay the cylinder head flat on its face as damage to the spark plugs or gasket surface can occur.
13. Remove the fuel pump and oil pump.
14. Remove the dipstick and tube.
15. Remove the secondary wiring.
16. Remove fan, spacer, pulley and generator belt.
17. Remove the generator mounting and adjusting bracket bolts. Remove generator.
18. Remove crankshaft pulley.
19. Remove the water pump, front cover and crankshaft oil slinger.
20. Remove any ridge and/or carbon deposits from the upper end of the cylinder bores. Move the piston to the bottom of its travel and place a cloth on the piston head to collect the cuttings. Remove the cylinder ridge with a ridge cutter. Follow the instructions furnished by the tool manufacturer. **Never cut into the ring travel area in excess of 0.8 mm (1/32 inch) when removing ridge.**
21. Invert the engine on the stand and remove the oil pan and gaskets.
22. Remove the oil pick up tube and screen.
23. Remove the flywheel and tear engine plate.
24. Remove the tear bearing retainer.
25. Remove the timing chain tensioner.
26. Remove the camshaft sprocket and timing chain.

27. Remove the camshaft thrush plate and the camshaft.
28. Remove the tappets keeping them in their correct order.
29. Make sure all connecting rods and caps are marked so that they can be installed in their original locations. Partially loosen the connecting rod bolts several turns and tap them to release the bearing caps. Remove the bolts completely and remove the caps. Push the pistons out of the bores and remove the assemblies.
30. Remove the main bearing caps bolts evenly and lift off each cap. Lift out the crankshaft and handle with care to avoid possible fracture or damage to finished surfaces.
31. Remove the main bearings from block and cap. Remove the thrust washers.
32. Disassemble the piston and connecting rod assemblies. Remove the piston rings and the two piston pin snap rings. Push the piston pin out of each piston.
33. Remove the coolant drain plug and oil pressure sending unit from the block.
34. Remove the block from the stand.

Assembly

When installing nuts or bolts that must be tightened (refer to the torque specifications), oil the threads with light weight engine oil. **Do not oil threads that require oil-resistant or water-resistant sealer.**

Start the assembly by examining the block and crankshaft to determine the bearings to be used. The block with standard main bearing bores is unmarked. With 0.38 mm (0.015 inch) oversized main bearing bores, the bearing caps are marked with white paint.

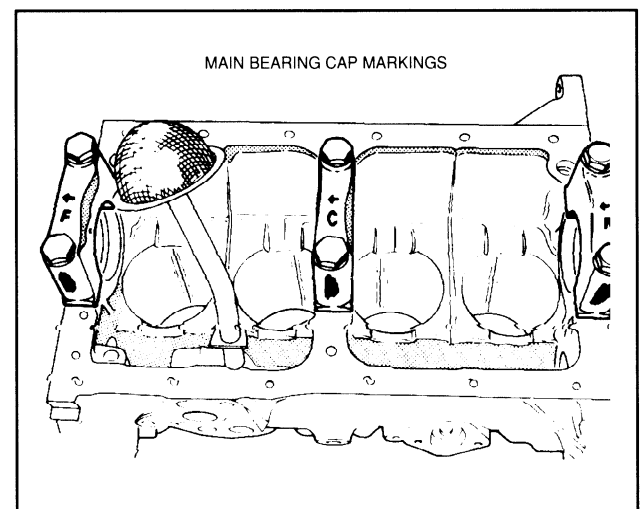

DISASSEMBLY AND ASSEMBLY (Continued)

The crankshaft main bearing journals of standard diameter came in two size categories and are either unmarked or have a yellow paint mark on the first counterweight. See specifications for dimensions.

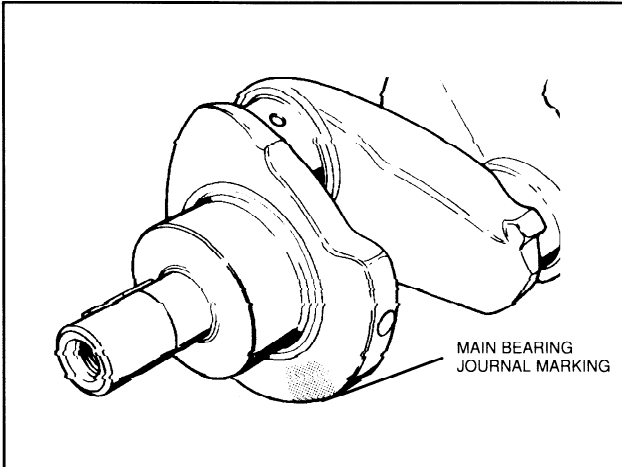

The standard diameter connecting rod journals are unmarked. Where the connecting rod journals are 0.25 mm (.010 inch) undersize, the crankshaft is marked with a green paint spot on the web next to the connecting rod bearing journal number one, as shown.

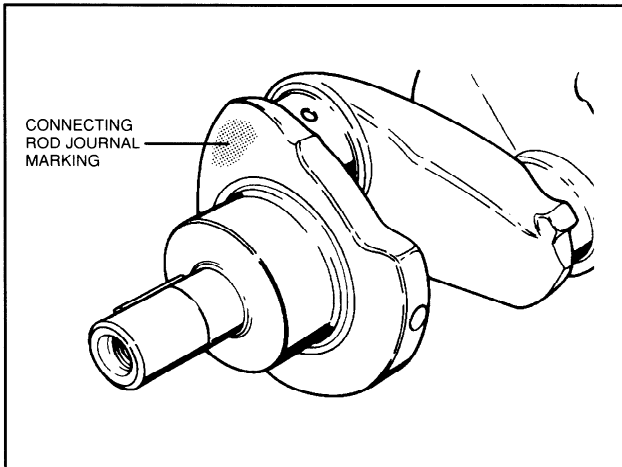

The standard main bearing and connecting rod bearing inserts have no color marking. Bearing inserts for undersize (u/s) crankshafts or oversize (o/s) cylinder blocks have corresponding inscriptions on the back.

When new bearing inserts are selected they should be measured to ensure that they are the appropriate size. Be sure that the specified tolerances are adhered to by

measuring bearing journals and block bores individually with the bearing inserts installed.

1. Mount the block in the stand inverted.
2. Install the coolant drain plug and oil pressure sending unit.
3. Place the upper main bearing inserts in position in the bore with the tang fitting in the slot provided.
4. Install the lower main bearing inserts in the bearing caps.
5. Carefully lower the crankshaft into place. **Be careful not to damage the bearing surfaces.** Check the clearance of each main bearing following the procedures in the Overhaul Section.
6. Install the thrust washers to the center main. Apply a light coat of oil to the journals and bearings. Install the main bearing caps. Tighten the main bearing cap bolts evenly to specifications and check crankshaft rotation.
7. Check the crankshaft end play.
8. Install the tappets into their respective bores.
9. Oil the camshaft journals with heavy engine oil and apply Lubriplate or equivalent to all lobes and then carefully slide it through the bearings.
10. Position the camshaft thrust plate and tighten the attaching bolts to specifications. Check the camshaft end play. Bend the locking tabs to secure the bolts.
11. Install the camshaft sprocket and timing chain aligning the timing marks on the camshaft and crankshaft sprockets. Tighten the attaching bolts to specification and bend up the locking plate tabs.
12. Position the timing chain tensioner arm on the pivot pin and install the tensioner.

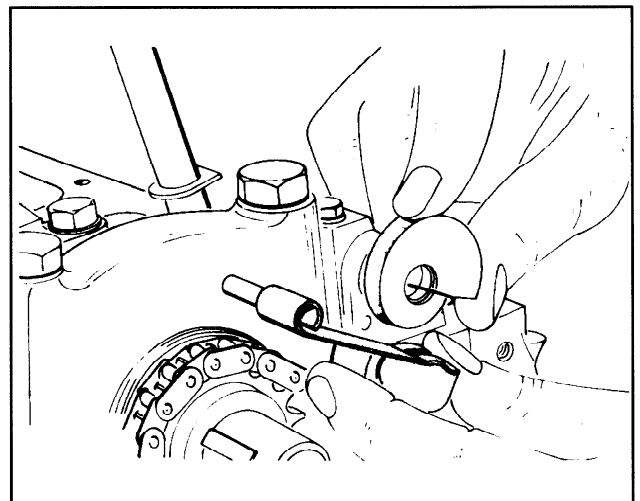

DISASSEMBLY AND ASSEMBLY (Continued)

13. Install a new oil seal to the front cover using tool 21-046.
14. Install the oil slinger on the crankshaft and position the front cover gasket in place using oil resistant sealer. Locate the front cover, aligning the seal to the crankshaft with pulley. Tighten the bolts evenly to specification.
15. Install a new oil seal in the rear oil seal carrier using tool 21-059A
16. Position a new gasket on the rear oil seal carrier using oil resistant sealer. Secure the carrier to the cylinder block. Tighten the bolts evenly to specification.
17. Assemble the respective pistons to their connecting rods. Be sure the "F" or "front" on the rod and the arrow on the top of the piston face the same side. Push the piston pin into the piston and rod and install the two piston pin snap rings on service pistons only.

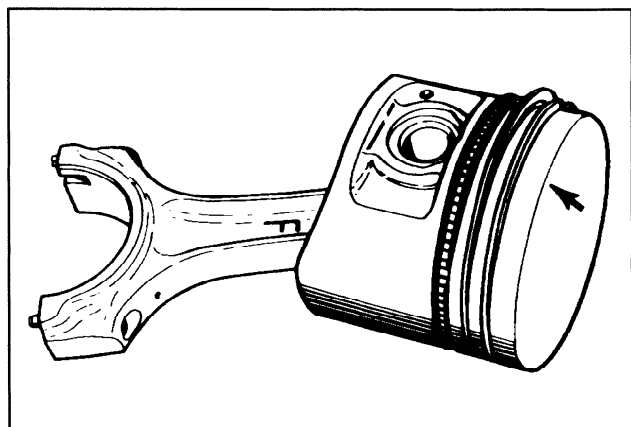

18. Install the rings on the piston starting with the oil ring, then the second compression ring and the top compression ring. Position the gaps as shown.

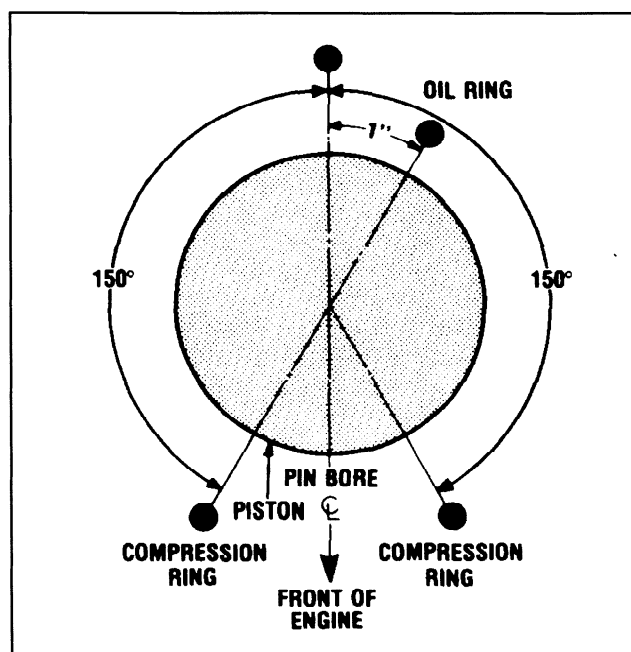

19. Rotate the engine in the stand so that the front end is up. Oil the piston rings and cylinder bores with engine oil. Compress the rings using a universal piston ring compressor. Install the piston and connecting rod assemblies into their respective bores with the arrow on top of the piston pointing toward the front of the block.
20. Install the connecting rod bearings and check the clearances as detailed in the Overhaul Section.
21. Oil the hearings and journals with engine oil and install the connecting rod bearing caps. Tighten the bolts to specification. Check the connecting rod side clearance.
22. Rotate the engine to the inverted position. Replace the oil pump pick up tube and screen. Press the tubes to the full depth of the counter bored holes.
23. Position the flywheel squarely on the crankshaft flange. Tighten the attaching bolts evenly to specification.
24. Install the crankshaft pulley and torque the bolt to specification.
25. Coat the block surface and the oil pan gasket surface with oil resistant sealer. Position the oil pan gaskets on the cylinder block. Position the end seals with the chamfered ends into the grooves, again using an oil resistant sealer at the mating areas. Position the oil pan and tighten the bolts evenly to specification following first the alphabetical, then the numerical sequences shown.

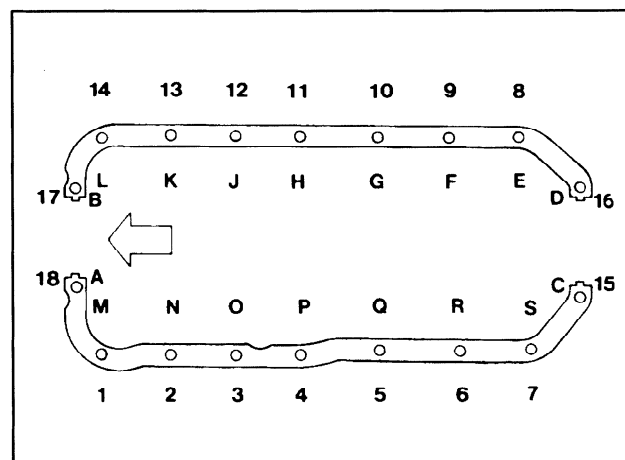

26. Right the engine in the stand. Position a new gasket on the water pump and install the pump on the block.
27. Position the generator and brackets to the block and install mounting bolts.
28. Position a new oil pump mounting gasket to the block using oil resistant sealer. Position the pump to the block, install the mounting bolts and torque to specifications.
29. Position a new gasket to the fuel pump flange and insert the rocker arm through the slot in the block so that the arm lies on the camshaft lobe. Install the mounting bolts and tighten evenly to specification.

DISASSEMBLY AND ASSEMBLY (Continued)

30. Position the cylinder head gasket on the cylinder block using pilot studs.
31. Position the cylinder head, remove the pilot studs and install the cylinder bolts. Tighten the bolts down evenly in sequence and in three steps to specification.

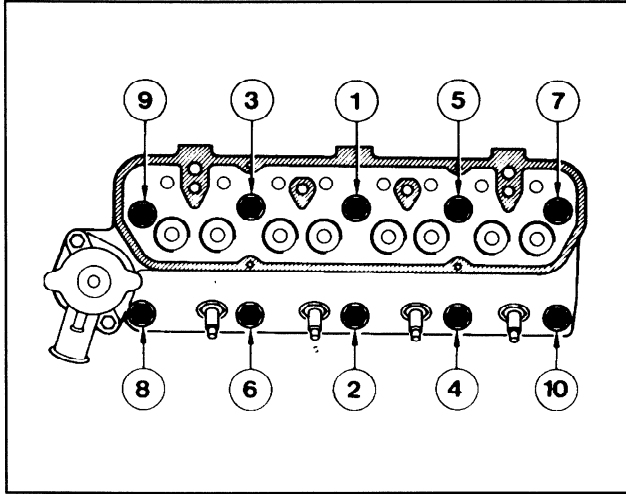

32. Lubricate both ends of the push rods with Lubriplate or equivalent and install them in their respective bores.
33. Install the rocker arm shaft assembly to the cylinder head, locating the push rods on the adjusting screws. Tighten the bolts evenly to specification. Adjust the valve clearances. Install the rocker cover.
34. Locate the thermostat in its bore in the cylinder head and install the gasket and thermostat housing. Connect the wire to the temperature gauge sending unit. Connect primary wires to coil.
35. Install dipstick and tube.
36. Position governor and install mounting bolts.
37. Connect the throttle rod to the carburetor.
38. Connect the water outlet and crankcase ventilation hoses at the intake manifold.
39. Connect the leads to the spark plugs.
40. Connect the fuel line at the fuel pump and carburetor.

41. Install remaining generator adjusting arm mounting bolts. Loosen generator and governor adjusting bolts.
42. Install water pump pulley, spacer and fan. Install generator and governor drive belts. Adjust both belts to specifications.
43. Remove engine from stand.

Oil Pump

Disassembly

1. Remove the filter.
2. Remove the end plate and withdraw the rubber O-ring from the groove in the pump body.
3. If it is necessary to replace the rotor assembly, remove the outer rotor, then drive out the retaining pin securing the gear to the shaft and pull off the gear.
4. Remove the inner rotor and shaft.
5. Drill a small hole and insert a self-threading sheet metal screw of the proper diameter into the oil pressure relief valve chamber cap and pull the cap out of the chamber. Remove the spring and plunger.

Assembly

1. Oil all parts thoroughly.
2. Install the oil pressure relief valve plunger, spring and new cap.
3. Install the inner rotor and shaft assembly in the pump body. Press the gear onto the shaft supporting the shaft at the rotor end on a suitable spacer, until the far end of the gear teeth are 57.2 mm (2-1/4 inches) from the mounting flange. If a new shaft and/or gear are used, drill a 3.2 mm (1/8 inch) hole at right angles to the shaft through the gear shoulder 33.3 mm (1-5/16 inches) from the mounting flange. Replace the gear retaining pin and peen over the ends securely.
4. Install the outer rotor with its chamfered side facing inward toward the pump body.
5. Place a new rubber O-ring in the groove in the pump body. Position the end plate with the machined face toward the rotors and install the retaining bolts.
6. Coat the gasket on the oil filter with engine oil. Position the filter to the pump housing. Hand tighten the filter until the gasket contacts the face, then advance it 1/2 turn.

SECTION TITLE	PAGE	SECTION TITLE	PAGE
BASIC ENGINE	01-1	STARTING SYSTEM	05-1
IGNITION SYSTEM – DISTRIBUTORLESS	02-1	GOVERNOR	06-1
FUEL SYSTEM	03-1	COOLING SYSTEM	07-1
EMISSION CONTROL SYSTEM	03A-1	SPECIFICATIONS	08-1
CHARGING SYSTEM	04-1		

SECTION 02 — Ignition System Distributorless

SUBJECT	PAGE	SUBJECT	PAGE
DESCRIPTION AND OPERATION	02-3	DIAGNOSING AND TESTING DIS	02-8
Engine Speed and C/S Position	02-3	DIS Diagnosis Equipment	02-8
Engine Load	02-4	DIS Diagnosing	02-8
Engine Temperature	02-4	DIS Cleaning and Inspection	02-8
Fuel Octane Level Adjustment	02-4	Spark Plugs	02-8
Ignition Coil Driver	02-4	Ignition Coil	02-8
Sensor Fail-Safe	02-4	Ignition Wires	02-8
Cranking Mode	02-4	Spark Plug Inspection Chart	02-9
Run Mode	02-4	DIS Engine Harness Checks	02-10
Transient Mode	02-4	Spark Timing	02-10
Overspeed Mode	02-4	Engine Coolant Temperature	
SERVICE ADJUSTMENTS AND CHECKS	02-5	Sensor Characteristics	02-10
REMOVAL AND INSTALLATION	02-6	Wiring Harness Circuit	
Ignition Coil	02-6	Identification – F4JL-14305-AA	02-12
Engine Speed Sensor	02-6	Wiring Harness Circuit	
Engine Coolant Temperature Sensor	02-7	Identification – F4JL-14305-BA	02-14

BLANK

DESCRIPTION AND OPERATION

WARNING

- **HIGH VOLTAGE PRODUCED BY A DISTRIBUTORLESS IGNITION SYSTEM IS HIGHER THAN FOR A CONVENTIONAL IGNITION SYSTEM.**
- **WHEN CARRYING OUT SERVICE OPERATIONS ON AN ENGINE EQUIPPED WITH DISTRIBUTORLESS IGNITION, IT IS IMPORTANT TO BE AWARE OF THE ABOVE POINT AS WELL AS ALL THE USUAL SAFETY MEASURES TO PREVENT THE POSSIBILITY OF ELECTRIC SHOCKS.**

The purpose of an engine's ignition system is to ignite the fuel/air mixture at the correct time and sequence based upon the input it receives.

The Distributorless Ignition System (DIS) used on the VSG 411/413 engines is a state-of-the-art ignition system. The brain of this system is the Ignition Control Module (ICM), also known as the Universal Electronic Spark Control (UESC) module. This module normally receives four inputs:

- Crankshaft position
- Crankshaft speed
- Engine temperature
- Engine vacuum (load)

From these inputs, the ICM computes spark strategy (spark advance) to obtain optimum engine performance for correct input conditions.

With this system, the electronic control module monitors the engine load, speed, and operating temperature and decides what degree of spark advance is correct for all of the operating conditions. This system maximizes the benefits of the high compression swirl design. Because timing is set for life inherently in the design of the engine, and there are no moving parts in the ignition system itself, no maintenance is required except for periodic spark-plug checks. The system provides for fixed spark advance at start-up, for cold weather starting, fixed advance for service checking, and for "average value" default settings in case of component failure. Particular attention has been given to spark optimization for excellent fuel economy in the warm-up mode, which is coupled with improved warm-up and a new carburetor.

The spark plugs are paired so that one plug fires during the compression stroke and its companion plug fires during the exhaust stroke. The next time that coil is fired, the plug that was on exhaust will be on compression, and the one that was on compression will be on exhaust. The spark in the exhaust cylinder is wasted but little of the coil energy is lost.

The spark strategy is based on sensors and manifold vacuum input to the ICM module, which include the following **inputs**:

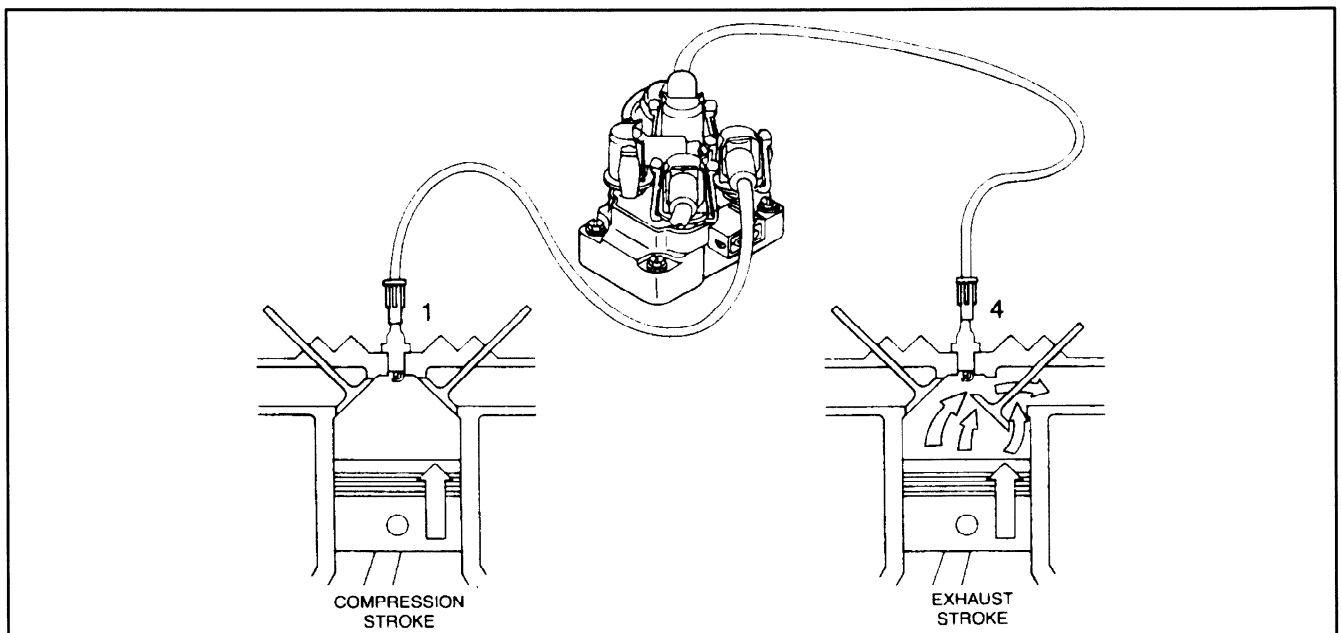

Engine Speed and C/S Position

The crankshaft position and speed information comes to the ICM from the Crankshaft Position Sensor (CKP), also known as the Variable Reluctance Sensor (VRS). The CKP

is triggered by teeth cast into the engine side of the flywheel. The 36-1 teeth, spaced 10° apart, indicate to the ICM the crankshaft speed. The missing tooth indicates crankshaft position.

DESCRIPTION AND OPERATION (Continued)

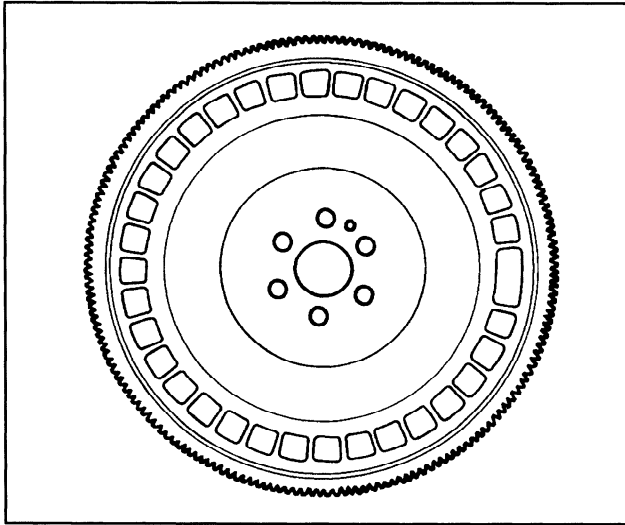

Engine Load

The engine load information is processed into the ICM's electronics by a pressure transducer located within the ICM. A vacuum line connects the transducer to the engine intake manifold. The engine vacuum is proportional to its load.

Engine Temperature

The Engine Coolant Temperature (ECT) Sensor sends engine temperature information to the ICM. The ECT sensor is located in the intake manifold water jacket.

Fuel Octane Level Adjustment

This input to the ICM retards the spark according to the Spark Timing table on page 13. This input is not usually used in the U.S.

The ICM module **outputs** are:

Ignition Coil Driver

The ICM switches two ignition coils on and off at the correct times to give the desired spark advance.

Sensor Fail-safe

If the ICM identifies a failure of any of its inputs, other than the engine speed/position sensor, it will substitute a fixed value for that input until such time that the fault on the input is rectified. A failed sensor is defined as the instantaneous reading of a sensor being made that is either above or below the maximum or minimum reading as defined by the system constants below:

Engine Coolant Temperature	minimum -39°C	(-38°F)
	maximum 112 °C	(234°F)
Manifold Absolute Pressure	minimum 21 kPa	(6.22" Hg)
	maximum 101 kPa	(29.91" Hg)

Ignition timing is adjusted constantly by the ICM. Many factors, including all the sensors affect the final ignition setting.

Cranking Mode

Cranking mode is the area of engine operating speed within which the ignition timing is at a static position. The static spark advance is fixed at 10 degrees BTDC up to 250 RPM.

Run Mode

In this mode the RPM is above 250 and the spark advance is calculated in three main sections which are added together. The ICM sections are: Base Spark Advance (BSA) plus Spark Advance Offset Temperature (SAOT) plus Spark Advance Offset Detonation ECT (SAODE).

The final spark advance is then corrected, for propagation delays and finally the spark advance is limited by the system ranges and the spark slew rate limited.

The Base Spark Advance (BSA) is calculated by the ICM looking at speed and load inputs.

The Spark Advance Offset Temperature (SAOT) will change ignition timing from the function of Engine Coolant Temperature (ECT). This allows the spark advance to be altered during cold engine conditions to improve starting and operation.

Spark Advance Offset Detonation ECT (SAODE) the ignition timing is offset as a function of Engine Coolant Temperature (ECT). This allows the spark advance to be reduced during hot engine conditions to avoid detonation and allow base spark advance to be calibrated near to the best performance curve.

Transient Mode

This function is to provide detonation protection when the engine load is increased rapidly by fast opening of the throttle plate. Rapid increases in engine load are determined by large changes in consecutive Manifold Absolute Pressure (MAP) values to the ICM.

Overspeed Mode

If the instantaneous engine speed is greater than the maximum speed threshold, then the spark events are terminated until the instantaneous engine speed falls below 6375 RPM. During this time all other ICM calculations are performed as normal.

SERVICE ADJUSTMENTS AND CHECKS

1. Each 400 hours of engine operation remove the spark plugs and clean & adjust the electrode.
2. Clean and visually check spark plug high tension leads and check for secure fit, replace if necessary.

The ICM must be mounted above the intake manifold vacuum fitting to prevent fuel from entering the ICM chamber

The connecting rubber hose must be compatible with gasoline and be as short as possible. It is recommended that a fuel vapor trap be used in line in the connecting hose.

REMOVAL AND INSTALLATION

Ignition Coil

Removal

1. Disconnect battery ground lead.
2. Disconnect ignition coil multiplug.

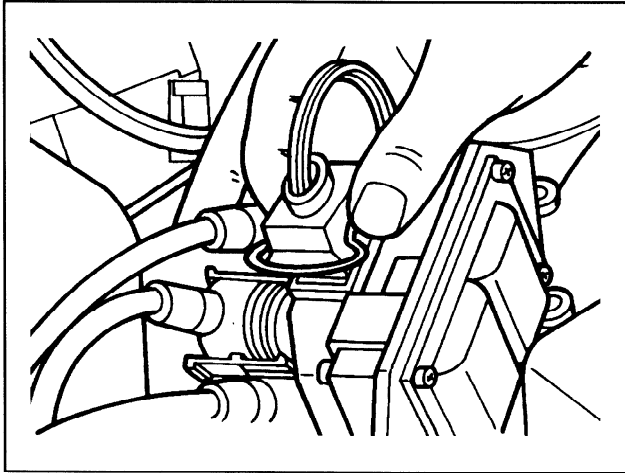

3. Compress 2 lugs and disconnect HT leads at coil.

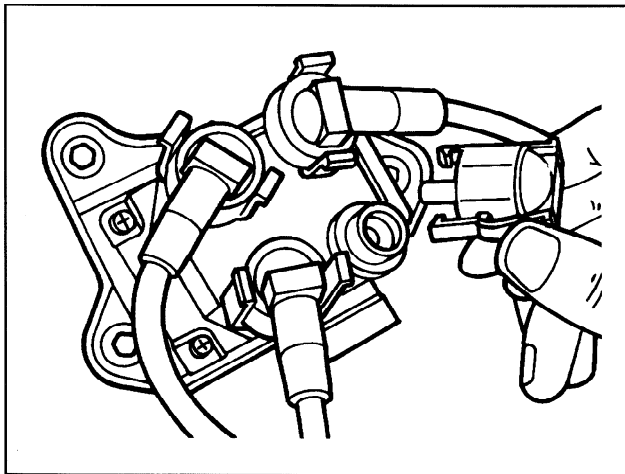

4. Remove three screws and detach coil assembly.

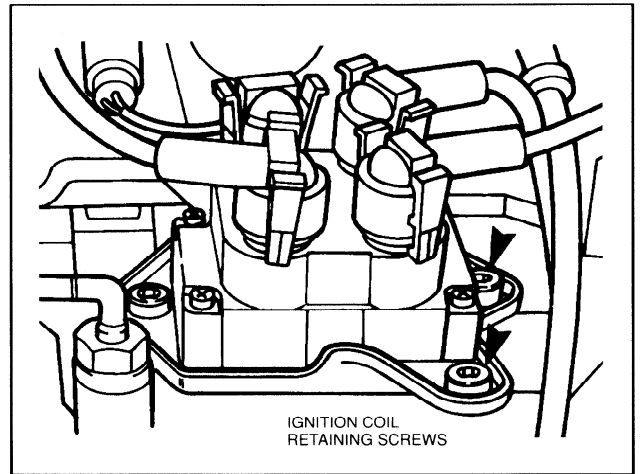

Installation

1. Position coil assembly, secure with three screws.
2. Connect HT leads at coil, ensuring that locking tabs snap into position.
NOTE: HT connections at coil are marked 1 to 4. It is important that each HT lead is connected in correct sequence.
3. Connect ignition coil multiplug.
4. Connect battery ground lead. Start engine and check coil operation.

Engine Speed Sensor

Removal

1. Disconnect battery ground cable.
2. Disconnect multiplug from sensor. Remove engine speed sensor, (one screw).

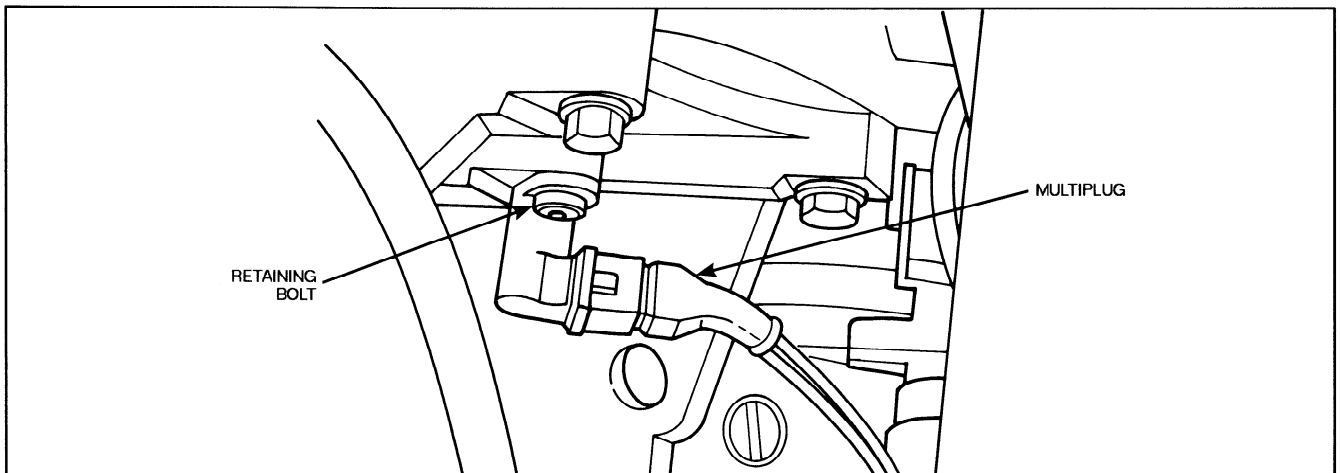

REMOVAL AND INSTALLATION (Continued)

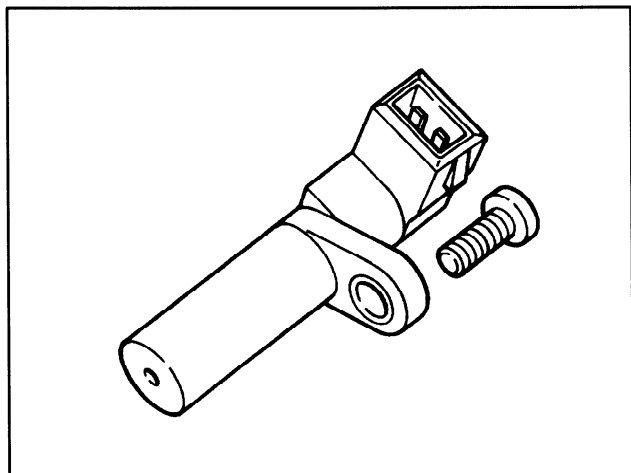

Installation

1. Fit engine speed sensor and secure with screw.
2. Refit sensor multiplug.
3. Connect battery ground cable.

Engine Coolant Temperature Sensor

Removal

1. Disconnect battery and release cooling system pressure.
WARNING: WHEN RELEASING SYSTEM PRESSURE, COVER CAP WITH A THICK CLOTH TO PREVENT COOLANT SCALDING.
2. Place a clean drain tray below engine under radiator drain plug and remove drain plug. To assist draining remove radiator cap.
3. Remove temperature sensor multiplug, located below the intake manifold. To remove multiplug, pull on multiplug, do not pull on wiring.
4. Unscrew sensor from intake manifold

Installation

1. Install sensor into inlet manifold, do not overtighten sensor. Connect multiplug, ensuring that locking tabs snap into position.
2. Replace radiator drain plug and refill system with correct solution. Remove rubber blanking cap on water outlet. When coolant is evident, refit blanking cap. Fill container to "maximum" mark allowing time for air in system to bubble through. Install radiator cap.
3. Connect battery and start engine. Allow engine to warm to normal operating temperature. Check, and if necessary, add coolant.

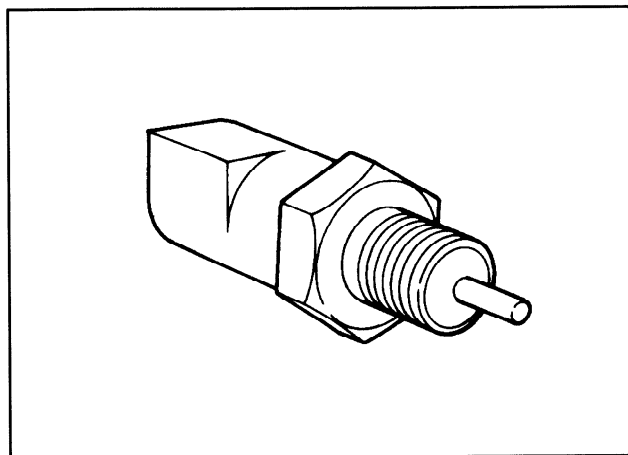

DIAGNOSING AND TESTING DIS

DIS Diagnosis Equipment

To accurately diagnose DIS, certain diagnostic equipment and tools are required. In addition, the suggested diagnostic equipment may make the job easier and more convenient.

Prior to diagnosing DIS, obtain the following test equipment or equivalent.

- SPARK TESTER, NEON BULB TYPE (CHAMPION CT-436 OR EQUIVALENT)

There is no need to disconnect a plug wire; just place this spark tester on a spark plug wire to determine if spark is being provided to the plug. This is especially useful for those hard to reach plug wires.

- SPARK TESTER GAP TYPE (SPECIAL SERVICE TOOL D81P-6666-A OR EQUIVALENT)

Connect this gap type spark tester between any spark plug wire and engine ground to instantly determine if spark is being provided to the plug. A spark plug with a broken side electrode is not sufficient to check for spark and may lead to incorrect results.

- VOLT-OHMMETER (ROTUNDA 014-00575 OR EQUIVALENT)

A volt-ohmmeter is essential for gathering system operating data during diagnosis, testing, and engine servicing procedures. A digital volt-ohmmeter (DVOM) can also be used for general purpose electrical troubleshooting on conventional starting and charging systems.

- 12-14 VOLT TEST LAMP TIMING LIGHT (ROTUNDA 059-00006 OR EQUIVALENT)

This timing light uses an inductive pickup for convenience and safety on 12 volt systems. This timing light includes a tachometer which reads from zero to 3000 RPM.

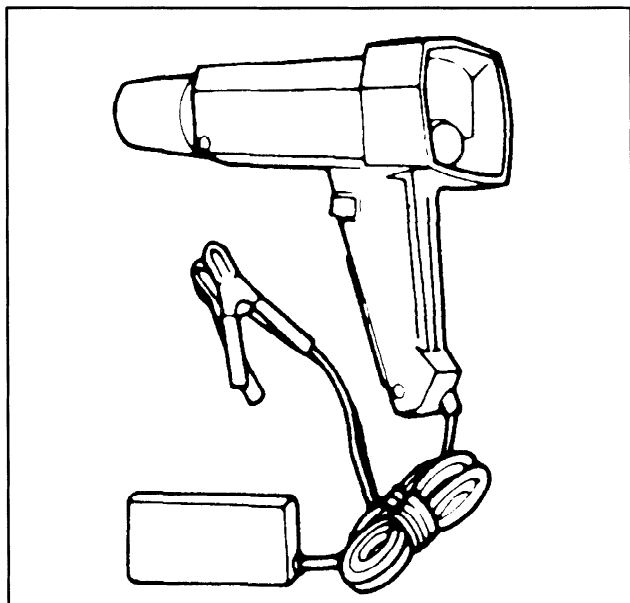

DIS Diagnosing

This check will test the engine harness, connectors and sensors for both continuity & resistance.

1. Remove the 12 pin ICM harness plug from the ICM module. Pins 1 and 5 are not used, and therefore do not have female connectors in the 12 pin harness connector plug.
2. Check the following circuits with the volt-ohmmeter (with the sensors connected) per the chart on page 12, with reference to the wiring diagram on page 14.

If the DIS Engine Harness checks are not to the chart specifications (page 12), complete the following:

- Remove the wire harness connector to the ICM.
- Remove each sensor or component from the harness.
- Using a high impedance digital volt-ohmmeter (DVOM) check each wire for continuity or resistance.
- If the wire harness has open circuits or resistance higher than specifications repair or replace the harness.
- If the wire harness checks are to specifications, reconnect each sensor and component and complete another DIS Engine Harness check.
- If the same sensor or component circuit does not test to specifications — replace that sensor or coil.
- If the engine will not start and/or run install a new module and make a normal start.

DIS Cleaning and Inspection

Spark Plugs

Clean spark plugs as necessary using a wire brush or professional spark plug cleaner (follow manufacturer's instructions). Inspect the firing tip. Refer to Spark Plug Inspection Chart. Replace spark plugs if they are worn or damaged.

Ignition Coil

Wipe the coil towers with a clean cloth dampened with soap and water. Remove any soap film and dry with compressed air. Inspect for cracks, carbon tracking and dirt.

Ignition Wires

Wipe the spark plug wire set with a clean, damp cloth before inspecting it. Without removing the spark plug wire set from the spark plugs or ignition coil, inspect the wire set for visible damage such as cuts, pinches, or cracked or torn boots. Refer to Ignition Wires Removal and Installation in this section and replace as necessary.

DIAGNOSING AND TESTING DIS (Continued)

Spark Plug Inspection Chart

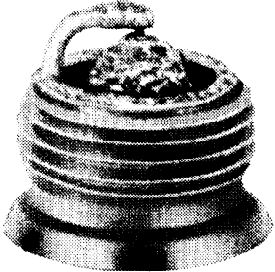
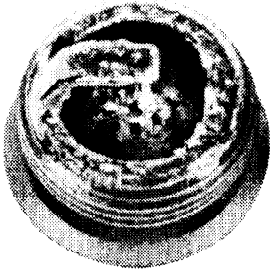
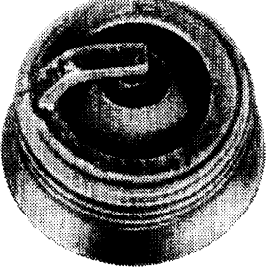
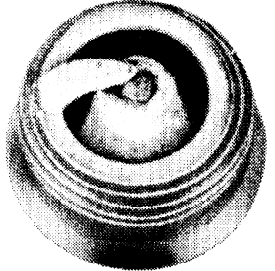
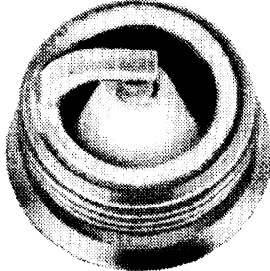
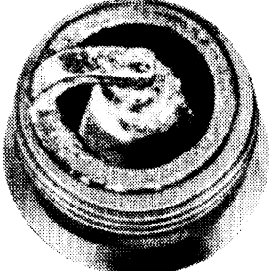
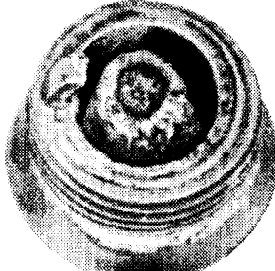
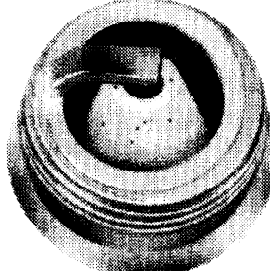
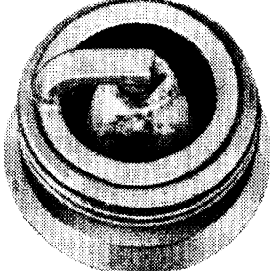
<p style="text-align: center;">GAP BRIDGED</p>  <p>IDENTIFIED BY DEPOSIT BUILD-UP CLOSING GAP BETWEEN ELECTRODES. CAUSED BY OIL OR CARBON FOULING. REPLACE PLUG, OR, IF DEPOSITS ARE NOT EXCESSIVE, THE PLUG CAN BE CLEANED.</p>	<p style="text-align: center;">OIL FOULED</p>  <p>IDENTIFIED BY WET BLACK DEPOSITS ON THE INSULATOR SHELL BORE ELECTRODES CAUSED BY EXCESSIVE OIL ENTERING COMBUSTION CHAMBER THROUGH WORN RINGS AND PISTONS, EXCESSIVE CLEARANCE BETWEEN VALVE GUIDES AND STEMS, OR WORN OR LOOSE BEARINGS. REPLACE THE PLUG. IF ENGINE IS NOT REPAIRED, USE A HOTTER PLUG.</p>	<p style="text-align: center;">CARBON FOULED</p>  <p>IDENTIFIED BY BLACK, DRY FLUFFY CARBON DEPOSITS ON INSULATOR TIPS, EXPOSED SHELL SURFACES AND ELECTRODES. CAUSED BY TOO COLD A PLUG, WEAK IGNITION, DIRTY AIR CLEANER, DEFECTIVE FUEL PUMP, TOO RICH A FUEL MIXTURE, IMPROPERLY OPERATING HEAT RISER OR EXCESSIVE IDLING. CAN BE CLEANED.</p>
<p style="text-align: center;">WORN</p>  <p>IDENTIFIED BY SEVERELY ERODED OR WORN ELECTRODES. CAUSED BY NORMAL WEAR. SHOULD BE REPLACED</p>	<p style="text-align: center;">NORMAL</p>  <p>IDENTIFIED BY LIGHT TAN OR GRAY DEPOSITS ON THE FIRING TIP.</p>	<p style="text-align: center;">LEAD FOULED</p>  <p>IDENTIFIED BY DARK GRAY, BLACK, YELLOW OR TAN DEPOSITS OR A FUSED GLAZED COATING ON THE INSULATOR TIP. CAUSED BY HIGHLY LEADED GASOLINE. REPLACE THE PLUG.</p>
<p style="text-align: center;">PRE-IGNITION</p>  <p>IDENTIFIED BY MELTED ELECTRODES AND POSSIBLY BLISTERED INSULATOR. METALLIC DEPOSITS ON INSULATOR INDICATE ENGINE DAMAGE. CAUSED BY WRONG TYPE OF FUEL, INCORRECT IGNITION TIMING OR ADVANCE, TOO HOT A PLUG, BURNT VALVES OR ENGINE OVERHEATING. REPLACE THE PLUG.</p>	<p style="text-align: center;">OVERHEATING</p>  <p>IDENTIFIED BY A WHITE OR LIGHT GRAY INSULATOR WITH SMALL BLACK OR GRAY BROWN SPOTS AND WITH BLUISH-BURNT APPEARANCE OF ELECTRODES, CAUSED BY ENGINE OVERHEATING. WRONG TYPE OF FUEL, LOOSE SPARK PLUGS, TOO HOT A PLUG, LOW FUEL PUMP PRESSURE OR INCORRECT IGNITION TIMING. REPLACE THE PLUG.</p>	<p style="text-align: center;">FUSED SPOT DEPOSIT</p>  <p>IDENTIFIED BY MELTED OR SPOTTY DEPOSITS RESEMBLING BUBBLES OR BLISTERS. CAUSED BY SUDDEN ACCELERATION, CAN BE CLEANED IF NOT EXCESSIVE. OTHERWISE REPLACE PLUG.</p>

DIAGNOSING AND TESTING DIS (Continued)

DIS ENGINE HARNESS CHECKS (ICM HARNESS CONNECTOR REMOVED; ALL SENSORS CONNECTED TO HARNESS)

Test No.	Harness Connector PIN Nos.	DVOM Reading	Description of Circuit, Wires Checked & Circuit Function
1	2 to 3	200-300 Ω	Engine RPM & Crank Position (Wires 264, 265 & CKP Sensor)
2	4 to 10	105,000 Ω at 0°C (32°F)	Eng. Coolant Temp. Sensor (Wires 354, 354A and 359)
3	6 to 7	Continuity (0 Ω)	ICM Spark Advance. A single wire connects Pins 6 and 7 in a closed loop. Cutting and grounding this wire changes the spark advance. See the following table for values.
4	11 to 12	0.5-1.0 VDC	Check for continuity in the DIS coil circuit (Wires 850/850A to 852/852A)
5	Coil Secondaries #1 to #4	14,000 Ω \pm 5%	Remove the four spark plug wires and measure the secondary resistance from #1 to #4.
6	Coil Secondaries #2 to #3	14,000 Ω \pm 5%	Remove the four spark plug wires and measure the secondary resistance from #2 to #3.

SPARK TIMING

Action	Effect on Spark Timing
Loop between Pins 6 and 7 closed or open	None
Ground Pin 7	Retard Base Spark by 1-2 degrees
Ground Pin 6	Retard Base Spark by 2-4 degrees
Ground Pins 6 and 7	Retard Base Spark by 6-8 degrees

NOTE: For generator set application, the vacuum line between the intake manifold and the ignition module may be disconnected.

ENGINE COOLANT TEMPERATURE SENSOR CHARACTERISTICS

Temperature		Column A Sensor (Ohms) \pm 5%	Column B Sensor & Harness (Ohms) \pm 5%
°C	°F		
-30	-22	481,000	491,000
-20	4	271,200	281,200
-10	14	158,000	168,000
0	32	95,000	105,000
10	50	58,750	68,750
20	68	37,300	47,300
30	86	24,270	34,270
40	104	16,150	26,150
50	122	10,970	20,970
60	140	7,600	17,600
70	158	5,360	15,360
80	176	3,840	13,840
90	194	2,800	12,800
100	212	2,070	12,070
110	230	1,550	11,550
120	248	1,180	11,180
130	266	903	10,903
140	284	701	10,701
150	302	550	10,550

1. Use column A to check the ECT sensor resistance at the sensor (not through the harness).
2. Use column B to check the ECT sensor resistance at Pin 4 of the ICM connector. This value includes the 10,000 ohm series resistor in the harness.

DIAGNOSING AND TESTING DIS (Continued)

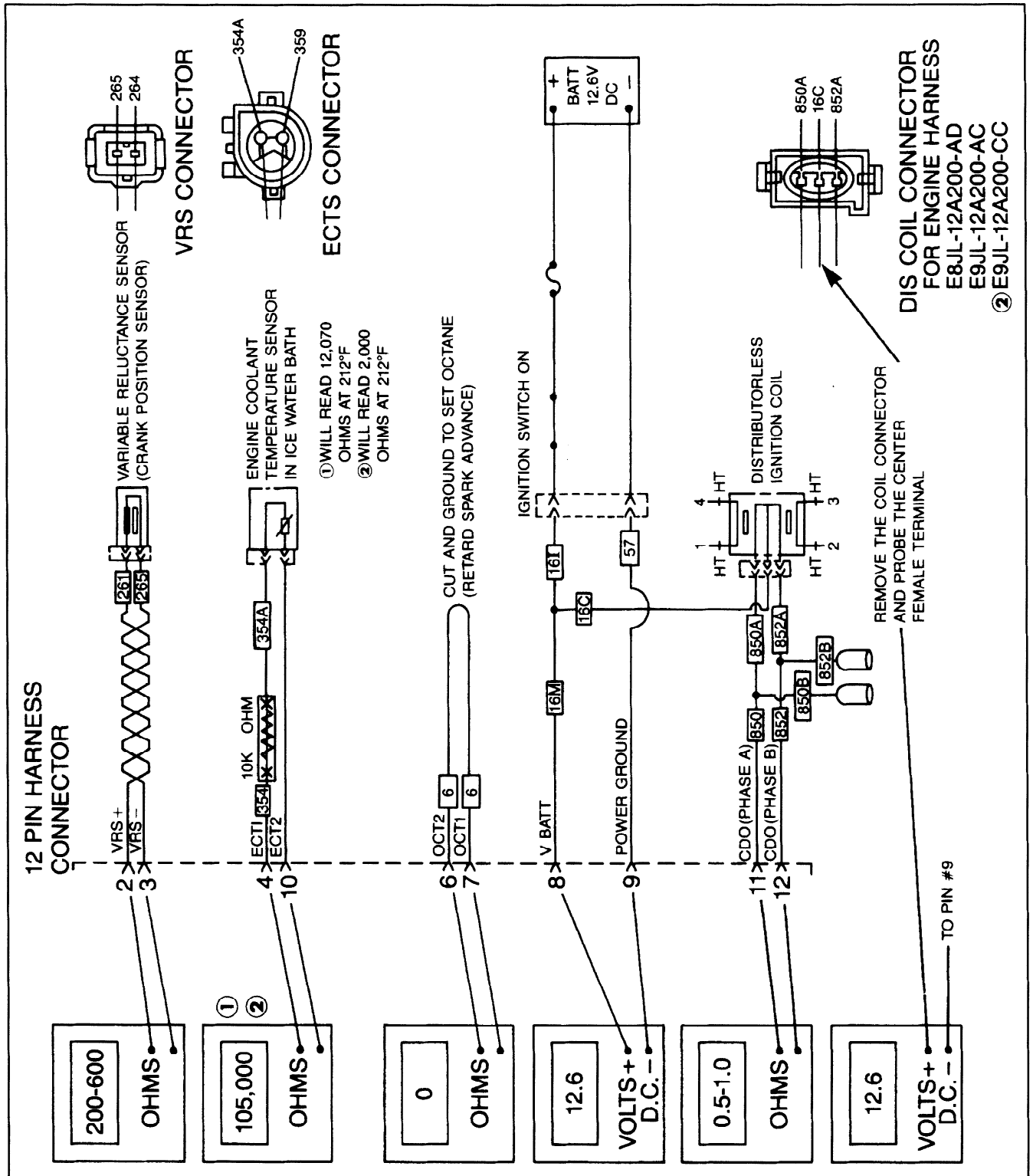

DIAGNOSING AND TESTING DIS (Continued)**WIRING HARNESS CIRCUIT IDENTIFICATION – F4JL-14305-AA**

No.	Circuit Description	GA	Base Color	Stripe Color
16I	Ignition Switch to Splice	18	Red	Green
852B	Splice to Electronic Governor or Tachometer	18	Yellow	White
852A	Splice to DIS Coil 2	18	Yellow	White
850B	Splice to Electronic Governor or Tachometer	18	Yellow	Black
850A	Splice to DIS Coil 1	18	Yellow	Black
354A	Resistor to ECT Sensor	18	Brown	White
16C	DIS Coil to Splice	18	Red	Green
852	ICM (Ignition Control Module, or UESC) to Splice	18	Yellow	White
850	ICM to Splice	18	Yellow	Black
359	ICM to ECT Sensor Ground	18	Green	White
57	ICM to Battery Ground	18	Black	
16M	ICM Pin 8 to Splice	18	Red	Green
6	ICM Spark Retard 2° OS1	18	Brown	
6	ICM Spark Retard 4° OS2	18	Brown	
354	ICM to Resistor	18	Brown	White
265	ICM to Crankshaft Position Sensor (CKP) (-)	18	Green	
264	ICM to Crankshaft Position Sensor (CKP) (+)	18	White	
152	"ACC" Terminal of Ign Sw to Generator-Mounted Regulator	18	Yellow	
730	Voltmeter Feed	18	Red	
170	Carburetor Solenoid	18	Blue	Red
57P	Ground Circuit – Pressure Gauge	18	Black	
57S	Ground Circuit Switch – Gauge Relay	18	Black	
57T	Ground Circuit – Temperature Gauge	18	Black	
57V	Ground Circuit – Voltmeter	10	Black	
38	GEN "BATT" Terminal to Starter Solenoid "BATT" Terminal	10	Black	Red
32	Ignition Switch to Starter Motor Relay	18	Red	Blue
21	Starter Solenoid Battery Terminal to Ignition Switch Feed	14	Yellow	

DIAGNOSING AND TESTING DIS (Continued)

USER NOTES:

- NOTE THE WIRE LOOP FROM UESC PIN 6 TO PIN 7. IF THE ENGINE IS OPERATED WITH LOW OCTANE FUEL IT MAY BE NECESSARY TO RETARD THE SPARK. THIS MAY BE DONE BY CUTTING OPEN THE LOOP AND GROUNDING THE WIRE WHICH GOES TO PIN 6 TO PIN 7 OR BOTH
 TO RETARD 4° GROUND WIRE TO PIN 7
 TO RETARD 10° GROUND WIRE TO PIN 6
 TO RETARD 18° GROUND WIRE TO PIN 6 & 7
- THE UESC MODULE MUST BE MOUNTED SOMEWHAT ABOVE THE LEVEL OF THE INTAKE MANIFOLD. THIS IS SO THAT FUEL OR CONDENSED FUEL VAPORS CANNOT DRAIN (THRU THE VACUUM LINE) INTO THE MODULE DURING OPERATION OR STORAGE
- WIRE 354 CONTAINS A 10 KΩ SERIES RESISTOR. FROM THE RESISTOR TO THE ECT SENSOR CONNECTOR THIS CIRCUIT IS CALLED 354A.

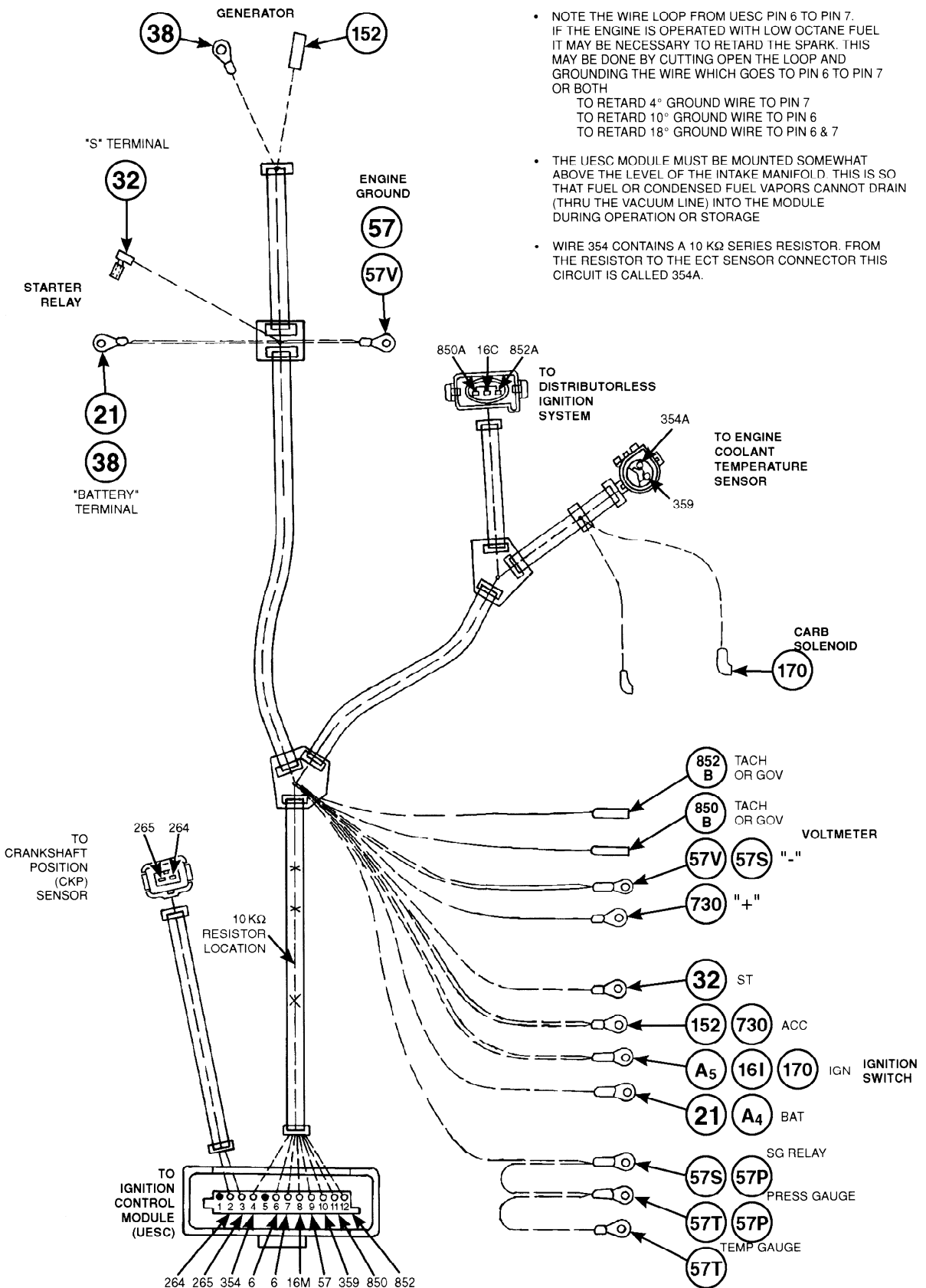

DIAGNOSING AND TESTING DIS (Continued)**WIRING HARNESS CIRCUIT IDENTIFICATION – F4JL-14305-BA**

No.	Circuit Description	GA	Base Color	Stripe Color
16I	Ignition Switch to Splice	18	Red	Green
852B	Splice to Electronic Governor or Tachometer	18	Yellow	White
852A	Splice to DIS Coil 2	18	Yellow	White
850B	Splice to Electronic Governor or Tachometer	18	Yellow	Black
850A	Splice to DIS Coil 1	18	Yellow	Black
354A	Resistor to ECT Sensor	18	Brown	White
16C	DIS Coil to Splice	18	Red	Green
852	ICM (Ignition Control Module, or UESC) to Splice	18	Yellow	White
850	ICM to Splice	18	Yellow	Black
359	ICM to ECT Sensor Ground	18	Green	White
57	ICM to Battery Ground	18	Black	
16M	ICM Pin 8 to Splice	18	Red	Green
6	ICM Spark Retard 2° OS1	18	Brown	
6	ICM Spark Retard 4° OS2	18	Brown	
354	ICM to Resistor	18	Brown	White
265	ICM to Crankshaft Position Sensor (CKP) (-)	18	Green	
264	ICM to Crankshaft Position Sensor (CKP) (+)	18	White	
152	Terminal Strip to Generator-Mounted Regulator	18	Yellow	
170	Carburetor Solenoid	18	Blue	Red
39	Temperature Gauge to Temp Sending Unit	18	Red	White
31	Oil Pressure Indicator Light to Oil Pressure Switch	18	White	Red
57T	Ground Circuit – Temperature Gauge	10	Black	
38	GEN “BATT” Terminal to Starter Solenoid “BATT” Terminal	10	Black	Red
32	Ignition Switch to Starter Motor Relay	18	Red	Blue
21	Starter Solenoid Battery Terminal to Ignition Switch Feed	14	Yellow	

DIAGNOSING AND TESTING DIS (Continued)

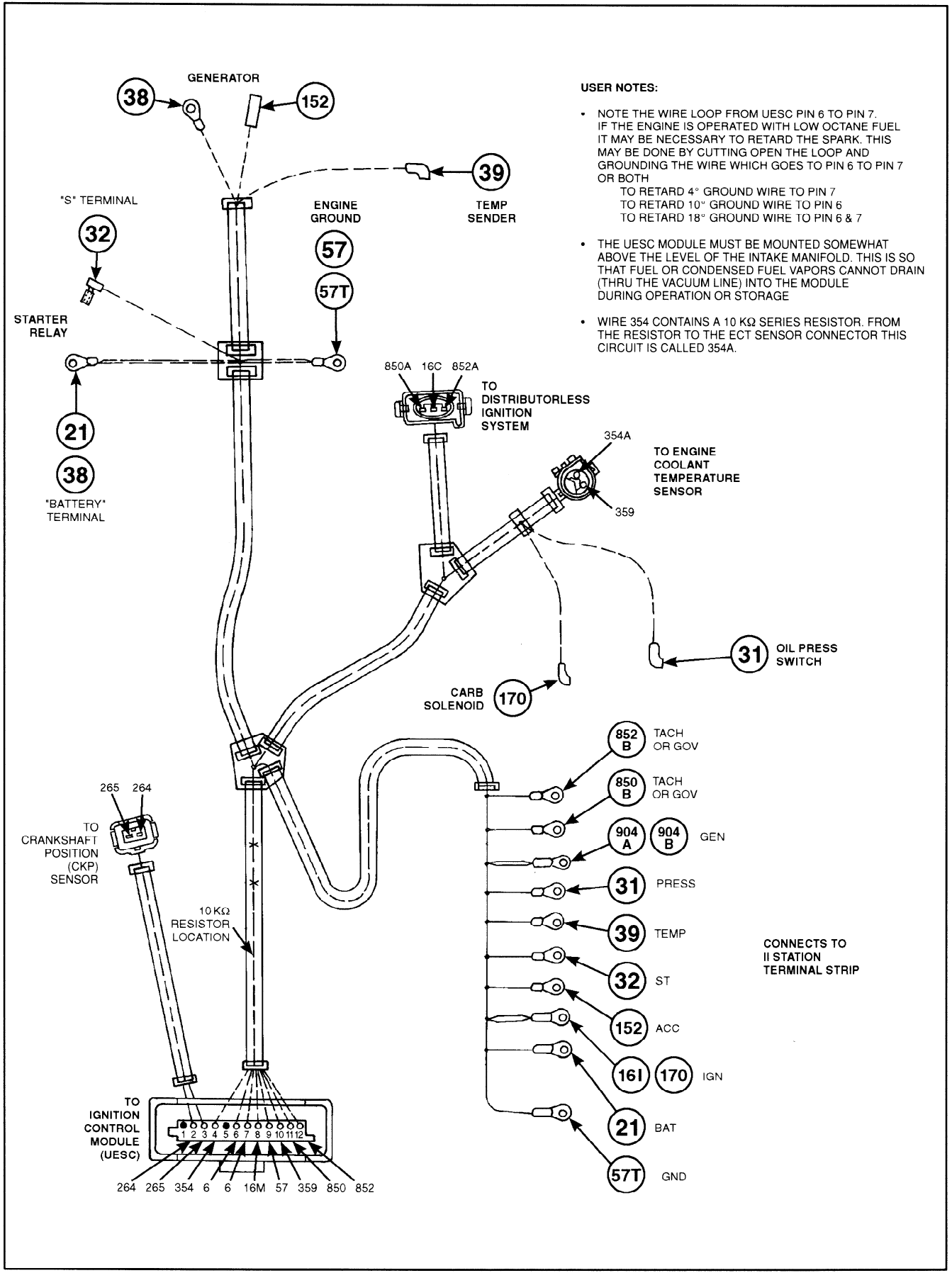

USER NOTES:

- NOTE THE WIRE LOOP FROM UESC PIN 6 TO PIN 7. IF THE ENGINE IS OPERATED WITH LOW OCTANE FUEL IT MAY BE NECESSARY TO RETARD THE SPARK. THIS MAY BE DONE BY CUTTING OPEN THE LOOP AND GROUNDING THE WIRE WHICH GOES TO PIN 6 TO PIN 7 OR BOTH
 - TO RETARD 4° GROUND WIRE TO PIN 7
 - TO RETARD 10° GROUND WIRE TO PIN 6
 - TO RETARD 18° GROUND WIRE TO PIN 6 & 7
- THE UESC MODULE MUST BE MOUNTED SOMEWHAT ABOVE THE LEVEL OF THE INTAKE MANIFOLD. THIS IS SO THAT FUEL OR CONDENSED FUEL VAPORS CANNOT DRAIN (THRU THE VACUUM LINE) INTO THE MODULE DURING OPERATION OR STORAGE
- WIRE 354 CONTAINS A 10 KΩ SERIES RESISTOR. FROM THE RESISTOR TO THE ECT SENSOR CONNECTOR THIS CIRCUIT IS CALLED 354A.

SECTION TITLE	PAGE	SECTION TITLE	PAGE
BASIC ENGINE	01-1	STARTING SYSTEM	05-1
IGNITION SYSTEM – DISTRIBUTORLESS	02-1	GOVERNOR	06-1
FUEL SYSTEM	03-1	COOLING SYSTEM	07-1
EMISSION CONTROL SYSTEM	03A-1	SPECIFICATIONS	08-1
CHARGING SYSTEM	04-1		

SECTION 03 — Fuel System

SUBJECT	PAGE	SUBJECT	PAGE
DESCRIPTION AND OPERATION	03-3	ZENITH MODEL #33 CARBURETOR	03-7
General Description	03-3	Operation and Service	03-7
Identification	03-3	Fuel Supply System	03-7
DIAGNOSIS AND TESTING	03-4	Idle System	03-7
General Information	03-4	High Speed System	03-8
FUEL PUMP	03-5	Accelerating Pump System	03-9
Description	03-5	Disassembly	03-11
Diagnosis and Testing	03-5	Cleaning and Inspection	03-11
Pressure Tests	03-5	Assembly of Air Intake	03-11
Capacity (Volume) Test	03-5	Assembly of Fuel Bowl	03-11
REMOVAL AND INSTALLATION	03-6	Automatic Choke Operation	03-12
Fuel Pump Assembly	03-6	Choke Pull-Off	03-13
		Automatic Choke Setup Procedure	03-13
		Adjusting the Choke Pull-Off	03-13
		Adjusting the Thermostatic Spring	03-14

BLANK

DIAGNOSIS AND TESTING

General Information

Water and dirt that accumulate in the fuel tank can cause a restricted fuel line or filter and malfunction of the fuel pump or carburetor. Condensation, which is the greatest source of water entering the fuel tank, is formed by moisture in the air when it strikes the cold interior walls of the fuel tank.

If the accumulation of dirt and water in the filter is excessive, the fuel tank should be removed and flushed, and the line from the fuel pump to the tank should be blown out.

Air leakage in the fuel inlet line can cause low fuel pump pressure and volume.

A restricted fuel tank vent can cause low fuel pump pressure and volume and can result in collapsed inlet hoses or a collapsed fuel tank.

High or low pressure are the two most likely fuel pump troubles that will affect engine performance. Low pressure will cause a lean mixture and fuel starvation at high speeds and excessive pressure will cause high fuel consumption and carburetor flooding.

Dirt accumulation in the fuel and air passages, improper idle adjustments, and improper fuel level are the major sources of carburetor troubles.

FUEL PUMP

Description

A single action mechanical fuel pump is standard on this engine. It is located on the right side of the engine and is driven by a lobe on the camshaft.

The pump is permanently sealed and is serviced by replacing the entire unit.

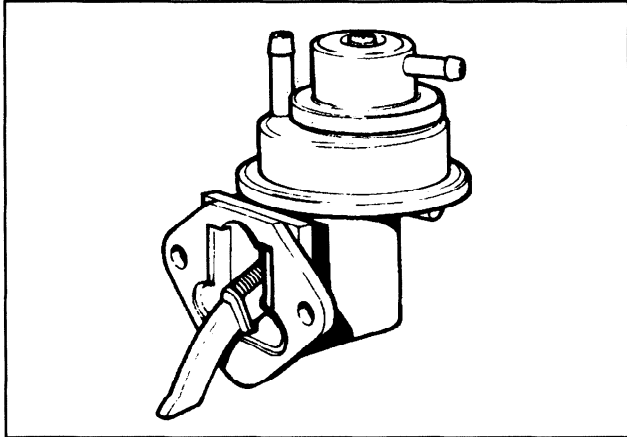

Diagnosis and Testing

To determine that the fuel pump is in satisfactory operating condition, tests for both fuel pump pressure and fuel pump capacity (volume) should be performed.

The tests are performed with the fuel pump installed on the engine and the engine at normal operating temperature at idle speed.

Before the tests, make sure the replaceable fuel filter has been changed within the recommended maintenance mileage interval. When in doubt, install a new filter.

Pressure Tests

Refer to the fuel pump specification and note the fuel pump pressure and capacity (volume) design tolerances.

1. Remove the air cleaner assembly. Disconnect the fuel inlet line or the fuel filter at the carburetor. **Use care to prevent combustion due to fuel spillage.**
2. Connect pressure gauge, restrictor and flexible hose between the fuel filter and carburetor.

NOTE: Inside diameter of smallest passage in test flow circuit must not be smaller than 5.59 mm (0.220 in).

3. Position the flexible fuel outlet hose and the restrictor so the fuel can be discharged into the graduated container.

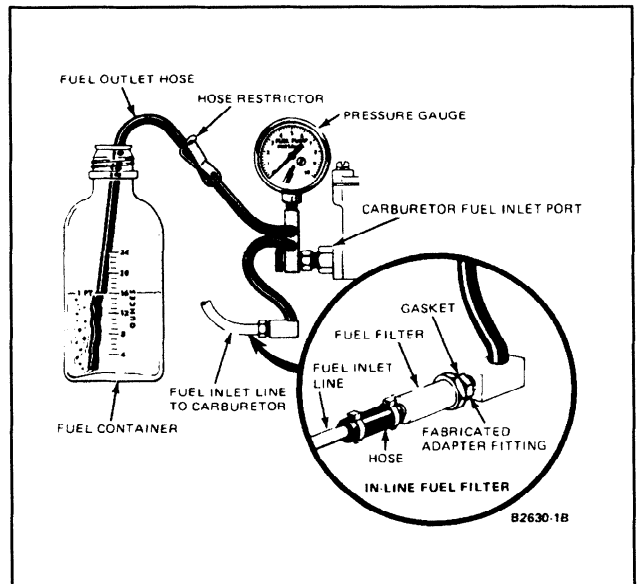

4. Before taking a pressure reading operate the engine at the specified idle rpm and vent the system into the container by opening the hose restrictor momentarily.
5. Close the hose restrictor, allow the pressure to stabilize, and note the reading.

If the pump pressure is not within specifications with temperatures normalized at idle speed and in neutral and the fuel lines and filter are in satisfactory condition, the pump is worn or damaged and should be replaced.

If the pump pressure is within specifications, perform the tests for fuel capacity (volume).

Capacity (Volume) Test

With the fuel pump pressure within specifications, test the capacity (volume) as follows:

1. Operate the engine at the specified idle rpm.
2. Open the hose restrictor and expel the fuel into the container, while observing the time required to expel 0.5 liters (one pint). Close the restrictor. 0.5 liters (one pint) or more of fuel should be expelled within the specified time limit (25 sec.).

If the pump volume is below specifications, repeat the test using an auxiliary fuel supply and a new fuel filter. If the pump volume meets specifications while using the auxiliary fuel supply, check for a restriction in the fuel supply from the tank and for the tank not venting properly.

REMOVAL AND INSTALLATION

Fuel Pump Assembly

Removal

1. Disconnect the inlet and outlet lines at the fuel pump.
2. Remove the pump attaching screws, then remove the pump and the gasket. Discard the gasket.

Installation

1. Remove all the gasket material from the mounting pad and pump flange. Apply oil-resistant sealer to both sides of a new gasket and to the threads on the attaching bolts.
2. Position the new gasket on the pump flange and hold the pump in position against the mounting pad. Make sure the rocker arm is riding on the camshaft eccentric. (Turn engine over until the fuel pump eccentric is on the low side of the stroke.)
3. Press the pump tight against the pad, install the attaching screws and alternately tighten them to specification.
4. Connect the fuel inlet and outlet lines.
5. Operate the engine and check for leaks.

ZENITH MODEL #33 CARBURETOR

Operation and Service

The Zenith model #33 carburetor is a single downdraft unit of two-piece construction, consisting of a cast aluminum air intake and throttle body with a fuel bowl. The single venturi is removable for easy adaptability to meet different size engine requirements.

The mounting flange holes are elongated to allow it to fit either the SAE 1" or 1-1/4" flange. A vacuum-operated accelerator pump is used.

Fuel Supply System

The fuel supply system consists of the threaded fuel inlet connection and fuel valve seat, fuel valve, float and fuel chamber. The fuel supply line is connected to the threaded inlet. Gasoline passes through the connection, through the fuel valve seat and past the fuel valve and into the fuel chamber. The level of the fuel in the fuel chamber is regulated by the float through its control of the fuel valve. The fuel valve does not open and close alternately. It assumes a more or less fixed-opening position as regulated by the float, sufficient to maintain a proper level in the fuel chamber equal to the fuel demand of the engine according to its speed and load.

Idle System

The idle system supplies fuel to run the engine at curb idle and also slow speeds until sufficient velocity is built up in the main venturi to operate the main system.

This system consists of the idle discharge holes, the idle adjusting needle, the passage or channel between the idle jet and the discharge holes, the idle air bleed, and the idle jet and pickup tubes. At idling speeds, manifold vacuum is transmitted through the primary idle discharge hole to the idle jet through a passage running through the throttle and air intake bodies. Fuel from the fuel bowl flows through the main jet into the fuel well where it is picked up by the pickup tube to be metered by the idle jet. As the fuel leaves the idle jet it is mixed with air from the idle air bleed, which is located just above the jet in the air intake, therefore a fuel and air mixture is provided just before the passage to the idle discharge holes. This air bleed calibration is to provide better control of the fuel delivery and to prevent the fuel in the bowl from being siphoned into the intake manifold through the idle system when the engine is shut off.

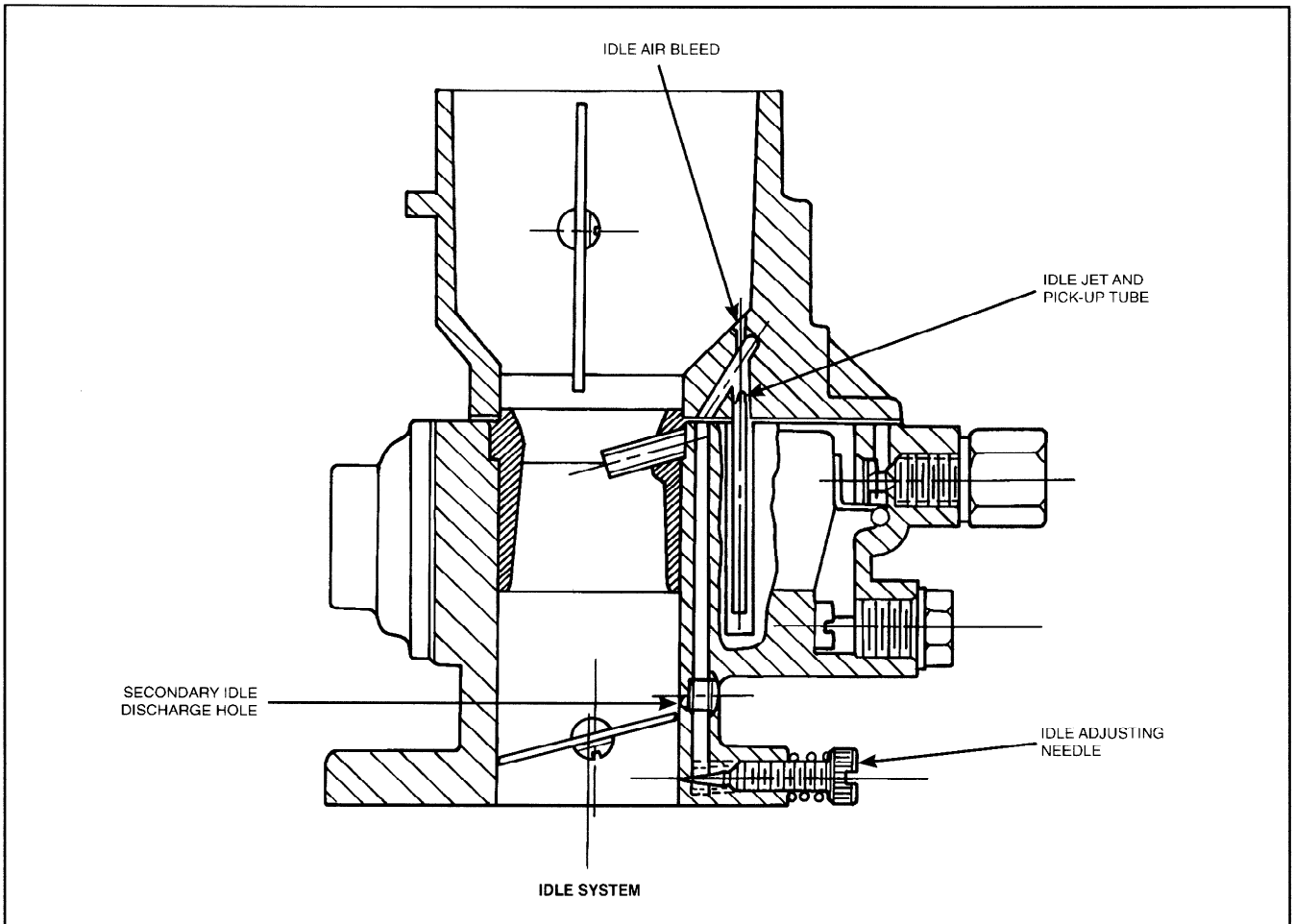

The discharge of the idle fuel into the air stream at curb idle is controlled by the idle adjusting needle in the primary idle discharge hole. Turning the needle in (clockwise)

restricts the primary discharge hole to provide a leaner mixture. Turning the needle out (counterclockwise) allows a richer mixture.

ZENITH MODEL #33 CARBURETOR (Continued)

As the throttle plate opens, extra fuel is discharged from the secondary idle discharge holes as the throttle plate passes them. This hole is precisely located from the closed throttle plate with the size and location depending on fuel requirements. As the throttle plate is opened wider, the idle system gradually ceases to function. The delivery of fuel through the high speed system increases as the throttle plate is advanced. Although the delivery of fuel through the idle system diminishes as the throttle plate approaches the wide open position, it continues to deliver a small volume of fuel contributing to the fuel delivered by the high speed system. It cannot be said that the idle system ceases to deliver fuel entirely at wide open throttle, but it must be made clear that the amount of fuel delivered from the idle system at wide open throttle is minute and relatively unimportant.

High Speed System

The high speed system consists of a venturi, a main jet, a well vent, and a well tube. This system also controls the mixture at part throttle speed.

The main jet controls fuel delivery from about one-quarter to three-quarters throttle opening. To maintain a proper mixture ratio, a small amount of air is admitted through the well vent. There are also air bleed holes located in the well tube at a point below the level of fuel in the well.

Introducing air into the well tube below the level of fuel, reduces the surface tension of the fuel and helps fuel flow at low suction. This bleed also restricts fuel flow through the main jet under high suctions.

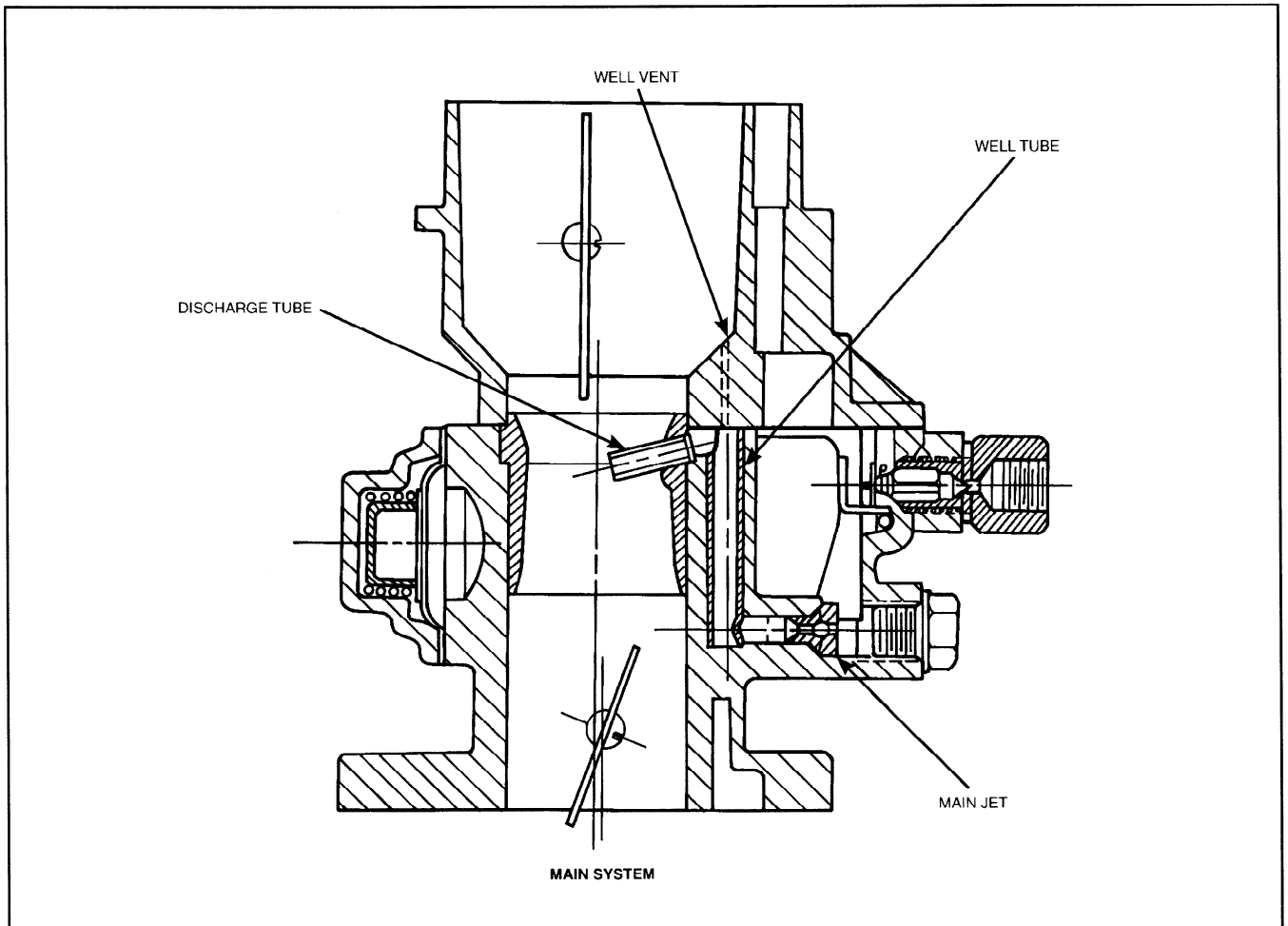

When the throttle plate is opened to a point just above the idle position, enough air passes through the carburetor to lower the pressure at the discharge tube. The float chamber is open to atmospheric pressure; consequently, the greater pressure in the float chamber will cause the fuel to flow from the fuel bowl through the main jet into the main well and well tube.

Air admitted through bleed holes in the well tube, an amount measured by the well vent, is mixed with the fuel. This mixture of fuel from the main well tube passes through the discharge tube in the venturi and is added to the air stream in the venturi. This mixture then passes into the intake manifold.

ZENITH MODEL #33 CARBURETOR (Continued)

Accelerating Pump System

The accelerating pump controls the amount of fuel that is discharged into the air stream on sudden throttle openings. When the throttle is opened suddenly, air rushes through the carburetor into the intake manifold and to the engine. This air is lighter than the liquid fuel and gets into motion

more quickly. That means that the air reaches the cylinders of the engine before the first charge of fuel supplied by the high speed system. A lean mixture would result momentarily in this case, and to counteract the condition, additional fuel must be supplied instantly. The supply of that extra fuel is the job of the accelerating pump system.

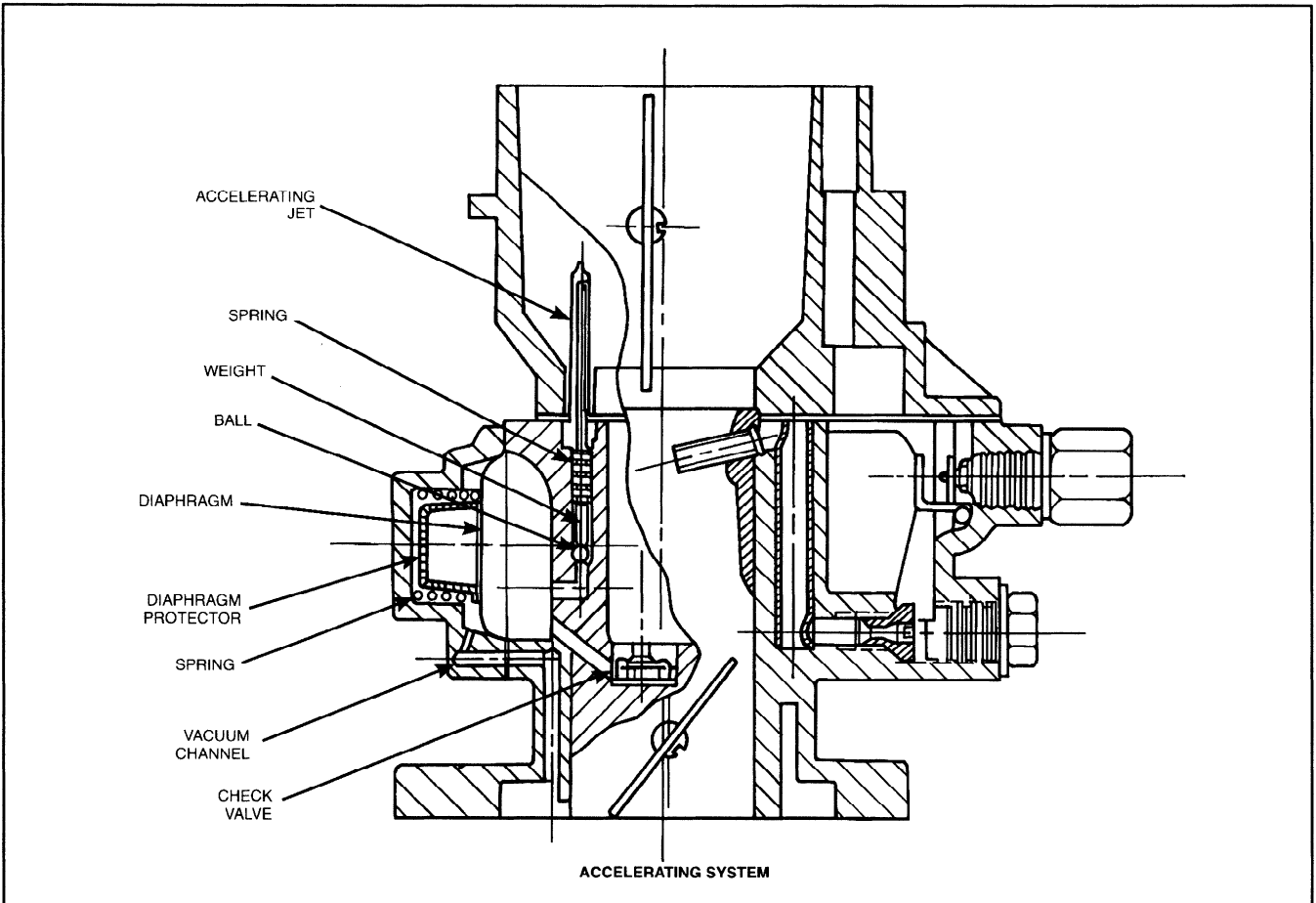

The accelerating system consists of the pump diaphragm assembly, accelerating jet, intake check valve, and three parts making up the refill check. The pump is vacuum operated. In this system the pump diaphragm is pulled against the pump spring by the engine manifold vacuum. When the throttle is opened, the pull on the diaphragm

drops allowing the spring to push the diaphragm against the fuel causing it to discharge through the accelerator jet. This amount may be varied by adjusting the travel of the pump spring. Such adjustment is made possible by changing the length of the diaphragm protector in the end of the pump spring.

ZENITH MODEL #33 CARBURETOR (Continued)

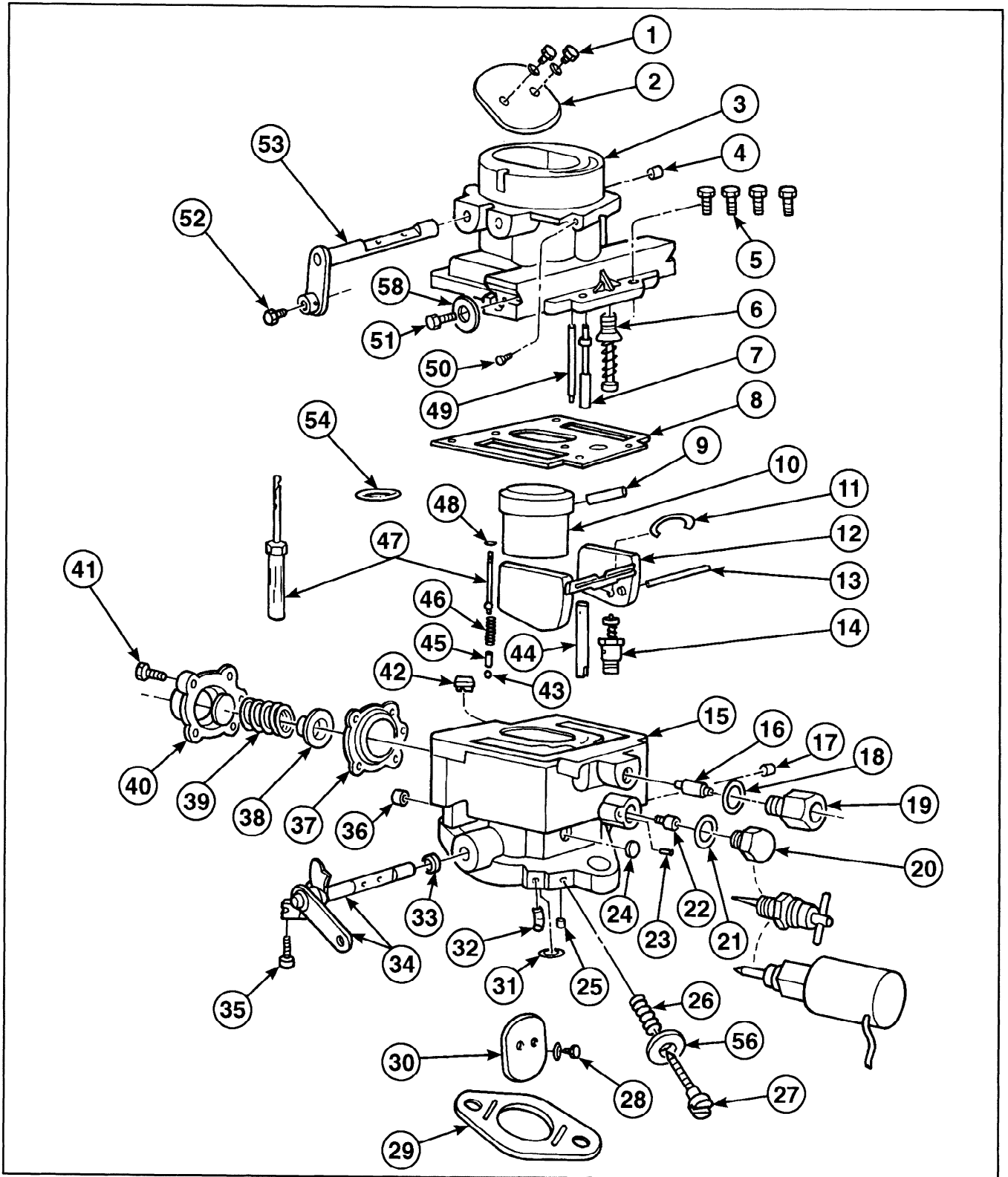

ZENITH MODEL #33 CARBURETOR (Continued)

Item	Description
1	Screw & L Washer – Choke Plate
2	Plate – Choke
3	Body – Air Intake
4*	Cup Plug – Shaft Hole
5	Screw – Intake Assembly
6	Piston – Vacuum Power
7*	Tube – Well Filler
8	Gasket – Intake to Body
9*	Tube – Discharge
10	Venturi
11	Retainer – Float Axle
12	Assembly – Float
13	Axle – Float
14	Valve – Power Jet
15	Body – Throttle
16	Valve – Fuel
17*	Cup Plug – Shaft Hole
18	Washer – Main Jet Plug
19	Seat – Fuel Valve
20	Plug – Main Jet
21	Washer – Main Jet Plug
22	Jet – Main
23*	Plug – Fuel Channel
24*	Welch Plug – Idle Port
25*	Plug – Idle Channel
26	Spring – Idle Adjusting Screw
27	Screw – Idle Adjusting
28	Screw & L Washer – Throttle Plate
29	Gasket – Manifold Flange

*Not normally removed for service.

Disassembly

Disassembly consists of separating the carburetor into two basic groups: air intake and fuel bowl-throttle body and the disassembly of each of these groups. Use exploded illustration as a guide for disassembly and reassembly.

Cleaning and Inspection

Thoroughly clean all metal parts in solvent or Deepclene. Blow out all parts and channels with air pressure. Inspect for damage, excessive wear, burrs or warpage. **DO NOT CLEAN NON-METALLIC PARTS** in solvent or Deepclene.

NOTE: The following assembly instructions and the exploded illustration are generalized and include all parts possibly found in the carburetor at this time. Therefore, all of the parts shown and mentioned may not be included in the particular assembly being worked on.

Assembly of Air Intake

1. Drive channel plug (50) into vacuum channel flush with surface.
2. Drive cup plug (4) into end of choke shaft hole opposite choke lever.
3. Insert choke shaft (53) with milled flat toward top.

Item	Description
30	Plate – Throttle
31*	Welch Plug – Vacuum Spark
32*	Tube – Vacuum Spark
33	Seal – Throttle Shaft
34	Lever & Shaft – Throttle
35	Screw – Idle Stop
36*	Plug – Throttle Body
37	Gasket – Pump Diaphragm
38	Protector – Diaphragm
39	Spring – Accelerator Pump
40	Cover – Accelerator Pump
41	Screw – Pump Cover, 4 Required
42*	Assembly – Check Valve
43	Ball – Pump Discharge
44*	Tube – Well
45	Weight – Pump Ball
46	Spring – Pump Weight
47	Jet Assembly – Accelerator
48	Washer – Accelerator Jet
49*	Tube – Idle Jet
50*	Plug – Vacuum Channel
51	Screw – Choke Cable
52	Screw – Choke Swivel
53	Lever & Shaft – Choke
54	O-Ring
55	Washer
56	Washer
57	Pump Spacer (Optional)
58	Washer

4. Install choke plate (2) in air intake and start screws (1). Note that edges are beveled to fit against wall then closed. On plates including poppet valve, the spring should face the top. Hold choke plate closed with finger and tighten screws.
5. Turn air intake upside down and insert vacuum power piston (6) into cylinder, making sure it will move freely. Hold in place and stake casting with punch at three points to retain piston assembly.
6. Press well filler tube (7) into casting to shoulder. Do not bend or distort.
7. Press idle tube (49) into casting with rolled down orifice into casting until the bottom end is 31.8 mm (1.25 inches) from the cast surface. Do not bend or distort.

Assembly of Fuel Bowl

1. Install the following parts as needed (not normally removed for service):
 - a. Cup plug (17) in shaft hole flush
 - b. Fuel channel plug (23) flush
 - c. Welch plug (24) over idle port
 - d. Idle channel plug (25) flush

ZENITH MODEL #33 CARBURETOR (Continued)

- e. Welch plug (31) over spark vacuum port
 - f. Spark vacuum tube (32) to approximately 14 mm (9/16 inch) from casting
 - g. Throttle body plug (36) flush
 - h. Pump check valve (42) flush using tool C151-53.
 - i. Well tube (44) making sure that end openings align with notch in casting at top and fuel channel at bottom.
2. Slide seal (33) over throttle shaft with lip toward lever and install shaft in body.
 3. Back out throttle stop screw (35) and pace body on bench with mounting flange up.
 4. With milled flat up, install throttle plate (30) with short side toward idle port and start screws (28). Make sure beveled sides of plate are next to throttle body bore. Tap the plate lightly (plate held closed) to center it and tighten screws.
 5. While holding throttle closed, screw idle stop screw (35) in until it touches the casting, then screw in an additional 3/4 turn.
 6. Install idle needle (27) washer (56) and spring (26) and screw in to gently touch the seat. Back screw out approximately one turn.
 7. Install power jet valve (14) using C161-9 wrench. No gasket required.
 8. Install main jet (22) and seat firmly with screwdriver. No gasket required.
 9. Install main jet plug (20) and washer (21) and tighten securely. If main jet adjustment or solenoid shutoff are used, install in place of plug.
 10. Turn body right side up. Insert float axle (13) into holes in float (12).
 11. Lower float axle and float into slot provided in body with the float needle sticking into the threaded opening.
 12. Install the fuel valve seat (19) and washer (18) making sure that the fuel valve enters the seat properly (the valve will enter the seat more easily if the float is held in the up position) and tighten securely.
 13. Insert float axle clip (11) in slot to bear against axle ends. Holding axle in place, raise float by applying light finger pressure to the float bracket. Float pontoons should be approximately level when the valve is seated. If not, bend tab to carefully adjust.
 14. Install O-ring (54) on venturi skirt and place venturi (10) into recess provided in body making sure that the nozzle (9) lines up with the notch in the fuel well.
 15. Place intake gasket (8) in position on body.
NOTE: If you have an older model unit with removable accelerator jet; after intake gasket (8) is in place, an additional washer (55) will be assembled over the accelerator jet tube (47) and set inside the large hole in the intake gasket (8) and on top of the smaller washer (48). Lower air intake carefully onto bowl and fasten securely and evenly using attaching screws (5).

16. Place accelerator pump diaphragm (37) in place on body with bagged section into cavity. Insert diaphragm protector (38) into end of spring (39) and install spring with protector against diaphragm.
17. Place cover (40) over spring and compress. Insert screws (41) and tighten evenly and securely.

NOTE: Pump spacer (57) will install into cover before assembly if required.

Automatic Choke Operation

When the engine is cranked, a rich mixture is delivered to the engine. When the engine starts, air movement into the carburetor causes the choke plate to open slightly against the thermostatic spring pressure. As the engine warms up the thermostatic coil unwinds and the choke plate gradually opens.

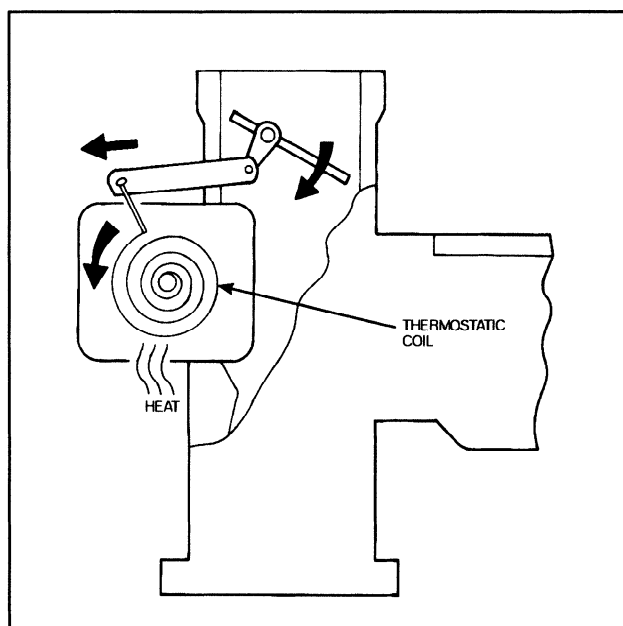

Although the thermostatic coil unwinds as the engine warms up, the actual unwinding of the coil is assisted by an electric heater.

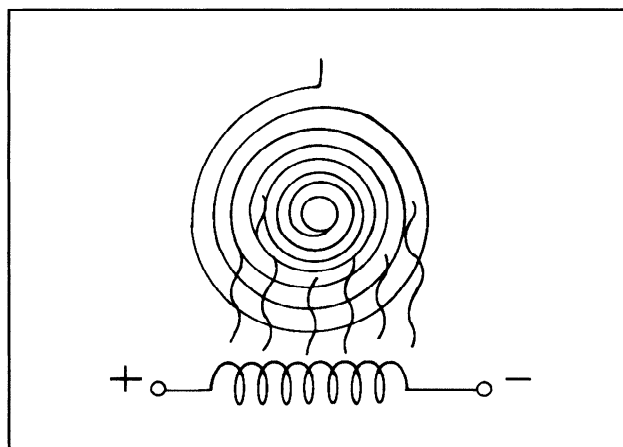

ZENITH MODEL #33 CARBURETOR (Continued)

When the temperature drops below a certain point a thermostatic switch closes and the heater circuit is complete. Electric current, supplied by circuit, now flows through the coil heater. Its electrical resistance to current flow generates the necessary heat.

Choke Pull-Off

After the engine is started, air flow into the carburetor will open the choke plate a small amount against the tension of the thermostatic coil. The choke plate will open this slight amount because it is mounted off center on the choke shaft.

This slight opening of the choke plate is necessary to prevent an overly rich mixture after the engine starts. Because the velocity of the air entering the carburetor will vary with engine speed, the choke plate is linked to a vacuum operated piston that provides a positive pull against the closing tension of the thermostatic coil.

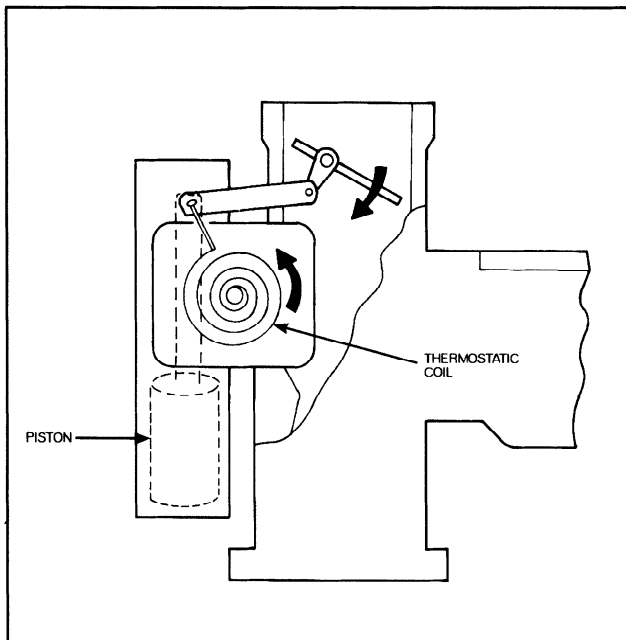

The action of the piston is called choke pull off, and its purpose is two-fold.

- It helps open the choke after the engine starts
- It controls the position of the choke plate depending on engine load.

When the throttle is opened to accelerate, the air/fuel mixture has to be enriched. The action of the accelerator pump provides momentary enrichment, but additional richness is required, since the engine is cold. This added richness is provided by the action of the pull off system.

The opening of the throttle valve causes a drop in intake manifold vacuum which is transmitted to the diaphragm or piston. With the lower vacuum signal, the choke coil is able to move the choke valve towards the closed position. The amount it is closed depends on how much vacuum drop occurs during acceleration.

Automatic Choke Setup Procedure

The automatic choke assembly contains a bimetallic (thermostatic) coil spring which regulates the choke plate opening at different temperatures, and a vacuum piston which regulates choke pull-off. The piston exerts a pull against the closing action of the thermostatic spring. This helps to open the choke after the engine starts, and controls the position of the choke plate depending on engine load.

Adjusting the Choke Pull-Off

1. Remove the choke housing cover.
2. Remove the cork insulation strip.
3. Remove the inner plate.
4. Position the sliding pin in the slip link slot away from the piston.
5. Place a 9.52 mm (0.375 inch) gage pin between the top of the choke plate and the inside of the air intake.

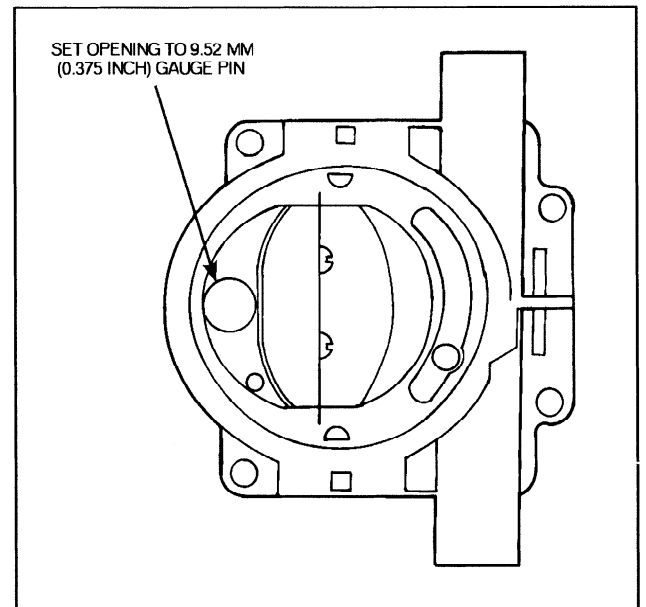

ZENITH MODEL #33 CARBURETOR (Continued)

- Adjust the stop screw until the slip link starts to move away from the pin.

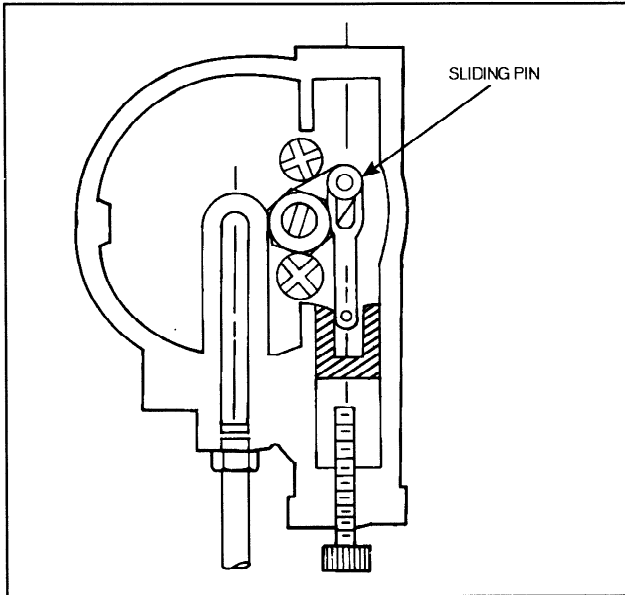

- Tighten the lock nut to 0.9-1.4 N•m (8-12 lb. in.) to limit the travel of the piston so that the choke plate is pulled to the gage dimension.
- Install the inner plate.
- Install the cork insulation strip.
- Install the choke housing cover.

Adjusting the Thermostatic Spring

- Manually open the choke plate by rotating the choke shaft.
- Allow the thermostatic spring (inside the choke assembly) to slowly close the choke plate. When the choke housing is at 21°C (70°F), the choke plate should be within 0.8 mm (1/32 inch) of, but not touching, the choke bore.

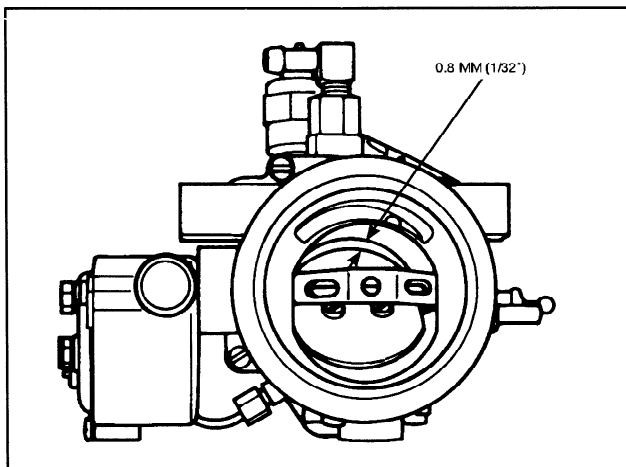

- If the choke plate does not meet this dimension, loosen the three cover plate screws to rotate the cover as necessary, and repeat steps 1 and 2.
- If the carburetor temperature is other than 21°C (70°F), make the following correction:
 - Set the choke plate as described in steps 2 and 3.
 - Readjust the cover plate to compensate for the deviation from 21°C (70°F). Each mark on the cover plate denotes a 2.8°C (5°F) change in the setting. For example, if the actual carburetor temperature is 27°C (80°F) when the choke plate is adjusted, rotate the cover two marks in the LEAN direction. Likewise, if the carburetor temperature is 10°C (50°F), rotate the cover four marks in the RICH direction.

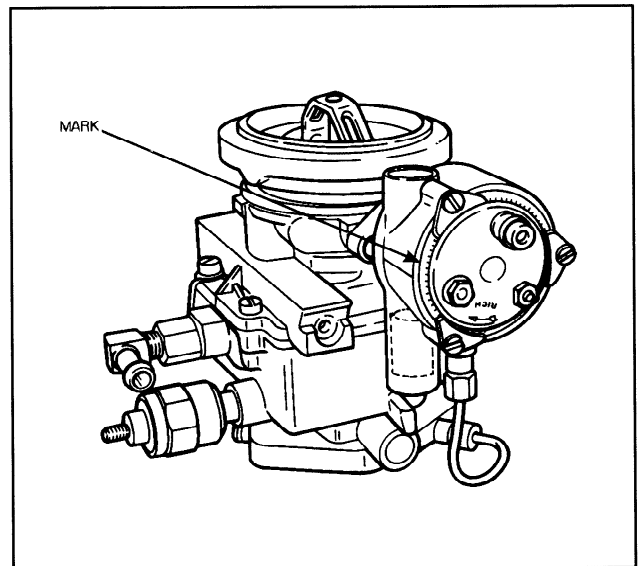

- Tighten the three cover screws.
- Check the rotation of the choke shaft to be sure there is no sticking or binding before installing the carburetor.

SECTION TITLE	PAGE	SECTION TITLE	PAGE
BASIC ENGINE	01-1	STARTING SYSTEM	05-1
IGNITION SYSTEM – DISTRIBUTORLESS	02-1	GOVERNOR	06-1
FUEL SYSTEM	03-1	COOLING SYSTEM	07-1
EMISSION CONTROL SYSTEM	03A-1	SPECIFICATIONS	08-1
CHARGING SYSTEM	04-1		

SECTION 03A — Emission Control System

SUBJECT	PAGE	SUBJECT	PAGE
DESCRIPTION AND OPERATION	03A-3	EGR System Gas Flow Test	03A-7
Exhaust Gas Recirculation (EGR) Valve	03A-3	Diaphragm Leak Test	03A-7
Crankcase Emission Control System	03A-6	EGR Valve Leakage Check	03A-8
DIAGNOSIS AND TESTING	03A-7	Testing for EGR Source Vacuum	03A-8
Symptoms of EGR System Malfunctions	03A-7	Testing the 2-Port PVS Valve	03A-8
Rough Idle	03A-7	REMOVAL AND INSTALLATION	03A-9
Surge, Stall, or Won't Start	03A-7		
Detonation (Spark Knock)	03A-7		
Poor Fuel Economy	03A-7		

BLANK

DESCRIPTION AND OPERATION

Exhaust Gas Recirculation (EGR) Valve

The exhaust gas recirculation (EGR) system feeds a controlled amount of exhaust gas back through the

cylinders to reduce the combustion temperature. This reduces the formation of an atmospheric pollutant known as "oxides of nitrogen" (NOx).

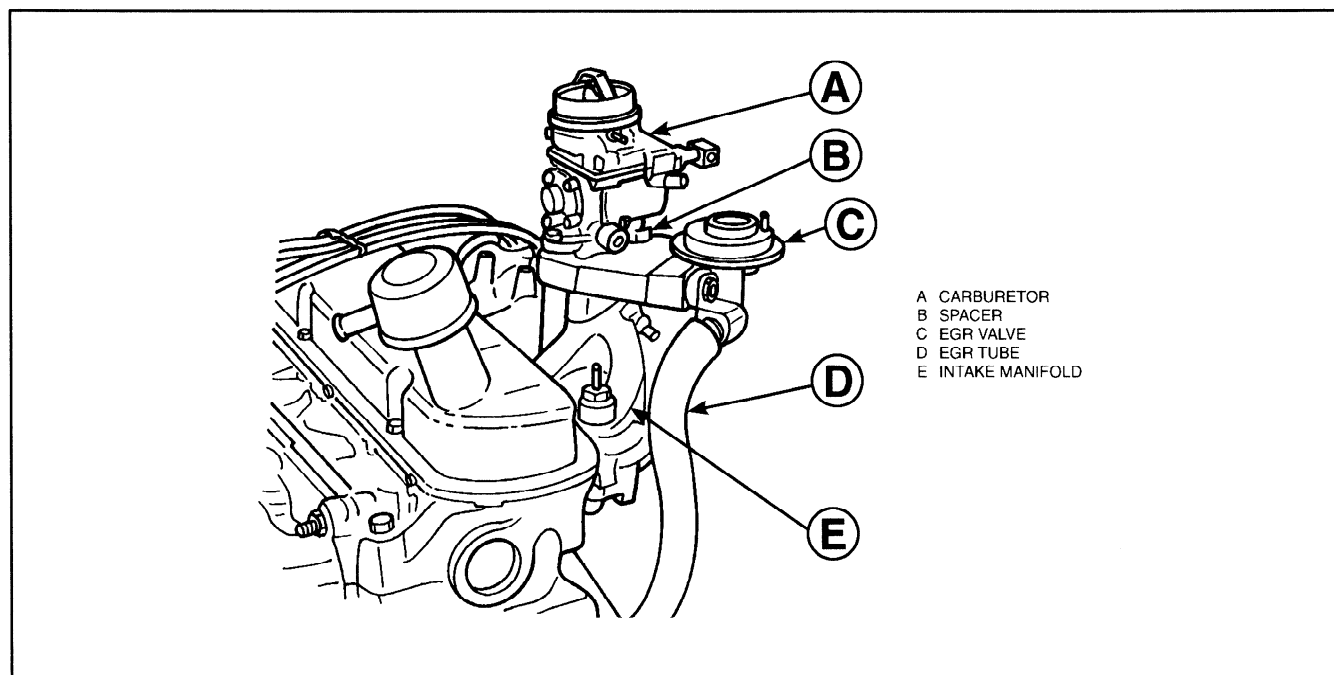

The EGR valve is a vacuum-operated flow-control valve. It is attached to the carburetor by an EGR valve adapter.

Between the EGR valve adapter and the carburetor is a spacer which has gaskets on both sides.

DESCRIPTION AND OPERATION (Continued)

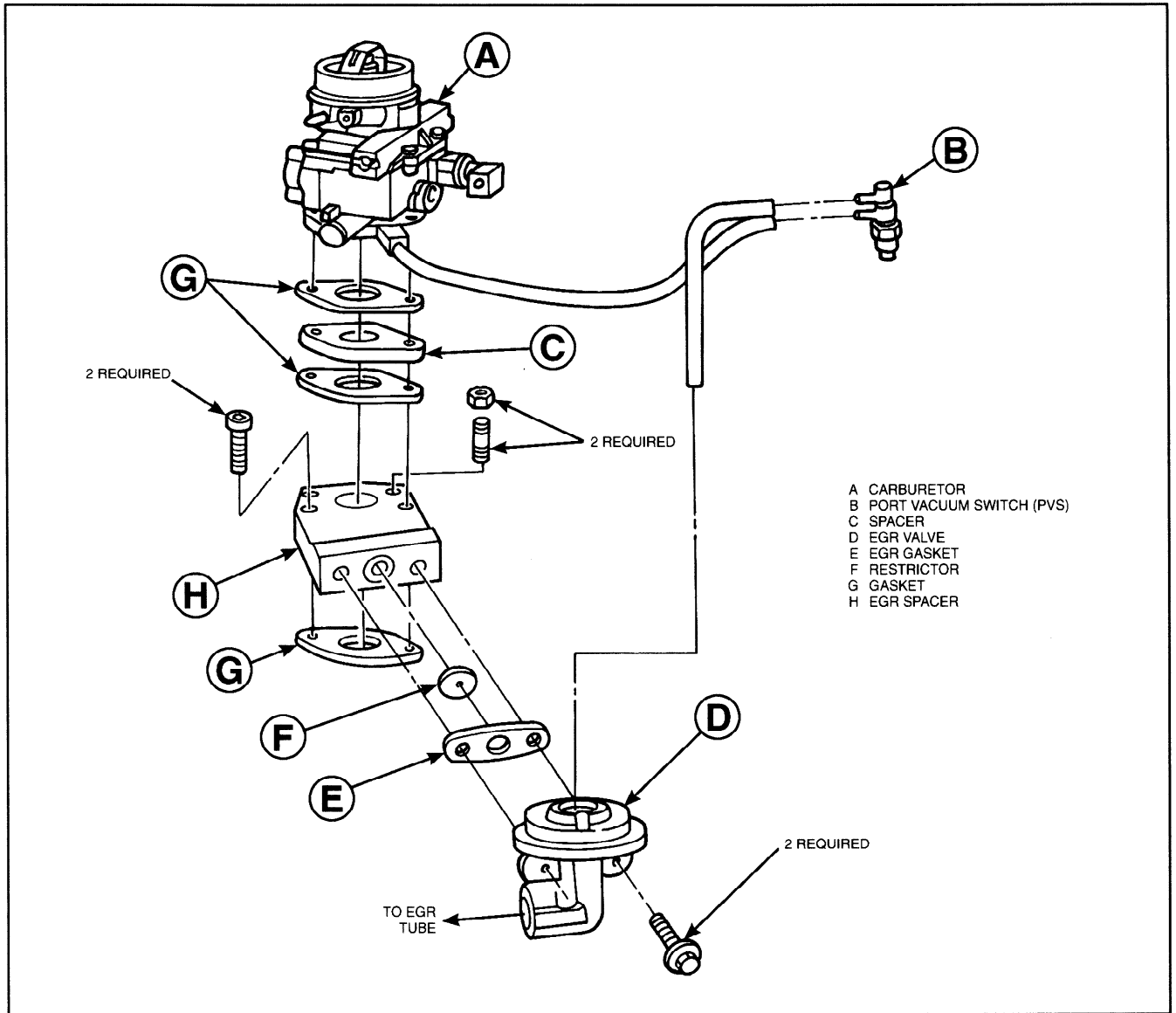

The EGR valve is operated by a vacuum signal from the carburetor, which actuates the valve diaphragm. As the vacuum increases sufficiently to overcome the diaphragm

spring, the valve is opened, allowing EGR flow. The amount of flow is dependent on the location of a tapered pintle, which is a direct result of the vacuum signal.

DESCRIPTION AND OPERATION (Continued)

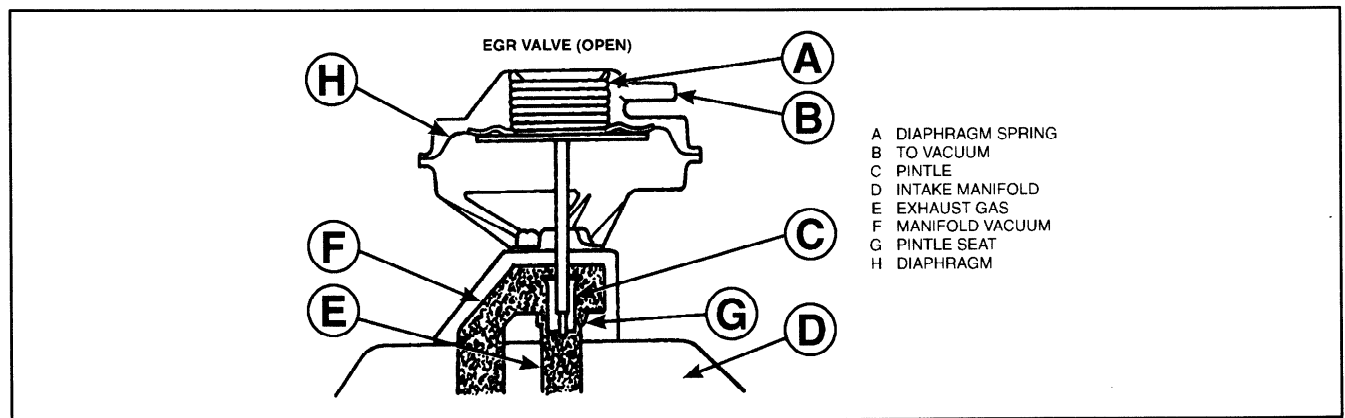
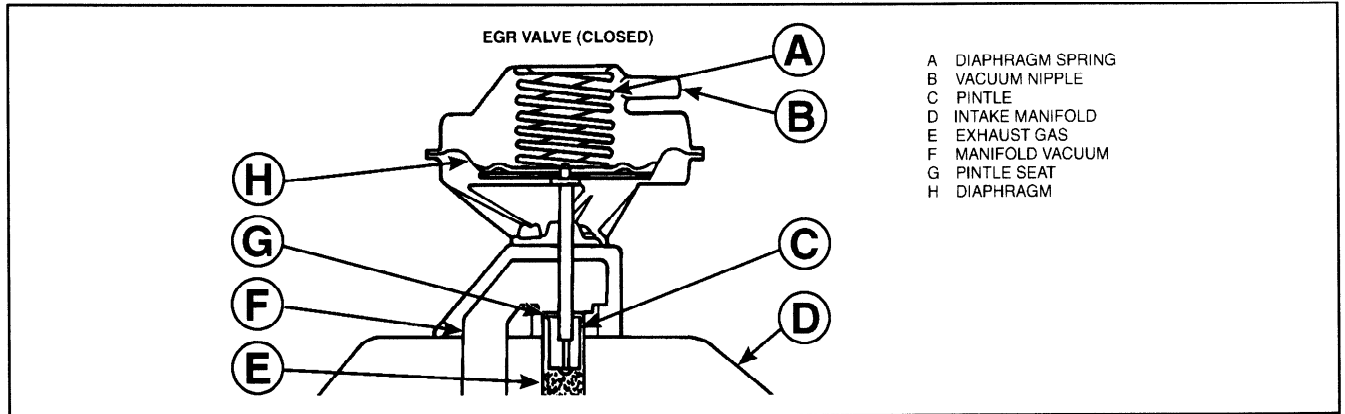

The EGR vacuum port is open to vacuum when the throttle plate is opened slightly (off idle). Vacuum is then available to the EGR control valve. Vacuum level decreases as the throttle plate opens.

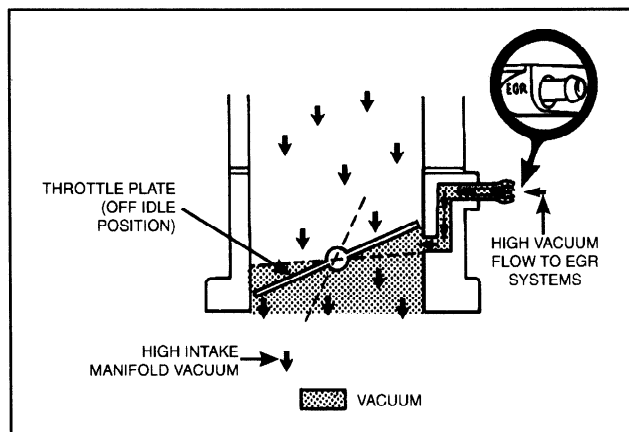

At closed throttle, the EGR port is blocked from vacuum. At wide open throttle, EGR vacuum is weak to zero and will cause the EGR valve to close for maximum engine power. Note that at idle (when EGR vacuum is off) the EGR system is least needed because NO_x formation is at a minimum.

Under certain circumstances, the EGR valve will usually be off. These include:

1. At idle, when the engine needs a richer mixture.
2. When the engine is cold.
3. When there is a heavy load (wide-open throttle).

At idle and at wide-open throttle, there is no vacuum at the EGR vacuum port. To control EGR at various engine temperatures, a port vacuum switch (PVS) is used.

DESCRIPTION AND OPERATION (Continued)

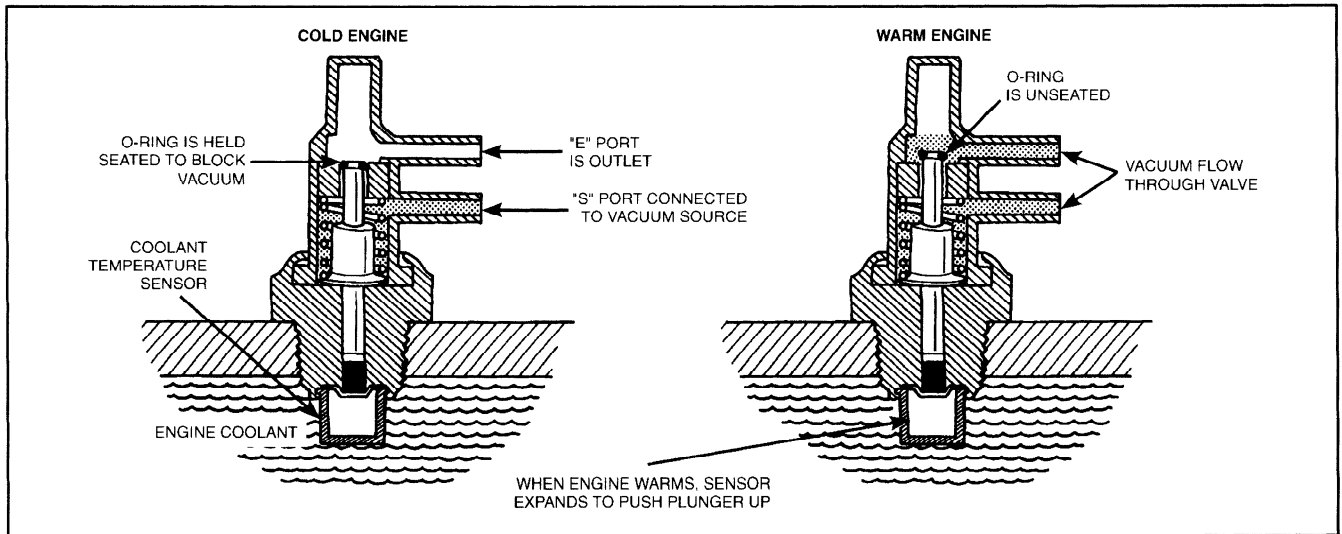

The two-port PVS senses engine coolant temperature so that it can cut off vacuum to the EGR valve when the engine is cold, and connect vacuum to the EGR valve when the engine is warm.

Crankcase Emission Control System

The Crankcase Emission Control System consists of an oil filler cap (including PCV valve) with two connecting hoses, one of which passes to the inlet manifold and the other to the air cleaner. The result is a closed ventilation system in which the fumes from the crankcase pass back via the inlet manifold into the cylinders for combustion.

DIAGNOSIS AND TESTING

Symptoms of EGR System Malfunctions

Many problems of poor engine performance are incorrectly diagnosed as being related to the EGR valve or EGR system. Therefore, it is important to know what engine symptoms **can** be EGR-related and how to test the system.

Rough Idle

This can be caused by an EGR valve stuck **open**, by dirt on the valve seat, or by loose mounting bolts. Loose mounting will cause a vacuum leak and a hissing noise. A stuck valve can be diagnosed by a functional test and by visual inspection.

Surge, Stall, or Won't Start

Can be caused by the valve stuck **open**.

Detonation (Spark Knock)

Any condition that prevents poor EGR gas flow can cause detonation. This includes a valve stuck closed, leaking valve diaphragm, restrictions in flow passages, EGR disconnected, or a problem in the vacuum source. On engines with high spark advance, detonation is serious enough to destroy an engine. Diagnose the condition by performing the tests in this section.

CAUTION: Improper use of leaded gasoline can plug up an EGR valve with deposits that restrict flow.

Poor Fuel Economy

This is an EGR condition only if it is related to detonation or some other symptom of restricted or zero EGR flow.

EGR System Gas Flow Test

The exhaust gas flow test must be made with the engine idling and hot. It tells you if the gas flow passages are open.

1. Remove the vacuum line from the valve diaphragm. Plug the line to prevent a vacuum leak or dirt entry.
2. Attach a hand vacuum pump to the valve diaphragm.
3. Apply 15 inches of vacuum to the valve, a little at a time.

If the gas flow is okay, the engine will begin to idle roughly at some point, or it may stall. If the idle doesn't change, there is a restricted passage in the valve or the spacer. Remove the valve for inspection. If the valve diaphragm fails to hold vacuum, install a new EGR valve.

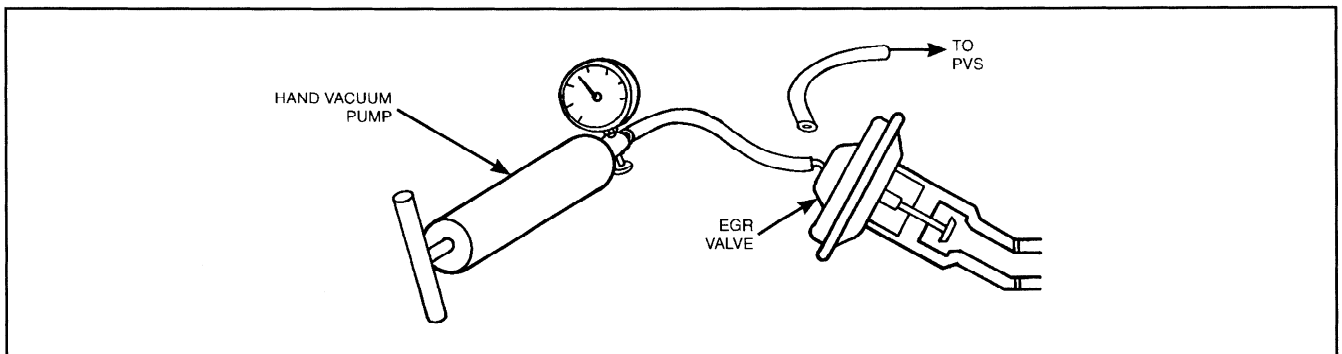

Diaphragm Leak Test

The diaphragm leak test can be performed with the engine off.

1. Attach a hand vacuum pump to the vacuum nipple of the EGR valve.
2. Apply eight inches of vacuum and trap (hold) it.

The diaphragm must hold 7-8 inches of vacuum for at least 30 seconds. If it holds vacuum, the diaphragm is okay. Proceed to the Source Vacuum test. If the diaphragm won't hold vacuum, replace the EGR valve.

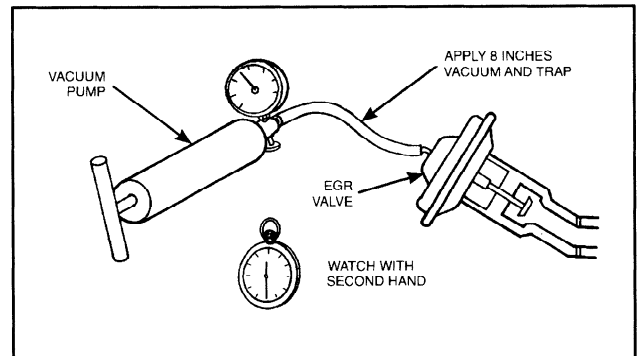

DIAGNOSIS AND TESTING (Continued)

EGR Valve Leakage Check

Perform this test if the engine stalls, idles roughly, or runs poorly.

1. Remove and cap the EGR valve vacuum hose. Start the engine. If the engine idle quality improves noticeably, double-check the vacuum hose routing because the valve may have a vacuum supply at idle.
2. If the engine idle quality does not improve, remove the EGR valve from the spacer. Block the EGR passages with a plate or install a known good EGR valve. Start the engine. If the idle quality is still bad, the problem is elsewhere. Reinstall the EGR valve. If the idle quality improves noticeably, the EGR valve has excessive leakage and should be replaced.

Testing for EGR Source Vacuum

Occasionally the EGR system may fail to operate because the vacuum port on the carburetor is plugged, or because of a vacuum leak. To test for source vacuum:

1. Remove the EGR supply vacuum hose from its connection at the carburetor.
2. Attach a vacuum gauge to the source.
3. Start the engine and watch the gauge as you momentarily accelerate to half throttle 3000 rpm maximum). The vacuum should rise at off-idle, decrease at half throttle, and go to zero at closed throttle.

If the source vacuum is okay, test the PVS and inspect the hoses. If the source vacuum is not okay, check for an obstruction in the carburetor or for a vacuum leak caused by loose mounting.

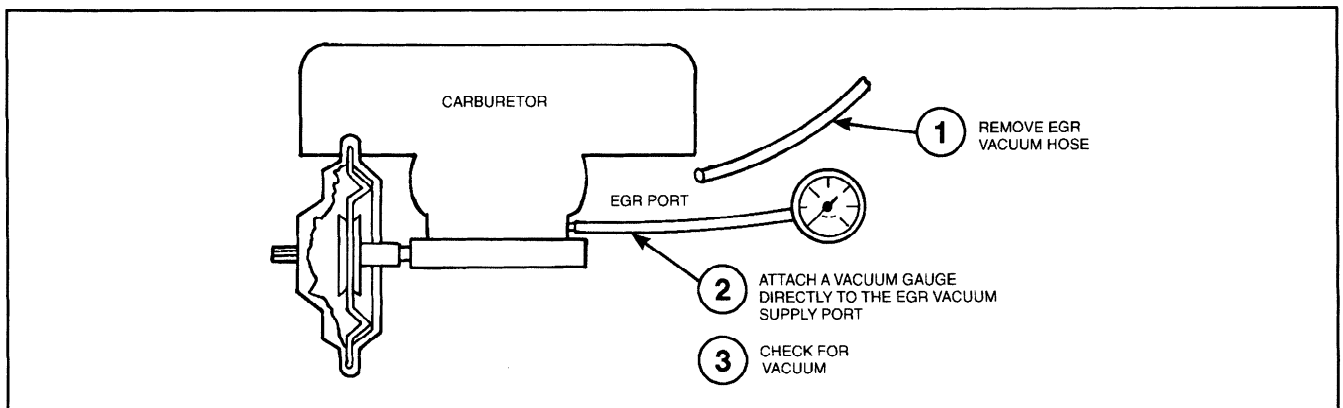

Testing the 2-Port PVS Valve

The 2-port PVS valve is okay if it blocks vacuum from the EGR valve when the engine is cold and allows a vacuum to get to the valve when the engine is hot.

WARNING: LET THE ENGINE COOL AND RELEASE COOLING SYSTEM PRESSURE BEFORE REMOVING THE VALVE, OR YOU COULD BE BURNED. IT ALSO MAY BE NECESSARY TO DRAIN OUT SOME OF THE COOLANT.

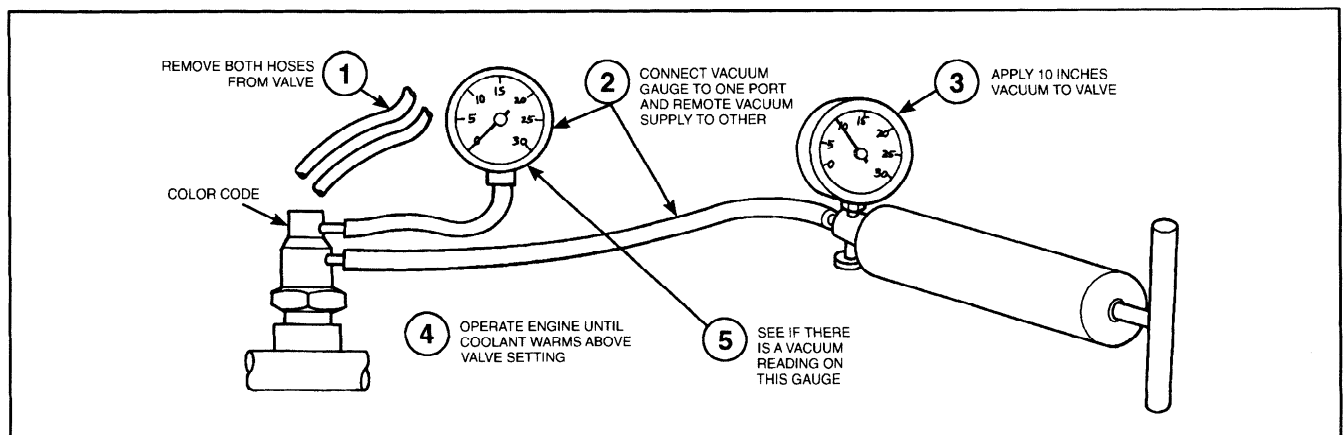

1. Remove both hoses from the PVS valve.
2. Connect a vacuum gauge to one port of the PVS valve and connect a vacuum pump to the other port.
3. Apply 10 inches of vacuum to the PVS valve.
4. Run the engine until the coolant is warmer than the PVS valve setting. PVS valves are color coded. This engine has a black PVS valve that opens at 38°C (100°F).
5. See if there is a vacuum reading on the gauge that is connected directly to the PVS valve.

There should be a vacuum reading on the gauge. If there is no vacuum, replace the PVS valve.

REMOVAL AND INSTALLATION

Removal

1. Remove the vacuum hose that goes to the PVS valve.
2. Remove the EGR hose.
3. Remove the two EGR valve mounting bolts.
4. Remove the EGR valve gasket.
5. Remove the EGR restrictor.

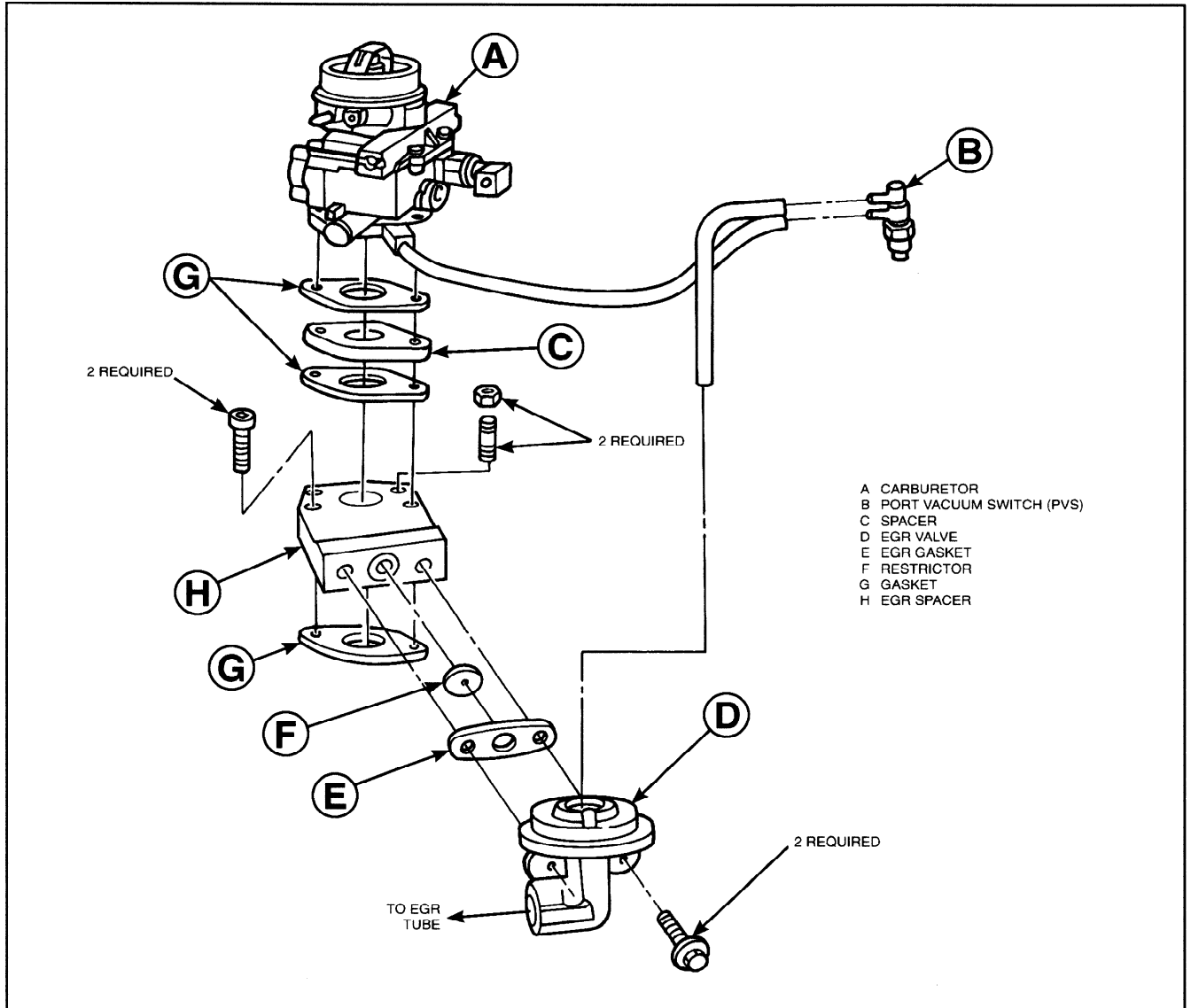

Installation

1. Seat the EGR restrictor into the spacer block. A small amount of grease may be applied to the EGR restrictor prior to installation. This will ensure that the EGR restrictor does not become dislodged during the installation of the EGR valve gasket and the EGR valve. Do not allow grease to block the hole in the EGR restrictor.
2. Install the EGR valve gasket.
3. Install the EGR valve.
4. Install the two EGR valve mounting bolts. Tighten to 16-20 N•m (12-15 ft. lbs.).
5. Install the EGR hose. Tighten to 34-47 N•m (25-35 ft. lbs.).
6. Attach the vacuum hose that comes from the PVS valve.

SECTION TITLE	PAGE	SECTION TITLE	PAGE
BASIC ENGINE	01-1	STARTING SYSTEM	05-1
IGNITION SYSTEM – DISTRIBUTORLESS	02-1	GOVERNOR	06-1
FUEL SYSTEM	03-1	COOLING SYSTEM	07-1
EMISSION CONTROL SYSTEM	03A-1	SPECIFICATIONS	08-1
CHARGING SYSTEM	04-1		

SECTION 04 — Charging System

SUBJECT	PAGE	SUBJECT	PAGE
DESCRIPTION AND OPERATION	04-3	Regulator Input Test	04-9
Generator	04-3	Generator Brush Check	04-10
DIAGNOSIS AND TESTING	04-5	Field Ground and Open Tests	04-10
Preliminary Information	04-5	Field Voltage Test	04-10
Isolating the Problem	04-5	Overcharging	04-11
Battery Testing	04-5	Generator Disassembly	04-11
Capacity Test	04-5	ADJUSTMENTS	04-12
System Connections	04-6	Belt Adjustments	04-12
Generator Connections	04-6	REMOVAL AND INSTALLATION	04-13
Electrical Testing Precautions	04-6	OVERHAUL	04-14
Output Voltage Test	04-6	Disassembly	04-14
Regulator Bypass Test	04-7	Releasing Front Bearing Retainer	04-14
Key-Off Check	04-7	Front or Rear Bearing Removal	04-14
Regulator Sense Voltage	04-7	Front Bearing Installation	04-15
External Circuit Tests	04-8	Pressing Front Bearing Onto Shaft	04-15
Field Voltage Test	04-8	Assembly	04-15
Initial Excitation Circuits	04-9	Output Voltage Test	04-16

BLANK

DESCRIPTION AND OPERATION

Generator

The generator charging system is a negative ground system, and consists of an generator, a regulator, a charge indicator, a storage battery, and associated wiring.

The present VSG range uses a Prestolite 37-amp or 51-amp generator. These units have a self-contained regulator mounted directly to the generator case. The generator is belt driven from the engine. Current is supplied

from the generator-regulator system to the rotating field of the generator through two brushes to two slip rings.

The generator produces power in the form of alternating current. The alternating current is rectified to direct current by six diodes. The generator regulator automatically adjusts the generator field current to maintain the generator output voltage within prescribed limits to correctly charge the battery.

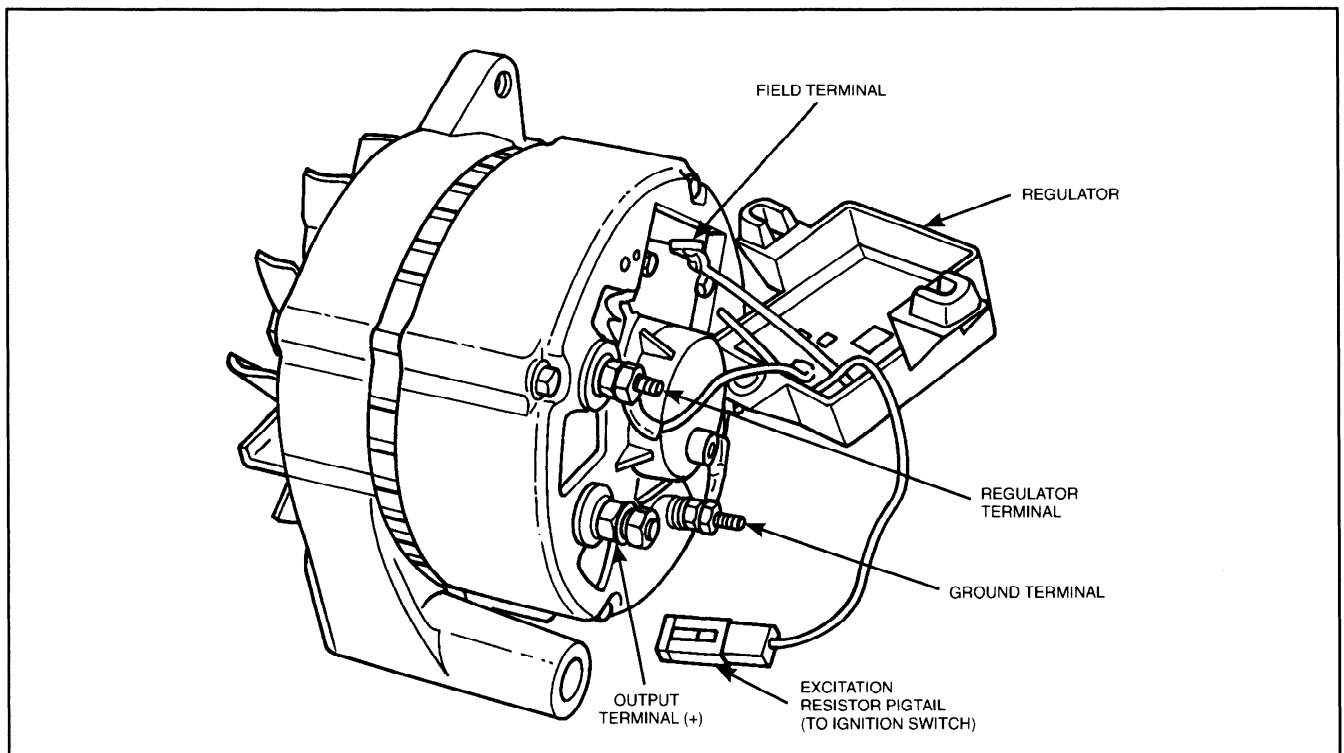
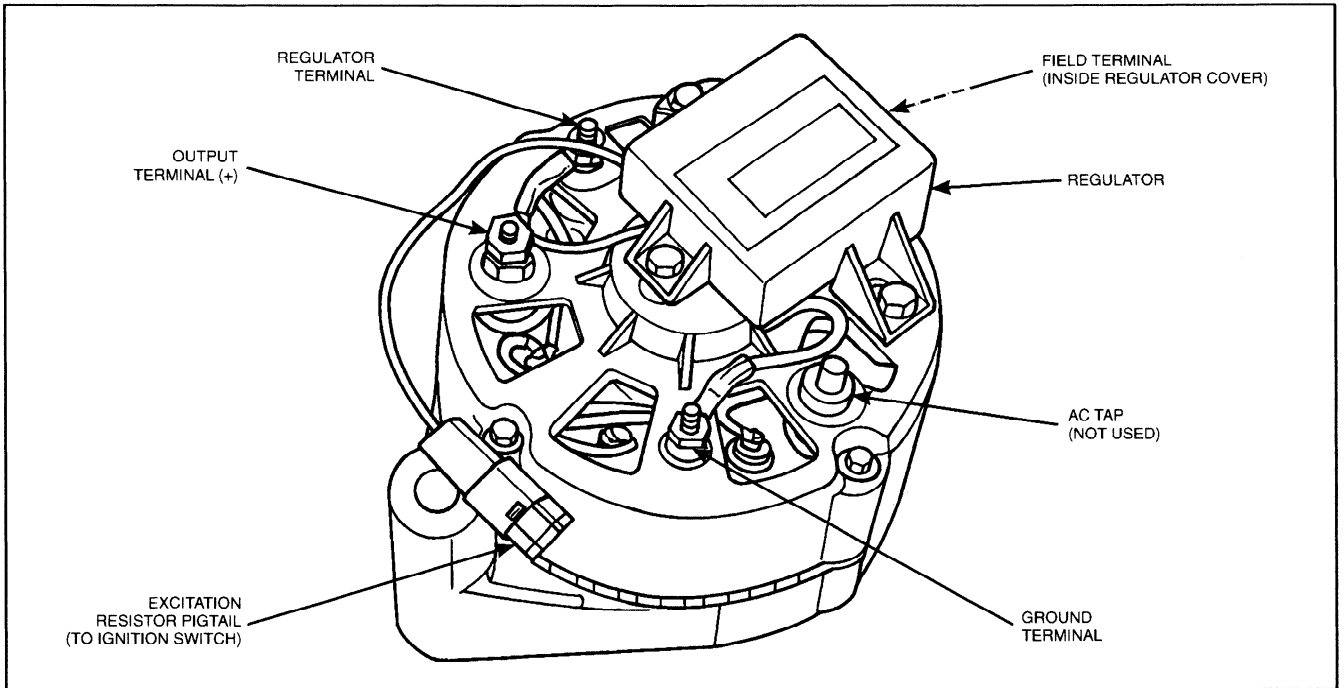

DESCRIPTION AND OPERATION (Continued)

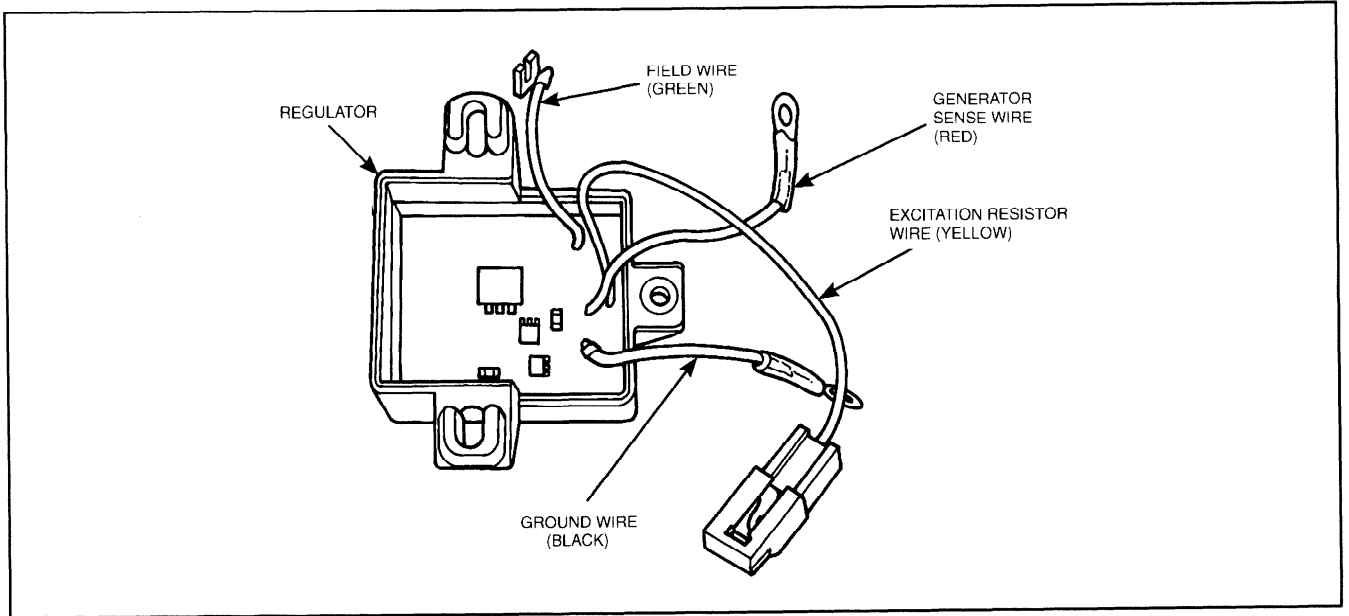

DIAGNOSIS AND TESTING

Preliminary Information

Before performing charging system tests on the engine, note the complaint such as: slow cranking, battery dead or using an excessive amount of water, top of battery wet, ammeter shows charge at all times and/or no charge, generator warning lamp does not come on and/or never goes out, voltmeter shows above or below open circuit nominal voltage. This information will aid in isolating the part of the system causing the symptom.

Next, visually inspect as follows:

1. Check battery posts and battery cable terminals for clean and tight connections. Remove the battery cables (if corroded), clean and install them securely.
2. Check for clean and tight wiring connections at the generator, regulator and engine. Inspect for evidence of arcing.
3. Check the generator belt tension using belt tension gauge T63L-8620-A, Model 210019 or equivalent and tighten to specification (if necessary).

Isolating the Problem

Battery, starting system, and light systems problems can be caused by poor charging system performance. It is also possible to suspect the charging system because of an overload in another area of the electrical system.

To avoid guesswork, it is necessary to isolate the battery, the charging system, and the electrical circuits to correctly identify the area where the difficulty lies. The best method to do this is to check the battery first before any electrical system diagnosis. The battery must be in proper state of charge. The battery must be operating properly before the other areas of the electrical system can perform normally.

Battery Testing

WARNING: KEEP BATTERIES OUT OF REACH OF CHILDREN. BATTERIES CONTAIN SULFURIC ACID. AVOID CONTACT WITH SKIN, EYES OR CLOTHING. ALSO, SHIELD YOUR EYES WHEN WORKING NEAR THE BATTERY TO PROTECT AGAINST POSSIBLE SPLASHING OF THE ACID SOLUTION. IN CASE OF ACID CONTACT WITH SKIN, EYES, OR CLOTHING, FLUSH IMMEDIATELY WITH WATER FOR A MINIMUM OF 15 MINUTES. IF ACID IS SWALLOWED, DRINK LARGE QUANTITIES OF MILK OR WATER, FOLLOWED BY MILK OF MAGNESIA, A BEATEN EGG OR VEGETABLE OIL. CALL A PHYSICIAN IMMEDIATELY. HYDROGEN AND OXYGEN GASES ARE PRODUCED DURING NORMAL BATTERY OPERATION. THIS GAS MIXTURE CAN EXPLODE IF FLAMES, SPARKS OR LIGHTED TOBACCO ARE BROUGHT NEAR THE BATTERY. WHEN CHARGING OR USING A BATTERY IN AN ENCLOSED SPACE, ALWAYS PROVIDE VENTILATION AND SHIELD YOUR EYES.

WARNING: BATTERIES ARE HEAVY, WEIGHING 30 LBS. OR MORE. LIFT THEM WITH YOUR LEGS RATHER THAN YOUR BACK TO PREVENT MUSCLE STRAINS, AND BE CAREFUL NOT TO DROP THEM (POSSIBLE BREAKAGE) OR TO SPILL THE CONTENTS (SULFURIC ACID).

CAUTION: 12-volt starting motors can be damaged beyond repair if connected to a 24-volt power supply (two 12-volt batteries in series, or a 24-volt motor-generator set), even when cranking loads are relatively light. Extensive starting motor damage is more likely if the starter is connected to a 24-volt supply while being subjected to prolonged heavy cranking loads such as attempting to start an engine in subzero temperature.

Tests are made on a battery to determine the state of charge and also its capacity or ability to crank an engine. The ultimate result of these tests is to show that the battery is good, needs recharging, or must be replaced.

Before attempting to test a battery, it is important to give it a thorough examination to determine if it has been damaged. Remove battery cable clamps, negative (-) terminal first. Check for dirty or corroded connections and loose battery posts. Remove hold downs and heat shields and inspect for a broken or cracked case or cover. If the battery is worn or damaged, if there is a loose or broken post, or if there is a cracked case or cover, replace the battery.

The battery capacity test should be run next to remove any surface charge prior to determining the state of charge of a maintenance free battery.

Capacity Test

A high rate discharge tester (Rotunda Battery-Starter Tester 02-0204) or equivalent in conjunction with a voltmeter is used for this test.

1. Turn the control knob on the Battery-Starter Tester to the "OFF" position.
2. Turn the voltmeter selector switch to the 20-volt position and test selector switch to "AMP".
3. Connect both positive test leads to the positive (+) battery post and both negative leads to the negative (-) battery post. The voltmeter clips must contact the battery posts and not the high-rate discharge tester clips. Unless this is done, the actual battery terminal voltage will not be indicated.
4. Turn the load control knob in a clockwise direction until the ammeter reaches the applicable discharge rate specified in the discharge rate table.
5. With the ammeter reading the required load for 15 seconds, note the voltmeter reading. Avoid leaving the high discharge load on the battery for periods longer than 15 seconds.

If the voltmeter reading is above the minimum specified in the table with the test equipment for that temperature, the battery has a good output capacity and will readily accept a charge, if required. Check the state of charge.

If the voltage reading obtained during the capacity test is below the minimum specified in the table, check the state of charge.

DIAGNOSIS AND TESTING (Continued)

BATTERY DISCHARGE RATES

Ampere Hours	Discharge Rate Amperes
45	190
53	200
63	260
68	235
71	235
85	240
90	310

TEMPERATURE CORRECTION CHART — ALL BATTERIES

Temperature		Minimum Acceptable Load Voltage
°C	°F	
21	70 (or above)	9.6
16	60	9.5
10	50	9.4
4	40	9.3
-1	30	9.1
-7	20	8.9
-12	10	8.7
-18	0	8.5

System Connections

Check that all charging system connections, cables, and wires are sound, clean, and tight. This includes:

- Battery cables
- Battery connections
- Starter solenoid connections
- Starter ground
- Regulator terminal connections
- Generator wiring harness

Generator Connections

1. Check all the harness connections to the generator. Make sure they are clean and tight.
2. Inspect the soldered connections to the output diode and the ground diode. These connections are visible through the ventilation holes in the rear housing of the generator.

Electrical Testing Precautions

Observe the following precautions to avoid permanent damage to the regulator or to the generator diodes:

1. Do not disconnect the generator output lead, the ground lead, or the battery cable while the engine is running.
2. Do not disconnect the generator field terminal or the regulator connection while the engine is running.

3. Do not short the generator field terminal or field lead to ground.
4. Disconnect the battery ground terminal before removing the generator or the generator brush holder assembly.
5. Never reverse polarity when charging or replacing the battery.

Output Voltage Test

Perform this test if the trouble symptom is a warning light indication while running, or a no-voltage indication on the voltmeter. This test will check the generator output to verify that the problem is in the charging system and not in the instrument circuit. If the regulator is hot, do not perform this test until the regulator has cooled down. The regulator will respond to, and regulate at, a lower voltage as the temperature rises. This offsets the tendency toward battery overcharging in warm weather. This built-in temperature compensation reduces generator output by about one volt per 55°C (100°F) temperature rise.

1. Key OFF.
2. Check the voltage at the generator output terminal. It should be battery voltage.
3. Start the engine.
4. With the engine running at 1000 to 1200 rpm, check the voltage at the generator output terminal. The voltage should rise to 13.6 to 14.4 volts as soon as the starting discharge has been restored.

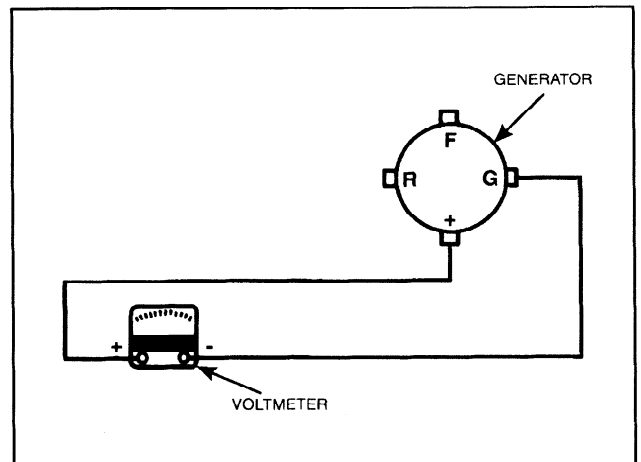

5. After the voltage stabilizes, turn on any accessories one by one while observing the output voltage. If it stays above battery voltage under load, but the warning light is on, or if the voltmeter indicates no voltage, the cause may be a blown fuse feeding the instrument circuit.

DIAGNOSIS AND TESTING (Continued)

Regulator Bypass Test

Perform this test if the Output Voltage Test indicates less than 13.6 volts at light load.

1. Key OFF.
2. Disconnect the field lead from the "F" terminal.
3. Connect a jumper from the "F" terminal to the "R" terminal.
4. Start the engine.

CAUTION: Be sure to keep the rpm low, as an unregulated generator can produce voltage high enough to cause damage.

5. With the engine running at idle, check the output voltage.

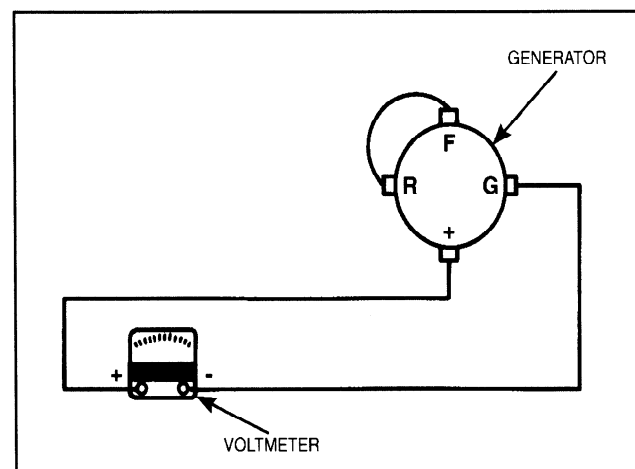

- If the output voltage is still low, the problem is in the generator.
- If the output voltage rises above 13.6 volts with the regulator bypassed, check the regulator circuit for low output (although the problem may still be partly or entirely in the generator). Possible generator problems include:
 - Defective output or field diodes.
 - Excess resistance in the field circuit, which includes the regulator.
 - Excess resistance in the charging circuit external to the generator.

Key-Off Check

1. Key OFF.
2. Remove the jumper between the "R" and "F" terminals, if present.
3. Connect the field lead to the "F" terminal, if it is not already corrected.
4. Check the voltage at the "R" terminal. If any voltage is present, it indicates a shorted output diode or diodes. This causes undercharging and also allows the battery to discharge through the regulator and field with the engine stopped.

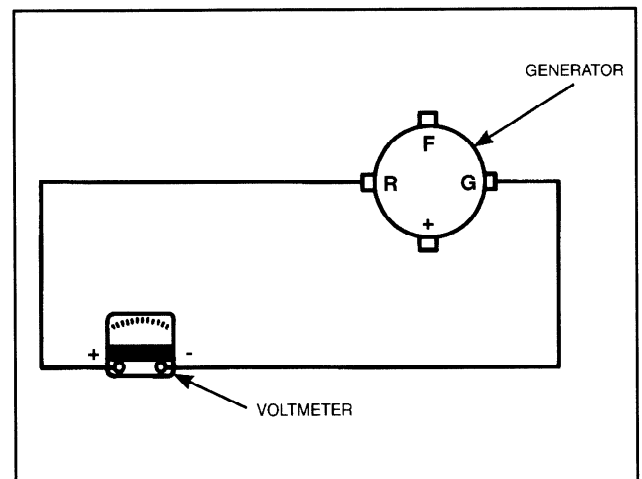

Regulator Sense Voltage

1. Start the engine.
2. With the engine running at 1000 to 1200 rpm, check the voltage from the "O" terminal to ground.

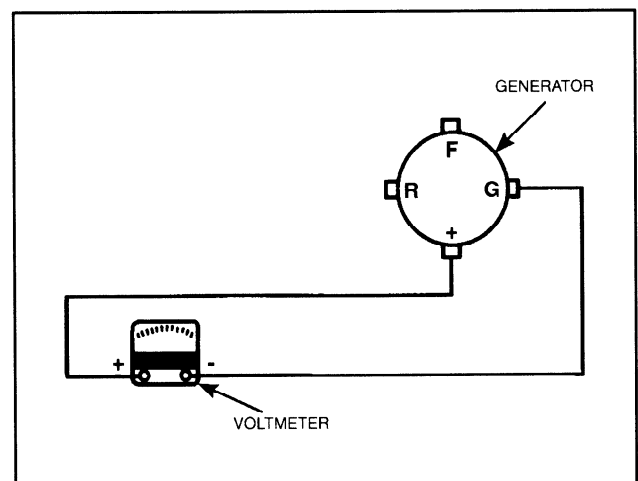

DIAGNOSIS AND TESTING (Continued)

- With the engine running at 1000 to 1200 rpm, check the voltage from the "R" terminal to ground.

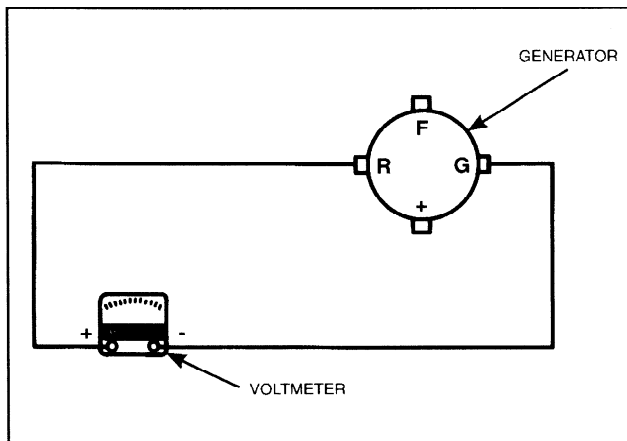

Even if the output voltage is low, the "R" terminal voltage should be within 0.5 volt of the "O" terminal voltage. If the "R" terminal voltage is higher than the output voltage, it indicates an open diode or diodes, and the higher "R" voltage would signal the regulator to reduce output before normal charging voltage could be built up. This causes an undercharging condition.

If the voltage at the "R" terminal is more than 0.5 volt lower than the output voltage, one or more of the field diodes is defective. In this condition, the regulator would normally increase the generator output to bring the sense voltage up to the regulating value, and an overcharging condition would result.

- Continue with External Circuit Tests.

External Circuit Tests

This test checks the circuit between the generator and the battery by measuring the voltage from each battery terminal to ground.

- With the engine running at 1000 to 1200 rpm, measure the voltage from the positive (+) battery terminal to ground. Voltage at the positive (+) terminal should be the same as the generator output voltage. If it is lower by more than 0.2 volt, excess resistance is present in the generator output lead or in the battery positive cable or connections. Check for wire or cable damage, or for loose or dirty connections.
- Measure the voltage from the battery negative (-) terminal to ground. It should be zero. If it is more than

0.2 volt, check the ground circuit. The following connections must be clean and tight:

- Generator mounting bolts
- Generator and engine mounting surfaces
- Ground cable connections to the engine and battery

Field Voltage Test

This test checks for initial excitation voltage at the "F" terminal. Perform this test if the output voltage did not rise above battery voltage in the output voltage test, but did rise with the regulator bypassed.

- Make sure the field lead is connected.
- Key ON.
- Measure the field voltage by carefully probing the "F" terminal.

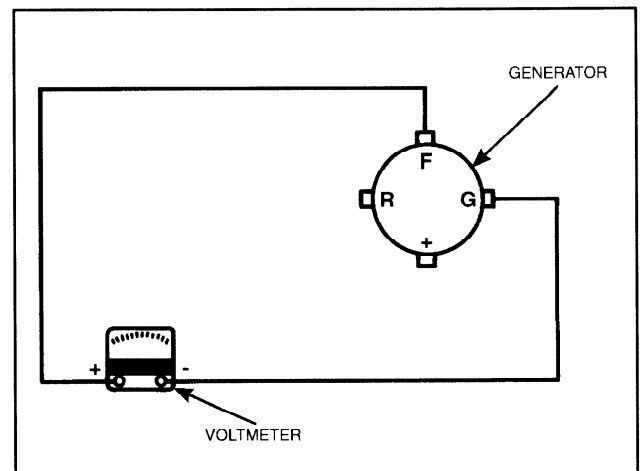

CAUTION: To avoid grounding the field and causing component damage, use a taped probe or connect the field lead through a jumper to provide meter probe access to the terminal.

A reading of 1.5 to 3.0 volts is normal. A zero-volt reading indicates an open in the initial excitation circuit, either in the regulator or in the circuit between the battery and the regulator.

If battery voltage appears at the "F" terminal, an open is present in the field circuit, either in the coil or in the brushes. The meaning of voltage readings between these extremes depends on the specific equipment being tested.

DIAGNOSIS AND TESTING (Continued)

Initial Excitation Circuits

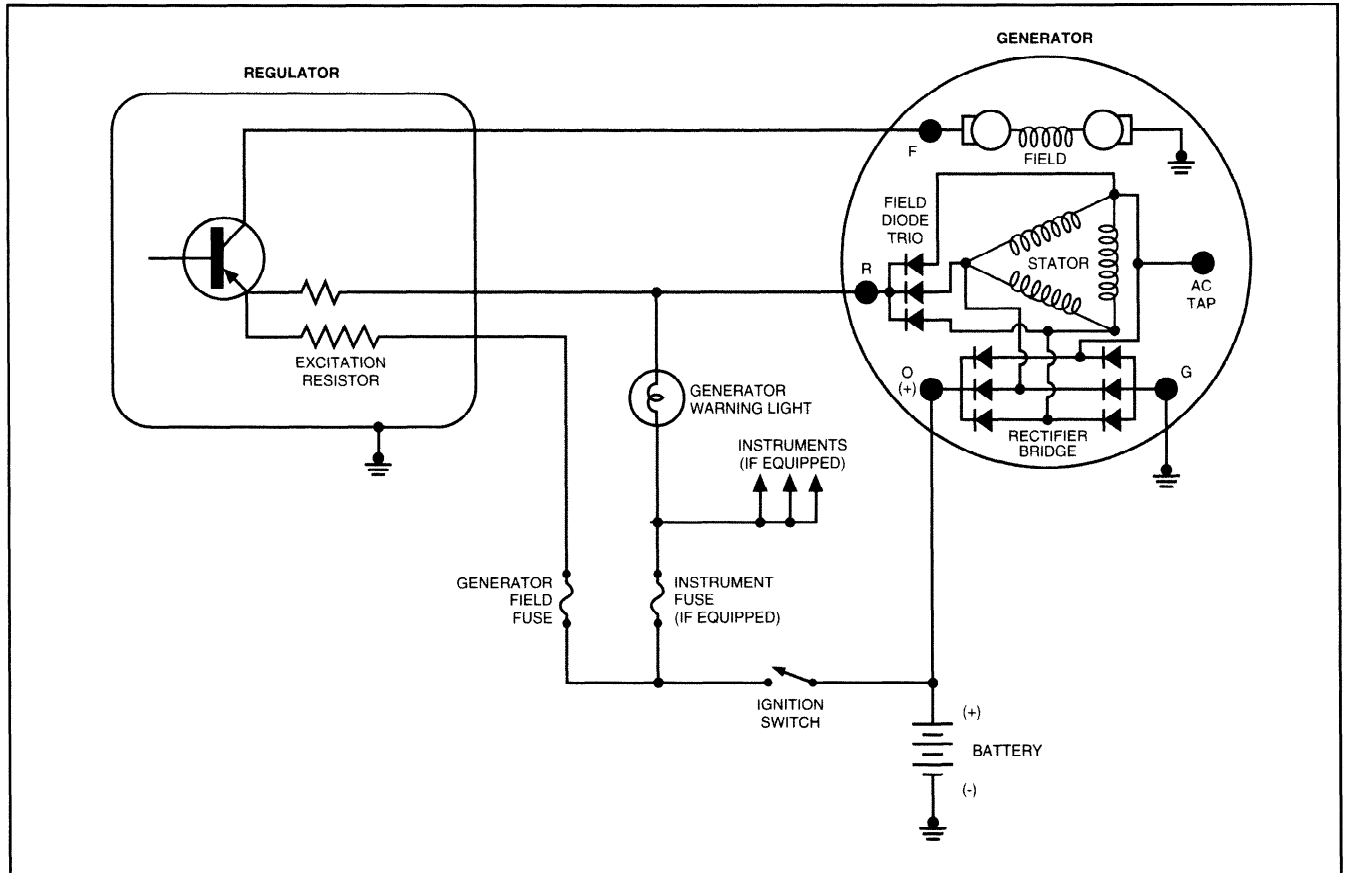

Initial excitation voltage reaches the field terminal through an excitation lead from the ignition switch to the regulator, and an excitation resistor inside the regulator. If the circuit is equipped with a voltmeter, this is the only path. If the circuit is equipped with a generator warning light, the warning light provides an alternate path in parallel with the excitation resistor. This excitation function of the warning light is an incidental result of its being positioned in the circuit so as to compare battery and output voltages, but it is important because it can mask an open in the excitation circuit.

Normally, initial excitation current is drawn through both paths, but either one will pass sufficient current if the other is open. If the excitation resistor is open, or higher in value than it should be, there will still be excitation current to magnetize the field at startup, but the voltage at the field terminal will be lower because of the larger voltage drop through the increased resistance. Likewise, if the warning light bulb is burned out, the excitation resistor will provide field current, but also at reduced voltage. A burned-out bulb is easily detected if it fails to light when the key is turned ON, and the other warning lights and gauges respond normally.

Regulator Input Test

This test measures excitation supply voltage to the regulator. Perform this test if the field terminal voltage is less than 1.5 volts.

1. Key ON.
2. Carefully probe the yellow wire terminal in the pigtail connector for the regulator excitation lead. Battery voltage should be present.

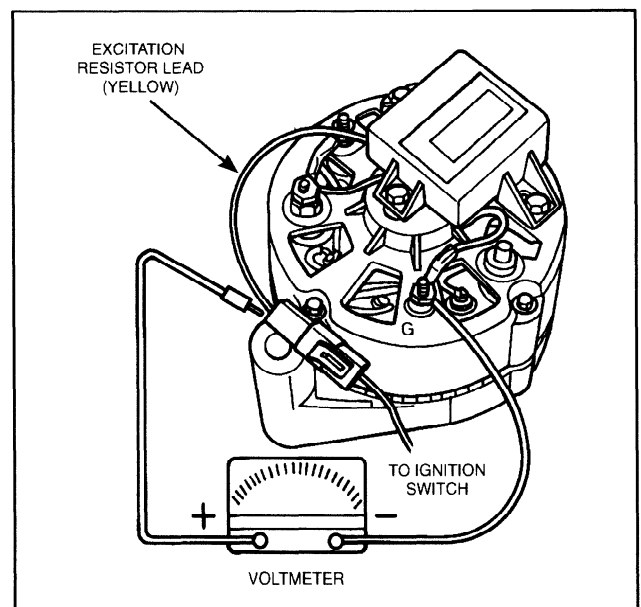

DIAGNOSIS AND TESTING (Continued)

3. If battery voltage is not present, check the circuit from the ignition switch, through the alternator field fuse (if so equipped) to the pigtail connector for the regulator excitation lead. If battery voltage is present at the yellow regulator lead, but the regulator output is low, replace the regulator.

Generator Brush Check

If the field terminal voltage is more than 3.0 volts, undercharging may be caused by high resistance in the generator field circuit, even though generator output was increased in the regulator bypass test. Even if field circuit resistance is normal, it may be a combination of low field coil resistance (due to a partially shorted coil) and high brush resistance.

1. Disconnect the battery ground cable at the battery.
2. Remove the regulator housing.
3. Remove the field wire from the field terminal.
4. Remove the generator brush holder assembly.

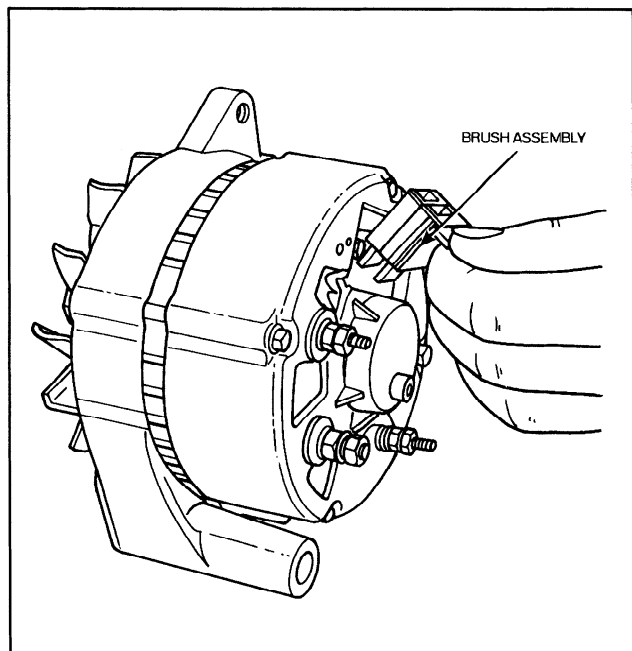

5. Inspect the brushes for abnormal wear, damage, dirty contact surfaces, or sticky movement.
6. Clean and free up the brushes or replace the assembly.
7. While the brush holder is out, release belt tension to allow free rotation of the rotor and clean the slip rings with crocus cloth or fine abrasive.

Field Ground and Open Tests

This test uses an ohmmeter to check for opens or shorts to ground in the field.

1. Touch the meter probes to either of the slip rings and to ground. If the meter shows continuity or low resistance, there is a grounded condition. In that case, replace the rotor.

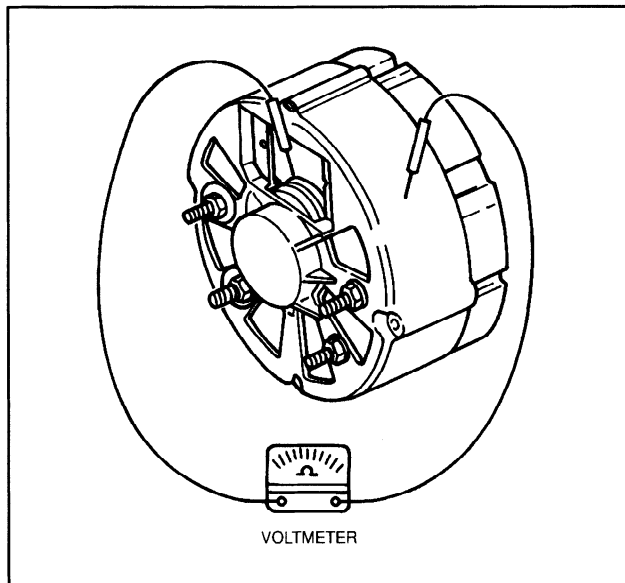

2. Measure the resistance from one slip ring to the other. Field coil resistance should be 4 to 5 ohms. If the ohmmeter indicates a high resistance between the slip rings, the field is partially open. In that case, replace the rotor.

Field Voltage Test

With the slip rings clean, and known good brushes installed, repeat the field excitation voltage test at the "F" terminal.

1. Key ON.
2. Release belt tension to allow the rotor to spin freely.
3. While spinning the rotor by hand to assure good brush contact, probe the "F" terminal and observe the voltage. If it still does not fall within the 1.5 to 3.0 volt range, the field coil resistance is incorrect. In that case, replace the rotor.

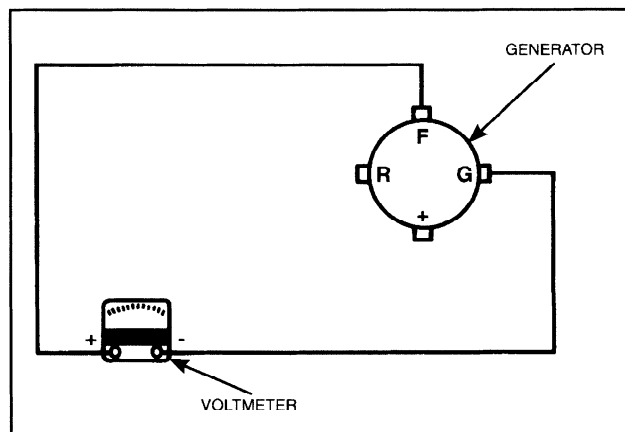

DIAGNOSIS AND TESTING (Continued)

If the foregoing test sequence does not identify the cause of undercharging, it may be due to low regulator output when the system is operating under load.

4. Engine ON.
5. While running the engine at 1600 rpm, measure the "F" terminal voltage. Field voltage should be 10.5 to 11.5 volts initially, and quickly taper off to 7.5 to 8.5 volts as the starting discharge is re-charged. If the voltage is low or fluctuating, the regulator is defective. In that case, replace the regulator.

Overcharging

If the output voltage test indicates an overcharging condition (greater than 14.4 volts), it usually indicates a defective regulator, but not always. If the regulator sense voltage at the "R" terminal is lower than the output voltage

by more than 0.5 volt due to a defective diode trio, a good regulator will increase field current and generator output in an effort to bring the sense voltage up to regulating value. Whether and to what extent the system will overcharge will depend on the nature and degree of the field diode failure, as field current must pass through the field diodes.

Generator Disassembly

If the foregoing series of on-equipment tests has not identified the cause of charging system malfunctions, remove and disassemble the generator for further tests. See "Overhaul" in this section. If specialized test equipment is available for checking diodes and stator windings under operating-load conditions, follow the equipment manufacturer's instructions. If this equipment is not available, refer the job to the nearest Authorized Service Station.

ADJUSTMENTS

Belt Adjustments

1. Check the belt tension with Tool T63L-8620-A. The belt should be within specifications (Specifications Section).
2. If the belt is not within specification, loosen the generator mounting bolt to a snug position and loosen the adjusting arm bolts.
3. **Apply pressure on the generator front housing only** and tighten the adjusting arm to generator bolt.
4. Check the belt tension using Tool T63L-8620-A. Adjust the belt for specified tension.
5. Tighten all mounting bolts.

REMOVAL AND INSTALLATION

Removal

1. Disconnect the battery ground cable.
2. Loosen the generator mounting bolts and remove the adjustment arm-to-generator attaching bolt.
3. Remove the electrical connector from the generator.
4. Disengage the generator belt. Remove the generator mounting bolt, and remove the generator.

Installation

1. Install the generator wiring connector. Position the generator to the engine, and install the spacer (if used) and the generator mounting bolt. Tighten the bolt only finger tight.
2. Install the adjustment arm-to-generator attaching bolt.
3. Position the belt on the pulley and adjust the belt tension using Tool T63L-8620-A. Apply pressure on the generator front housing only, when tightening the belt. Tighten the adjusting arm bolt and the mounting bolt.
4. Connect the battery ground cable.

OVERHAUL

Disassembly

1. Mark both end housings and the stator with a scribe mark for assembly.
2. Remove retaining nut, lockwasher, spacer pulley, spacer, dish washer, fan and fan spacer.
NOTE: Observe position and direction of spacer and dished washer between pulley and fan.
3. Remove regulator and brush holder.
4. Remove four through bolts.
5. Separate the front housing and rotor from the stator and rear housing.
6. Press rotor out of front housing.
7. Remove front bearing retainer and bearing.
8. Support rear bearing with a large washer, incorporating a cut out to accommodate the rotor shaft, and press bearing from shaft.
9. Remove rectifier (diode) assembly retaining screws and lift out stator and rectifier assembly.
10. Unsolder stator to rectifier connections using a pair of pliers as a heat sink to reduce heat spread to diodes.

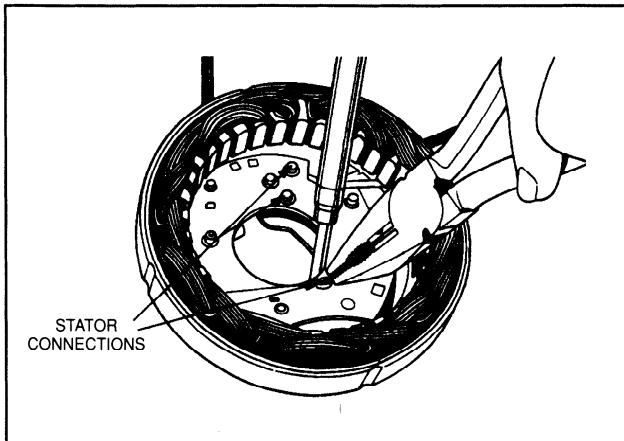

Releasing Front Bearing Retainer

To remove the front bearing, which is pressed on the rotor shaft, it must first be removed from the front housing. It is retained in the housing by a snap ring which is accessible from the front when the pulley and fan are removed.

1. With a pair of snap ring pliers, squeeze the ears of the snap ring together.
2. Rock the snap ring out of its groove.

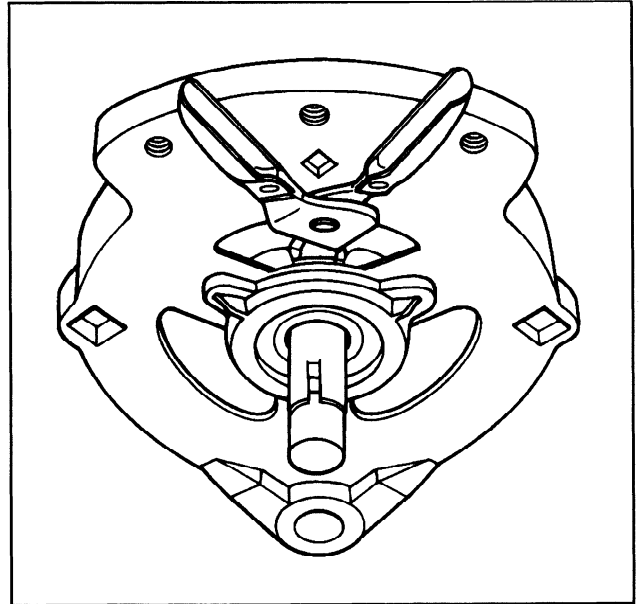

3. Press or tap the rotor shaft and bearing out of the front housing.

Front or Rear Bearing Removal

Remove the bearing from the shaft with a suitable puller and adapter.

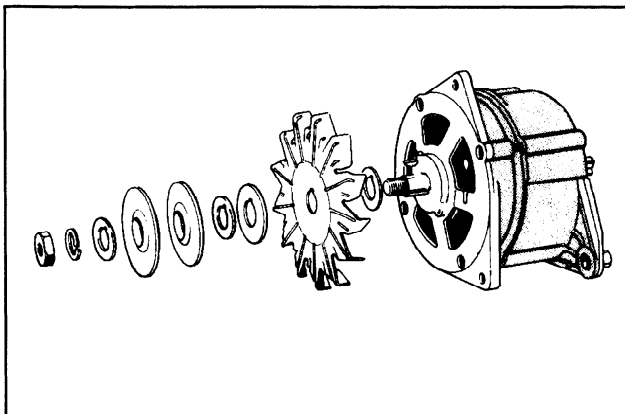
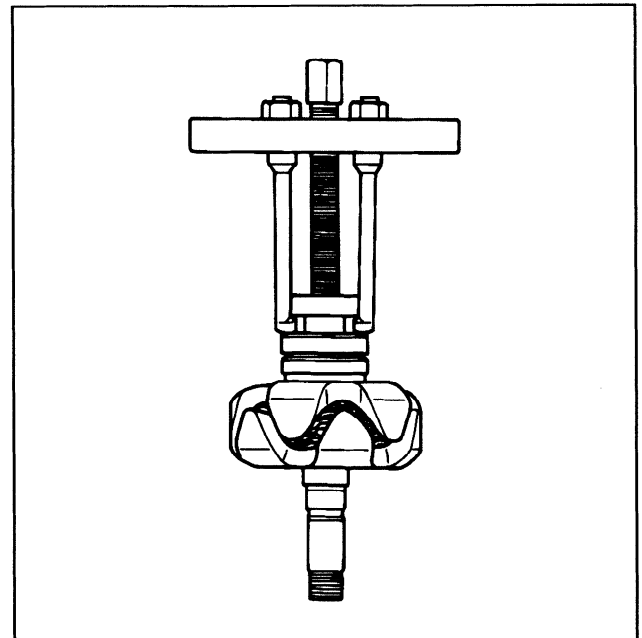

OVERHAUL (Continued)

Front Bearing Installation

Bearing installation is not the reverse of the removal procedure, because the snap ring which retains the front bearing cannot be installed with the bearing in place on the rotor shaft.

1. Seat the bearing in the front housing.
2. Install the snap ring.

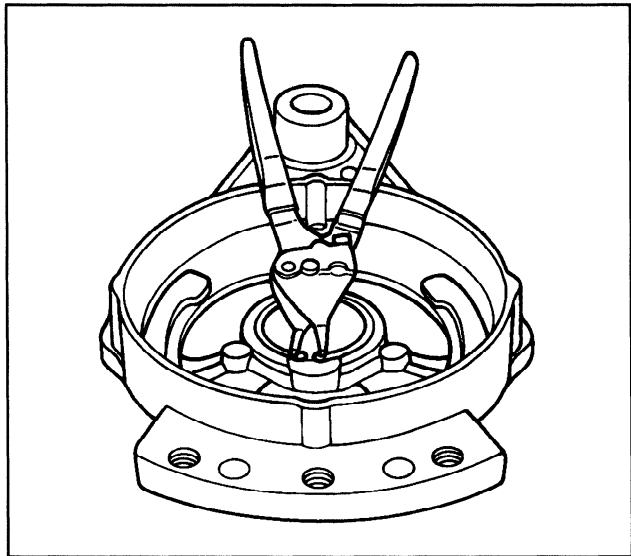

Pressing Front Bearing Onto Shaft

1. Using a suitable sleeve, such as a 17mm (11/16 inch) deep socket, press the bearing (with front housing) onto the rotor shaft. **Apply force to the inner race only.**
2. Press the bearing on until the inner race touches the shoulder on the shaft.

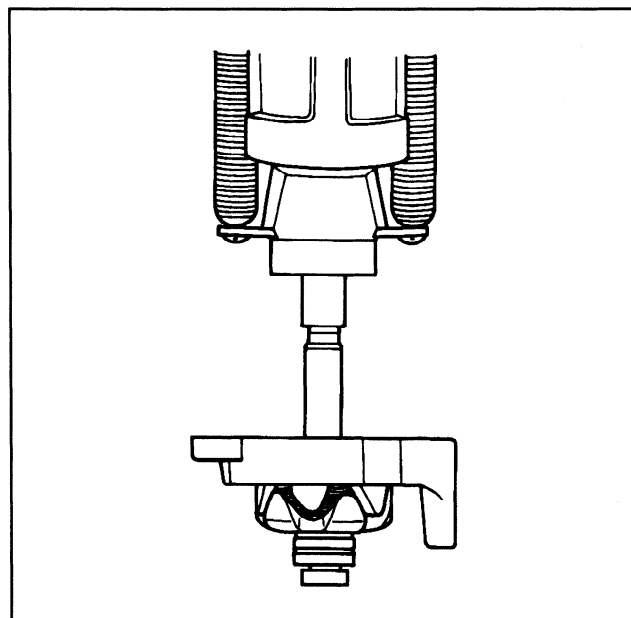

Rear Bearing Recess

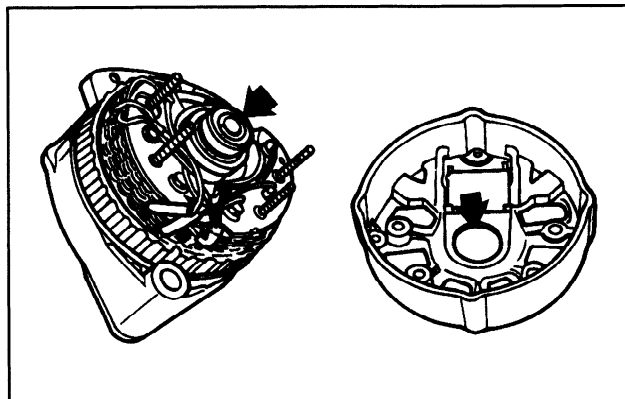

The rear bearing is not locked into its recess in the rear housing. The outer race is prevented from turning by a snug fit in the recess, plus the added friction of a rubber seal ring in a groove in the recess. **Replace the seal ring whenever the generator is disassembled.**

Assembly

1. Resolder stator to rectifier. Use a pair of pliers as a heat sink to reduce heat spread to diodes.

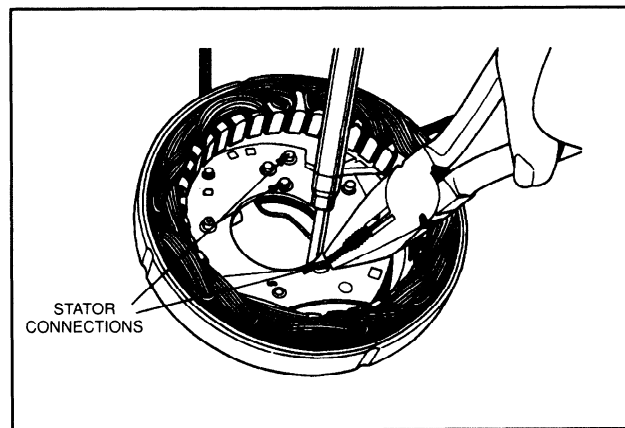

2. Position stator and rectifier assembly in rear housing and install retaining screws.
3. Press rear bearing onto rotor shaft.
4. Install front bearing into front housing. Position retainer plate and install retaining screws.
5. Install rotor to front housing.
6. Position the rear housing and stator assembly over the rotor and align the scribe marks made during disassembly. Seat the machined portion of the stator core into the step in both end housings. Install the housing through bolts.
7. Install the fan spacer, fan, dished washer, spacer, pulley spacer, lockwasher and nut. Tighten nut.

OVERHAUL (Continued)

NOTE: Dished washer must be fitted correctly, with the outer circumference pressing against the fan. In this way, it acts as a vibration damper and prevents fatigue failures.

Output Voltage Test

If possible, check the generator on a bench tester before re-installing. After bench-testing, or if bench-testing is not available, re-install the generator to the engine:

1. Install and connect the generator.
2. Apply proper tension to the drive belt.
3. Make sure the battery cable connections are tight.
4. Key ON.
5. With the engine running at 1000 to 1200 rpm, measure the voltage from the output terminal to ground.

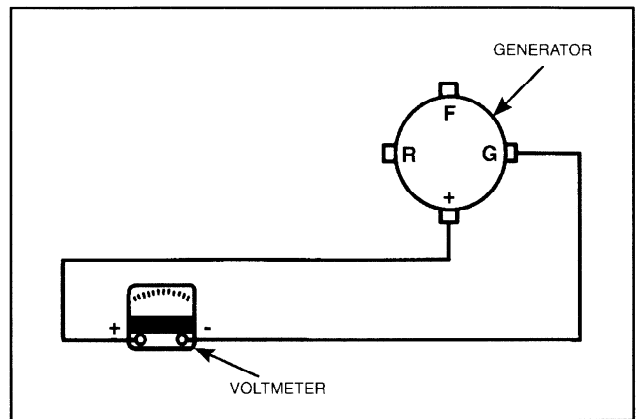

6. Gradually increase the electrical load while observing the voltage reading. If voltage stays between 13.6 and 14.4 volts under all but extreme load conditions, the charging system is working properly.

SECTION TITLE	PAGE	SECTION TITLE	PAGE
BASIC ENGINE	01-1	STARTING SYSTEM	05-1
IGNITION SYSTEM – DISTRIBUTORLESS	02-1	GOVERNOR	06-1
FUEL SYSTEM	03-1	COOLING SYSTEM	07-1
EMISSION CONTROL SYSTEM	03A-1	SPECIFICATIONS	08-1
CHARGING SYSTEM	04-1		

SECTION 05 — Starting System

SUBJECT	PAGE	SUBJECT	PAGE
DESCRIPTION AND OPERATION	05-3	REMOVAL AND INSTALLATION	05-7
TESTING	05-4	OVERHAUL	05-8
Road Service	05-4	Disassembly	05-8
On-Engine Testing	05-4	Cleaning and Inspection	05-8
Starter Cranking Circuit Test	05-4	Assembly	05-10
Starter Load Test	05-5	Permanent-Magnet Starter	05-11
Starter Solenoid Test	05-5	Overhaul	05-11
Bench Tests	05-5	Disassembly	05-11
Starter No-Load Test	05-5	Assembly	05-12
Armature Open Circuit Test	05-6		
Armature and Field Grounded Circuit Test	05-6		

BLANK

DESCRIPTION AND OPERATION

There are two starters available in the VSG range. Most engines are equipped with the Bosch electromagnetic field starter which is detailed in this section. Some engines are equipped with the United Technologies permanent magnet starter. This starter features an inertially-actuated pinion gear which is described later in this section.

The electromagnetic field starter is a four pole, four brush motor with a series field and a solenoid-operated roller clutch drive.

The solenoid assembly is mounted to a flange on the starter drive housing. The entire shift lever mechanism and the solenoid plunger are enclosed in the drive housing, thus protecting them from exposure to dirt and road splash.

The solenoid incorporates two windings, a pull-in-winding and a hold-in winding. Together they provide sufficient magnetic attraction to pull the solenoid plunger into the solenoid.

Engine cranking occurs when the starter solenoid on the starter is energized through the starter control (ignition) switch. When energized, the solenoid shifts the starting motor pinion into mesh with the engine flywheel ring gear. Simultaneously, the main contacts of the solenoid are closed and battery current is directed to the starting motor causing the armature to rotate.

After the engine starts, the starter drive is disengaged when the ignition switch is returned from the start to the ON or RUN position. This opens the circuit to the starter solenoid and the solenoid return spring causes the shift lever to disengage the starter drive from the engine flywheel ring gear.

The starting motor is protected from excessive speed by an overrunning clutch incorporated in the starter drive assembly. The overrunning clutch permits the drive pinion gear to rotate faster than the armature thus disengaging itself from the engine flywheel ring gear when the engine starts.

TESTING

Road Service

On road service calls, connect a booster battery to the system for cases of a starter that will not crank the engine or a starter that cranks the engine very slowly. If the starter does not turn the engine over, even with the booster battery attached, refer to the following tests. **Be certain that correct battery polarity is observed when using a booster battery; positive to positive, and negative to negative connection of the auxiliary cables.**

On Engine Testing

Starter Cranking Circuit Test

These tests will determine whether or not there is excessive resistance in the cranking circuit. Make each test connection as shown. While cranking the engine, observe the voltage drop reading for each test. **Disconnect and ground the high tension lead from the ignition coil to prevent the engine from starting. Connect a remote control switch between the battery terminal of the starter relay and the S terminal of the relay.**

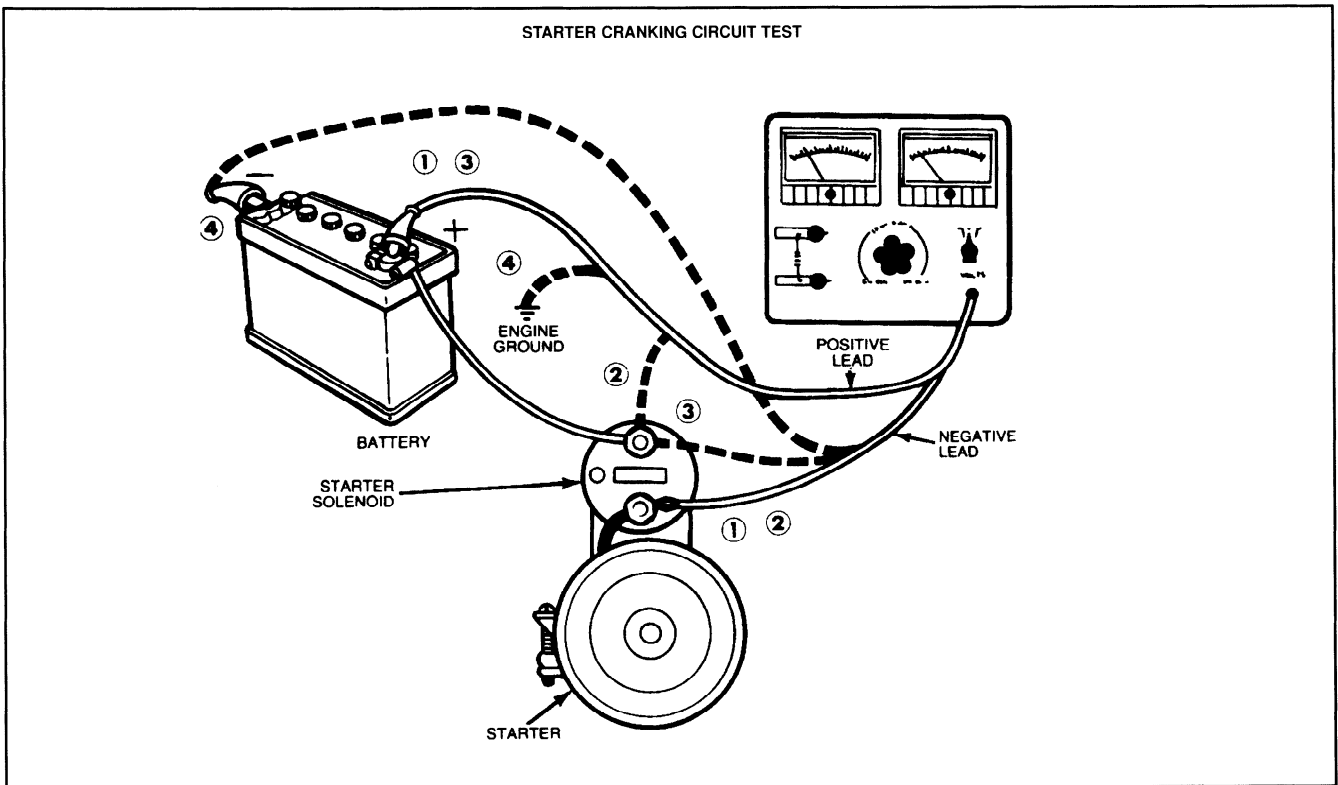

The voltage drop in the circuit will be indicated by the voltmeter (0 to 2 volt range). Maximum allowable voltage drop should be:

1. With the voltmeter negative lead connected to the starter terminal and the positive lead connected to the battery positive terminal (Connection No. 1) 0.5 volt.
2. With the voltmeter negative lead connected to the starter terminal and the positive lead connected to the battery terminal of the starter solenoid (Connection No. 2) 0.3 volt.
3. With the voltmeter negative lead connected to the battery terminal of the starter solenoid and the positive lead connected to the positive terminal of the battery (Connection No. 3) 0.2 volt.
4. With the voltmeter negative lead connected to the negative terminal of the battery and the positive lead connected to the engine ground (Connection No. 4) 0.1 volt.

TESTING (Continued)

Starter Load Test

Connect the test equipment as shown. Be sure that no current is flowing through the ammeter and heavy-duty carbon pile rheostat portion of the circuit (rheostat at maximum counterclockwise position).

Crank the engine with the ignition OFF, and determine the exact reading on the voltmeter. This test is accomplished by disconnecting and grounding the high tension lead from

the ignition coil, and by connecting a jumper from the battery terminal of the starter solenoid to the ignition switch S terminal of the solenoid.

Stop cranking the engine, and adjust the load of the carbon pile until the voltmeter indicates the same reading as that obtained while the starter cranked the engine. The ammeter will indicate the starter current draw under load.

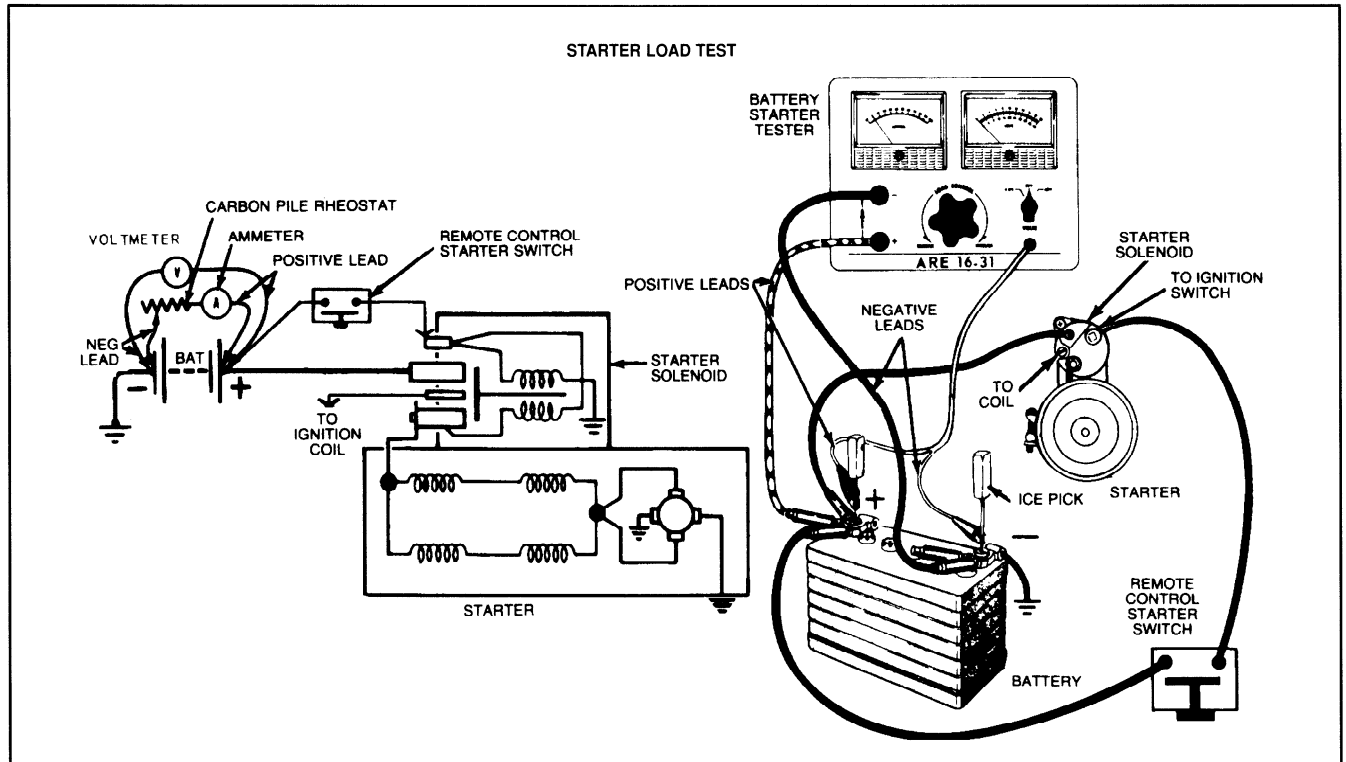

Starter Solenoid Test

If the solenoid does not pull in, in the Starter Load Test, measure the voltage between the starter-mounted solenoid switch terminal and ground with the ignition switch closed. If the voltage is 10 or more volts, a worn or damaged solenoid is indicated. Remove the starter assembly for solenoid replacement.

Bench Tests

Starter No-Load Test

The starter no-load test will uncover such faults as open or shorted windings, rubbing armature, and bent armature shaft. The starter can be tested, at no-load, on the test bench only.

Make the test connections as shown. The starter will run at no-load. Be sure that no current is flowing through the ammeter (rheostat at maximum counterclockwise position). Determine the exact reading on the voltmeter.

Disconnect the starter from the battery, and adjust the load of the rheostat until the voltmeter indicates the same reading as that obtained while the starter was running. The ammeter will indicate the starter no-load current draw.

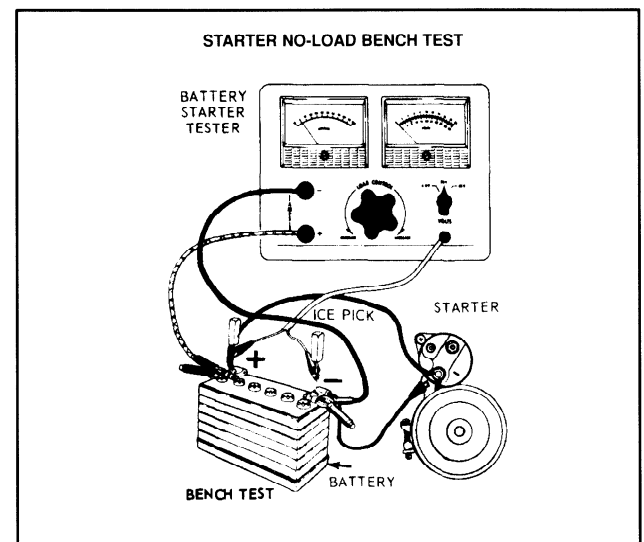

TESTING (Continued)

Armature Open Circuit Test

An open circuit armature may sometimes be detected by examining the commutator for evidence of burning. A spot burned on the commutator is caused by an arc formed every time the commutator segment, connected to the open circuit winding, passes under a brush.

Armature and Field Grounded Circuit Test

The test will determine if the winding insulation has failed, permitting a conductor to touch the frame or armature core.

To determine if the armature windings are grounded, make the connection as shown. If the voltmeter indicates any voltage, the windings are grounded.

Grounded field windings can be detected by first disconnecting the grounded end of the winding where it terminates at the frame, then making the connections as shown. If the voltmeter indicates any voltage, the field windings are grounded.

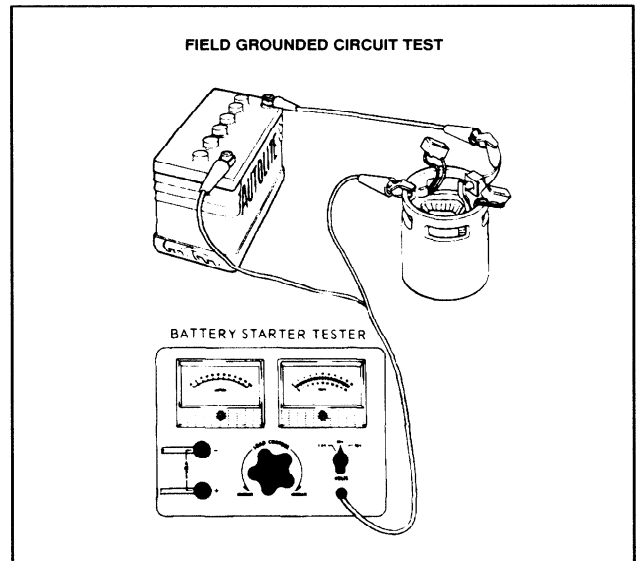
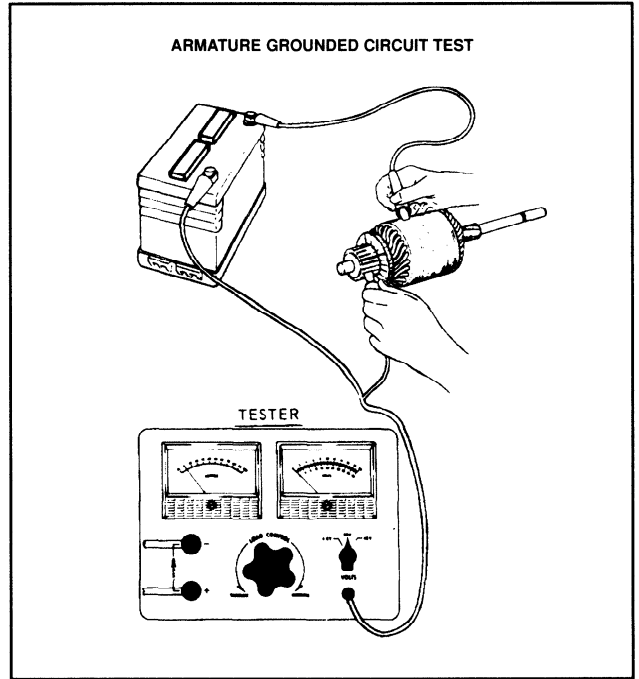

REMOVAL AND INSTALLATION

Removal

1. Disconnect the battery ground cable.
2. Disconnect the cable and wires at the terminals on the solenoid.
3. Remove the starter mounting bolts and remove the starter assembly.

Installation

1. Position the starter assembly to the starter mounting plate and start the mounting bolts.
2. Snug the starting motor mounting bolts while holding the starter squarely against the mounting surface and fully inserted into the pilot hole. Tighten the mounting bolts.
3. Connect the cable and wires to the terminals on the solenoid. Connect the battery ground cable.

OVERHAUL

Disassembly

1. Clamp starter motor in vise fitted with protective soft jaws. Remove nut and washer retaining field winding cable to solenoid and remove cable from stud.
2. Remove solenoid by removing three screws.
3. Remove two screws retaining commutator end housing cap, remove cap and rubber seal.

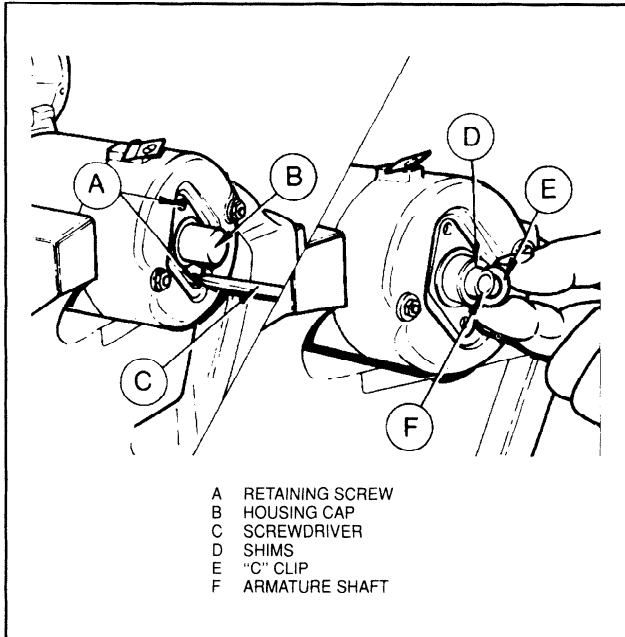

4. Wipe grease from armature shaft, and remove "C" clip and shims from armature end.
5. Remove through bolts or two nuts and washers and lift off commutator end housing.
6. Remove brushes from brush holder assembly by carefully lifting brush retaining/tensioning springs clear and sliding brushes from their holder. Remove brush holder assembly.
7. Separate drive end housing and armature assembly from frame by tapping apart.
8. Remove rubber insert from drive end housing. Remove actuating arm pivot retaining nut and slide pivot pin from housing.
9. Withdraw armature assembly, complete with actuating arm, from drive end housing. Unhook actuating arm from drive pinion flange.

10. To remove drive pinion assembly from armature shaft use a suitably dimensioned tube to separate thrust collar from over "C" clip. Remove "C" clip from its groove and slide thrust collar and drive pinion assembly off armature shaft.

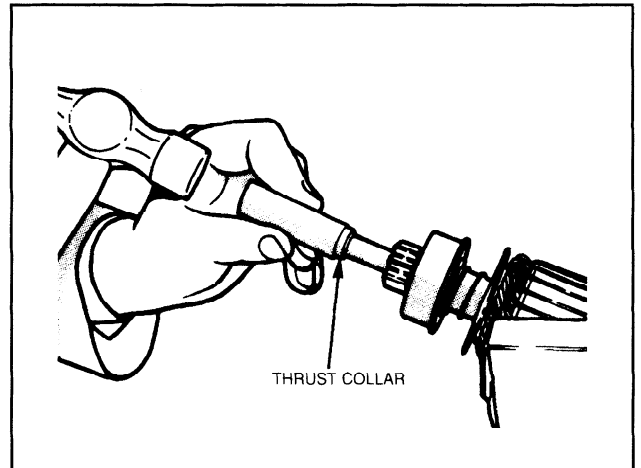

Cleaning and Inspection

1. **Do not wash the drive because the solvent will wash out the lubricant, causing the drive to slip.** Use a brush or compressed air to clean the drive, field coils, armature, commutator, armature shaft front end plate, and rear end housing. Wash all other parts in solvent and dry the parts.
2. Inspect the armature windings for broken or burned insulation and unsoldered connections.
3. Check the armature for open circuits and grounds.
4. Inspect the armature shaft and the two bearings for scoring and excessive wear. If the commutator is rough, turn it.
5. Check the brush holders for broken springs and the insulated holder for shorts to ground. Replace the brushes if worn.
6. Check the brush spring tension.
7. Inspect the field coils for burned or broken insulation and continuity. Check the field brush connections and lead insulation. A brush kit is available. All other assemblies are to be replaced rather than repaired.
8. Examine the wear pattern on the starter drive teeth. The pinion teeth must penetrate to a depth greater than 1/2 the ring gear tooth depth (to eliminate premature ring gear and starter drive failure).
9. Replace starter drives and ring gears that have milled, pitted or broken teeth or that show evidence of inadequate engagement.

OVERHAUL (Continued)

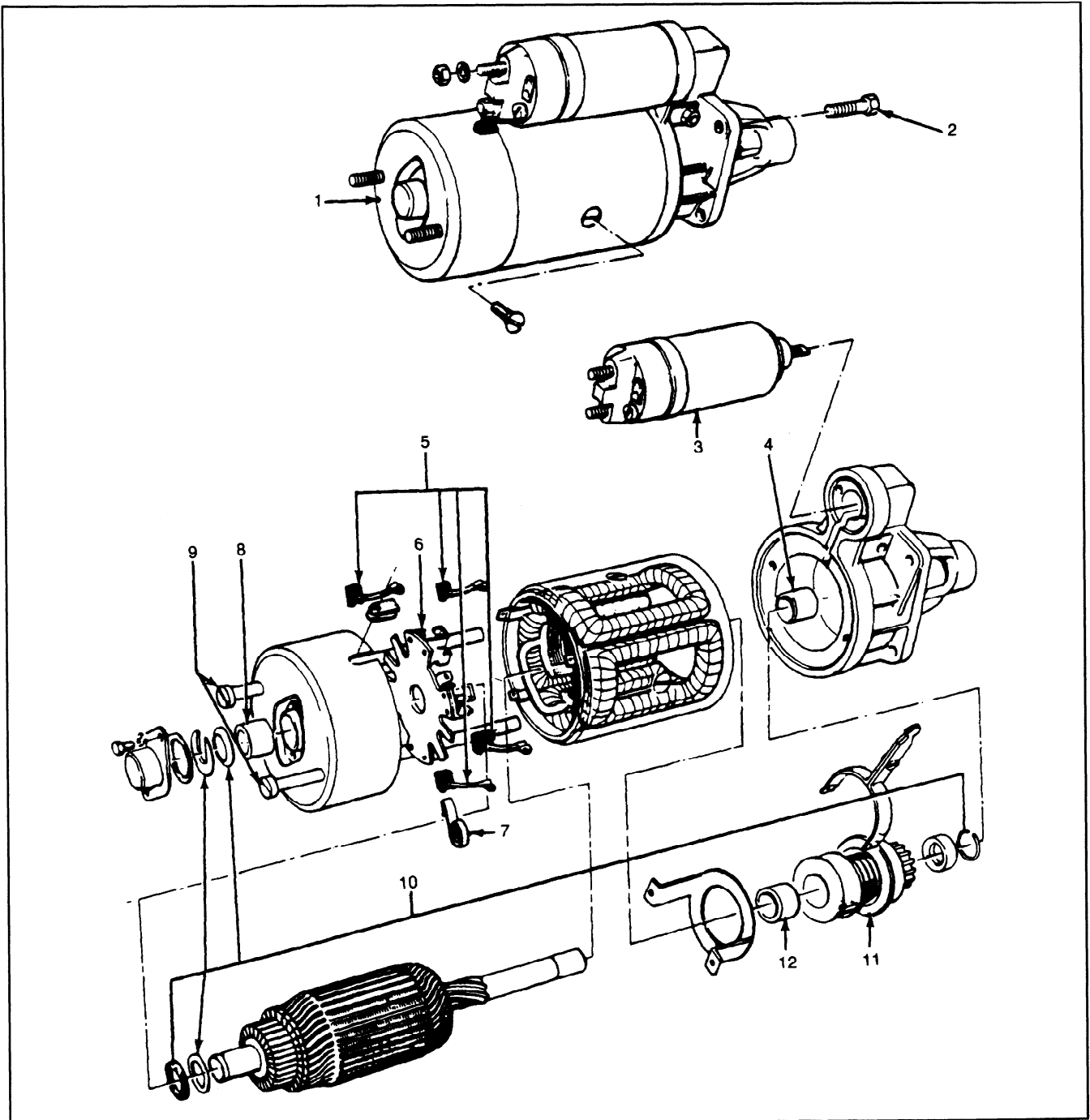

Item	Description
1	Starter motor
2	Bolt
3	Solenoid
4	Bushing
5	Brush set
6	Brushholder

Item	Description
7	Brush spring
8	Brush end bushing
9	Through bolt kit
10	Armature installation kit
11	Drive assembly
12	Bushing

OVERHAUL (Continued)

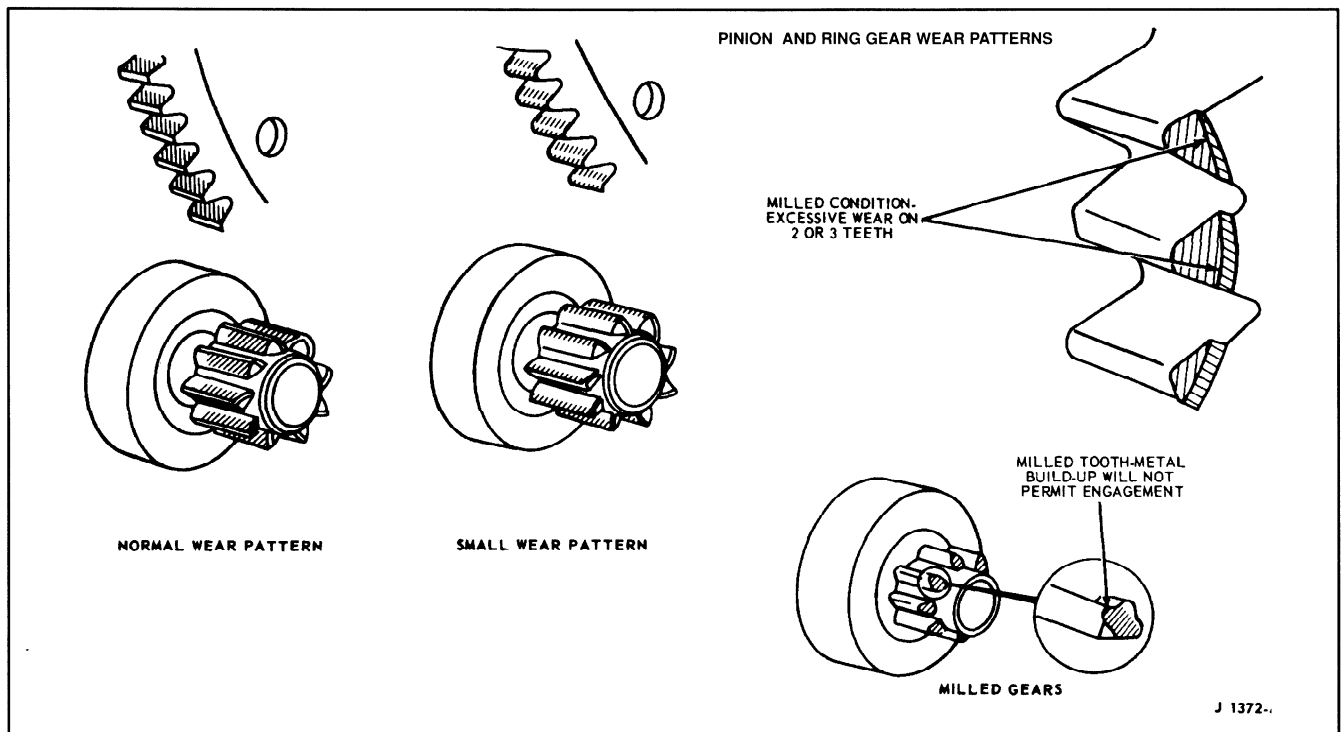

Assembly

1. Slide drive pinion assembly and thrust collar on to armature shaft. Fit "C" clip into its groove in armature shaft and then draw thrust collar over "C" clip.
2. Connect actuating arm on to drive pinion flange. Align armature and actuating arm to drive end housing and couple up components. Install actuating arm pin and secure with retaining nut.
3. Install rubber insert into drive end housing.
4. Guide frame over armature and abut to drive end housing and tap home.
5. Position brush holder over end of armature. Align location "cut-out" in brush holder with "loop" in field windings. Brush will be positively located when through bolts are installed.
6. Position four brushes in their respective brush holder locations and retain with brush springs.
7. Guide commutator end housing into position, sliding rubber insulator into commutator housing "cut-out", and locating two through bolts through housing holes. Secure commutator end housing with two nuts and washers or two through bolts as applicable.
8. Slide armature in its bearings, to obtain maximum possible protrusion of armature shaft at commutator bearing end. Install sufficient shims on armature end play when "C" clip is in place. Fit "C" clip.
9. Place bearing cap seal in position on commutator housing, smear a small quantity of lithium based grease on end of armature shaft and refit bearing cap, securing with two screws.

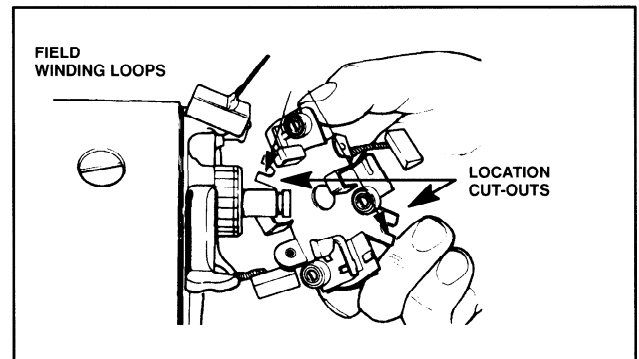

10. Smear lithium based grease onto solenoid armature hook and then locate hook onto actuating arm in drive end housing. Ensure solenoid armature return spring is correctly positioned and then guide solenoid body over armature. Align body with drive end housing and install retaining screws.

OVERHAUL (Continued)

11. Reconnect field winding cable to solenoid and install retaining nut.

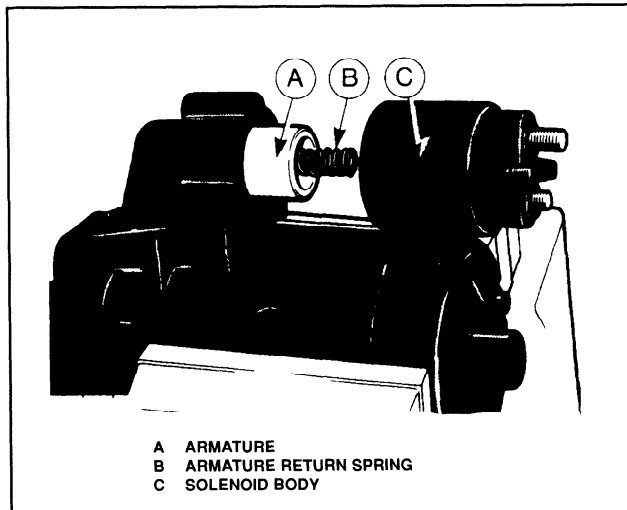
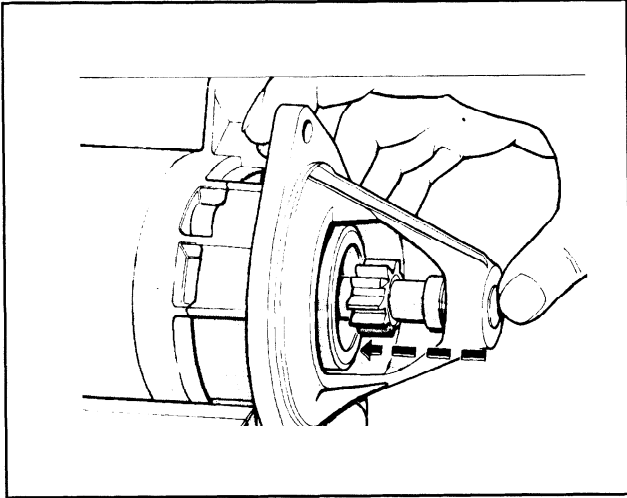

Permanent-Magnet Starter

Some engines in the VSG range are equipped with the United Technologies permanent-magnet starter. This starter has a pinion gear which is actuated by inertial force in place of a starter solenoid. When the starter is energized, inertia causes the pinion gear to move out along a spirally-threaded shaft and engage the flywheel. When the engine has started, the starter motor is de-energized and spring tension causes the pinion gear to move away from the flywheel and back to its original position.

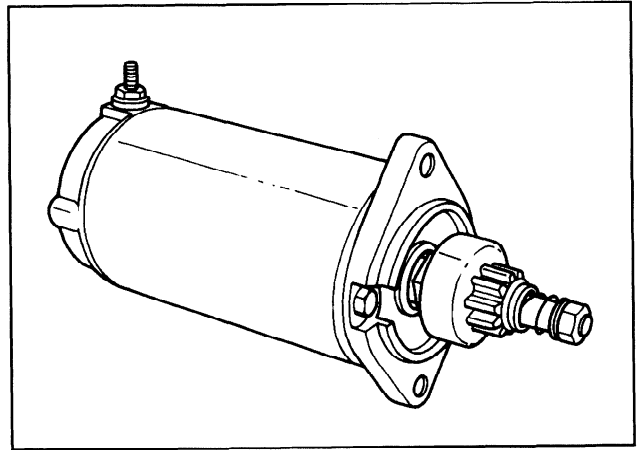

Overhaul Disassembly

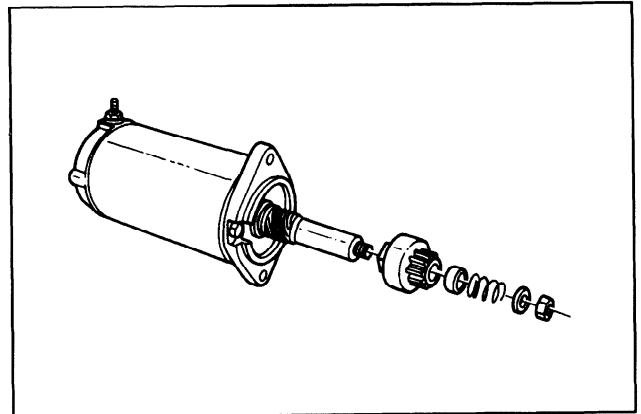

1. Remove the hex nut.
2. Remove the flat washer.
3. Remove the spring.

OVERHAUL (Continued)

4. Remove the spring retainer.
5. Remove the pinion.
6. Remove the through bolts.
7. Remove the drive end plate.

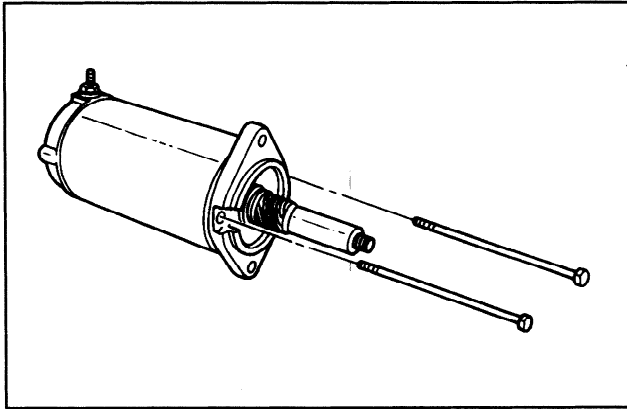

Assembly

1. Install the drive end plate onto the starter body. Make sure the notch in the drive end plate matches the raised crimp on the inside edge of the starter body. This alignment is also shown on the outside of the starter by a raised line on the drive end plate and a corresponding mark on the starter body.

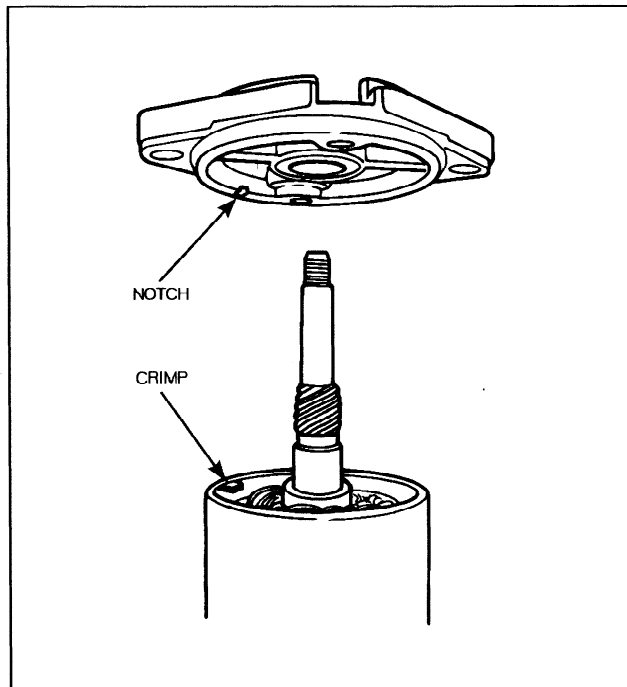

If the armature has been partially or totally removed from the starter body, make sure the brushes are properly seated before re-installing the armature.

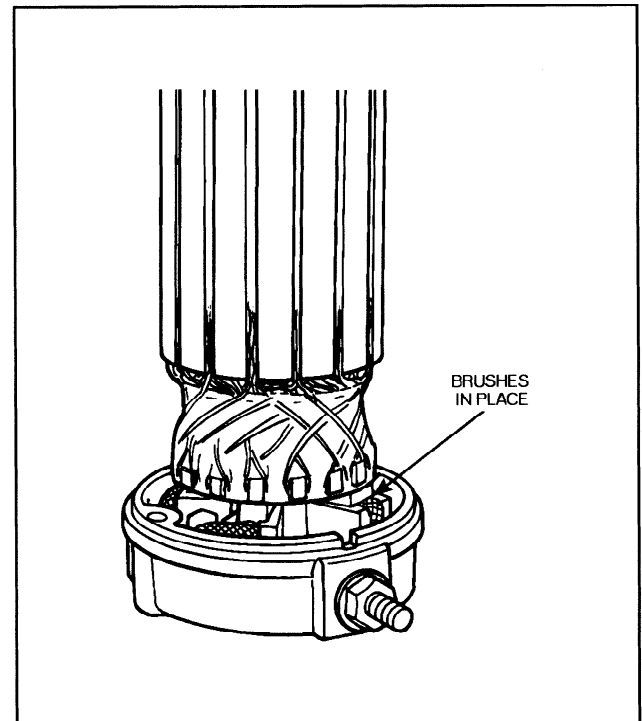
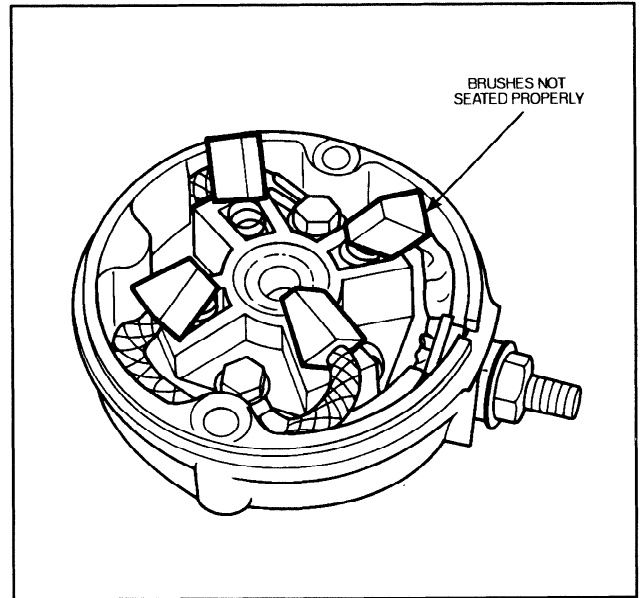

OVERHAUL (Continued)

2. Install the through bolts.

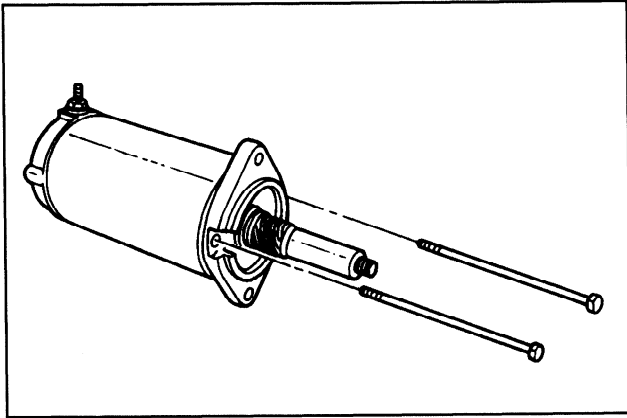

NOTE: The through bolts pass between two powerful magnets and will be attracted to them. A firm side-to-side wiggle near the heads of the bolts may be necessary in order to engage the bolts with their threaded holes.

3. Install the pinion.
4. Install the spring retainer.
5. Install the spring.
6. Install the flat washer.
7. Install the hex nut.

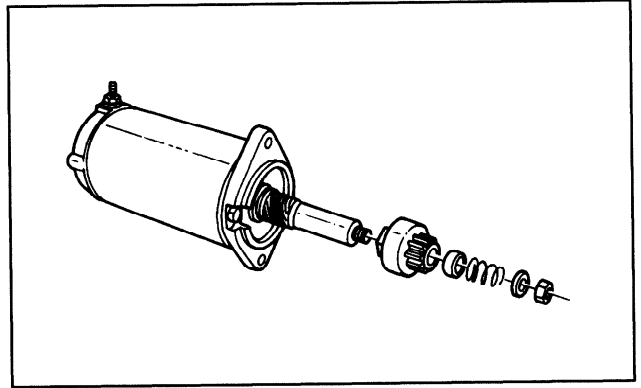

SECTION TITLE	PAGE	SECTION TITLE	PAGE
BASIC ENGINE	01-1	STARTING SYSTEM	05-1
IGNITION SYSTEM – DISTRIBUTORLESS	02-1	GOVERNOR	06-1
FUEL SYSTEM	03-1	COOLING SYSTEM	07-1
EMISSION CONTROL SYSTEM	03A-1	SPECIFICATIONS	08-1
CHARGING SYSTEM	04-1		

SECTION 06 — Governor

SUBJECT	PAGE	SUBJECT	PAGE
DESCRIPTION AND OPERATION	06-3	Increase Spread	06-4
ADJUSTMENTS	06-4	Decrease Spread	06-5
Preliminary Checks	06-4	Low Speed	06-5
Oil Level	06-4	No-Load Surge	06-5
Belt Tension	06-4	REMOVAL AND INSTALLATION	06-6
Throttle Control Rod	06-4	ELECTRONIC DESCRIPTION AND OPERATION	06-7
RPM Adjustments	06-4	ELECTRONIC DIAGNOSIS AND TESTING	06-8
High Speed	06-4	Calibration	06-9
Spread or Sensitivity	06-4		

BLANK

DESCRIPTION AND OPERATION

A mechanical flyweight-type governor and an electronic governor are available for this engine. The mechanical governor is mounted on the right front of the engine and is belt driven from the engine accessory pulley.

A direct mechanical linkage from the governor throttle control lever to the carburetor throttle lever limits carburetor action to the governor setting. As the engine speed

increases, the rotation of the governor shaft increases. Centrifugal force causes the weights to move outward as the rotation of the governor shaft increases. However, a spring retards or limits the movement of the weights until centrifugal force overcomes the spring tension. At this time the weights are forced outward closing the throttle plates through the linkage to the throttle shaft.

ADJUSTMENTS

Preliminary Checks

Three preliminary checks must be made on the mechanical governor before attempting any repair adjustments. These are the governor oil level, drive belt tension and the throttle control rod length.

Oil Level

Clean the body of the governor in the area of the fill plug. Remove the oil level plug. If oil drips out, the level is full. If oil doesn't drip out, remove the oil fill plug and add 10W-30 or 10W-40 engine oil into the fill hole until it starts dripping out of the oil level hole. Install the oil level and oil fill plugs.

Belt Tension

Belt tension should be checked on a cold belt only.

1. Install belt tension tool (T63L-8620-A) on the drive belt and check the tension.

BELT TENSION

New	95 N•m (70 lb-ft)
Used	68 N•m (50 lb-ft)
(A used belt is one that has been in operation for 10 minutes or more.)	

2. If adjustment is required, loosen the governor adjusting bolts and move the governor until the correct tension is obtained.
3. Remove the gauge. Tighten the governor adjusting bolts. Install the tension gauge and recheck the belt tension.

Throttle Control Rod

1. Manually move the governor throttle lever to the maximum open throttle with spring tension on the governor.
2. Check the gap between the carburetor throttle shaft lever and its maximum open position stop. It should be 0.8-1.6mm (1/32 to 1/16 inch) wide.
3. If adjustment is necessary, loosen the control rod ball joint locknuts, remove the rod from the carburetor throttle lever and adjust the length of the rod with the ball joints.
4. Install the throttle control rod on the carburetor throttle lever and recheck the gap. Tighten the locknuts.

CAUTION: Be sure the throttle control rod is properly installed with the long end at the governor to prevent binding on the ignition wires.

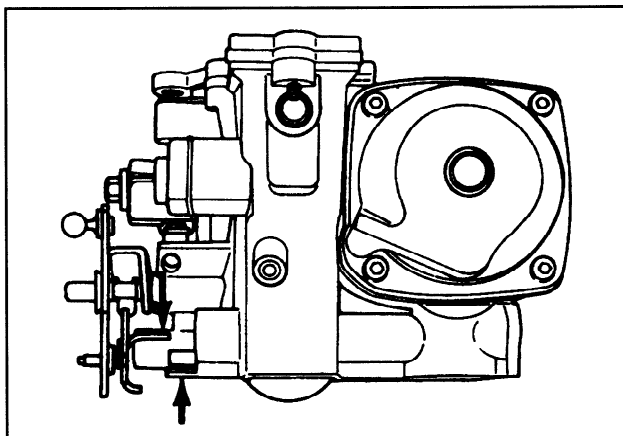

RPM Adjustments

High Speed

First attach a tachometer to the engine, then run the engine until it reaches normal operating temperature.

1. Loosen the locknut on the high-speed stop screw.
2. Disengage engine load.
3. Slowly pull the throttle to desired maximum engine speed.
4. Adjust the high-speed stop screw on the governor to attain the desired maximum engine speed. Do not exceed the recommended maximum rpm.
5. Tighten the locknut.

Spread or Sensitivity

Proper governor operation requires a difference between full-load and no-load governed speed. Too small an rpm spread between the two speeds will cause governor hunting and surging. Too large a spread will cause low response. For this governor, normal rpm spread is approximately 250 rpm with the full-load speed range of 2000-2800 rpm.

Increase Spread

1. With the engine running under no-load at maximum governed speed, loosen the locknuts and adjust the screw to move the spring away from the lever hub. Tighten the locknuts.
2. Recheck governor operation under full-load and no-load conditions to determine if operation is stabilized and sensitivity is satisfactory.
3. Readjust the governor high-speed stop screw to maintain the correct high speed under load.

ADJUSTMENTS (Continued)

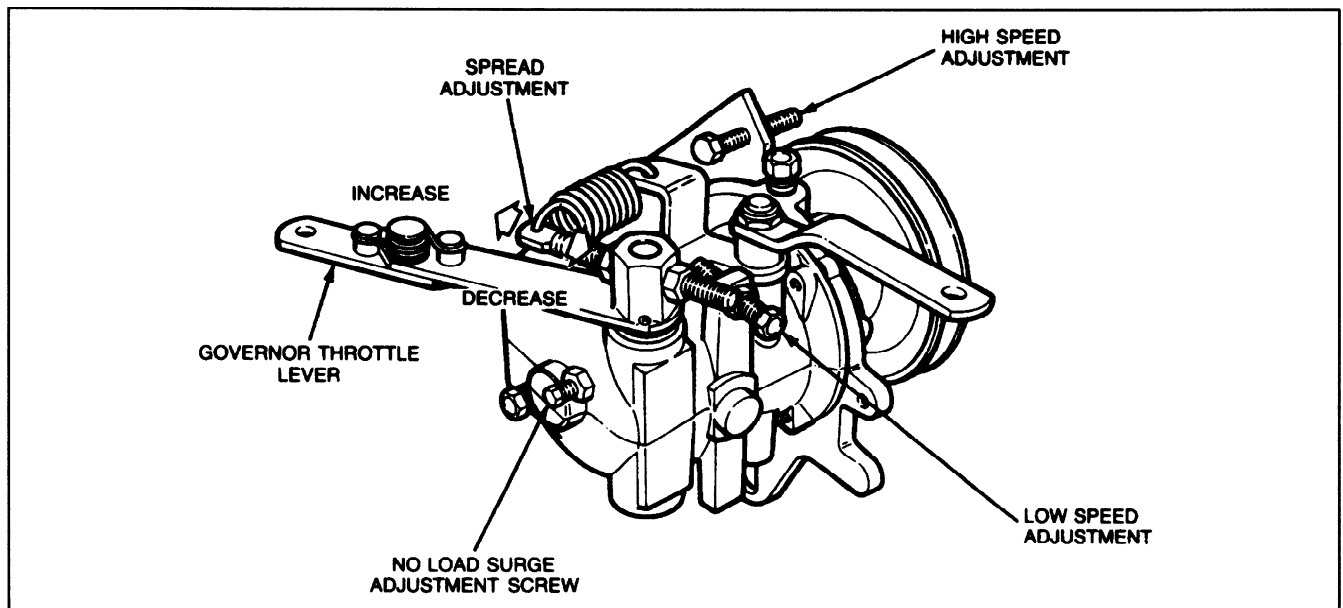

Decrease Spread

1. With the engine under no-load at maximum governed speed, loosen the locknuts and adjust the screw to move the spring towards the lever hub. Tighten the locknuts.
2. Recheck governor operation under load and no-load conditions.
3. Readjust the governor high-speed stop screw to maintain the correct high speed under load.

Low Speed

1. Attach a tachometer and move the hand throttle or variable speed lever to the closed position.
2. Adjust the carburetor idle speed screw to obtain the desired idle speed.

No-Load Surge

The no-load surge adjustment is set at the factory and rarely requires adjustment. If necessary, this adjustment can be used to prevent hunting and surging and **no-load speeds**, provided the rpm spread adjustment is set properly.

1. Make the adjustment with the tachometer installed. Increase the engine speed with the hand throttle or variable speed lever to 75 rpm lower than the maximum no-load desired control rpm.
2. Loosen the no-load surge adjustment screw locknut and turn the screw inward until the rpm increases to the desired control rpm.

CAUTION: Do not turn the screw in all the way. It will interfere with proper governor operation and prevent the governor from returning the engine to idle speed.

3. Readjust the governor high-speed stop screw to maintain the correct high-speed under load.

REMOVAL AND INSTALLATION

Removal

1. Disconnect hand throttle connection at governor variable speed lever.
2. Disconnect governor to carburetor throttle control rod at governor.
3. Loosen governor mounting nuts and bolts and move governor towards engine to loosen drive belt.
4. Remove drive belt from governor pulley.
5. Remove governor to bracket attaching bolts and remove governor.

Installation

1. Position the governor to the mounting bracket and install the attaching bolts snugly.
2. Position drive belt to governor pulley and move the governor away from the engine to tighten the belt. Tighten the attaching bolts.
3. Adjust the belt tension.
4. Connect the governor to carburetor throttle control rod. Adjust the rod as described previously.
5. Connect hand throttle cable to governor variable speed lever. Adjust cable as necessary to permit operation from idle to maximum speed.

ELECTRONIC DESCRIPTION AND OPERATION

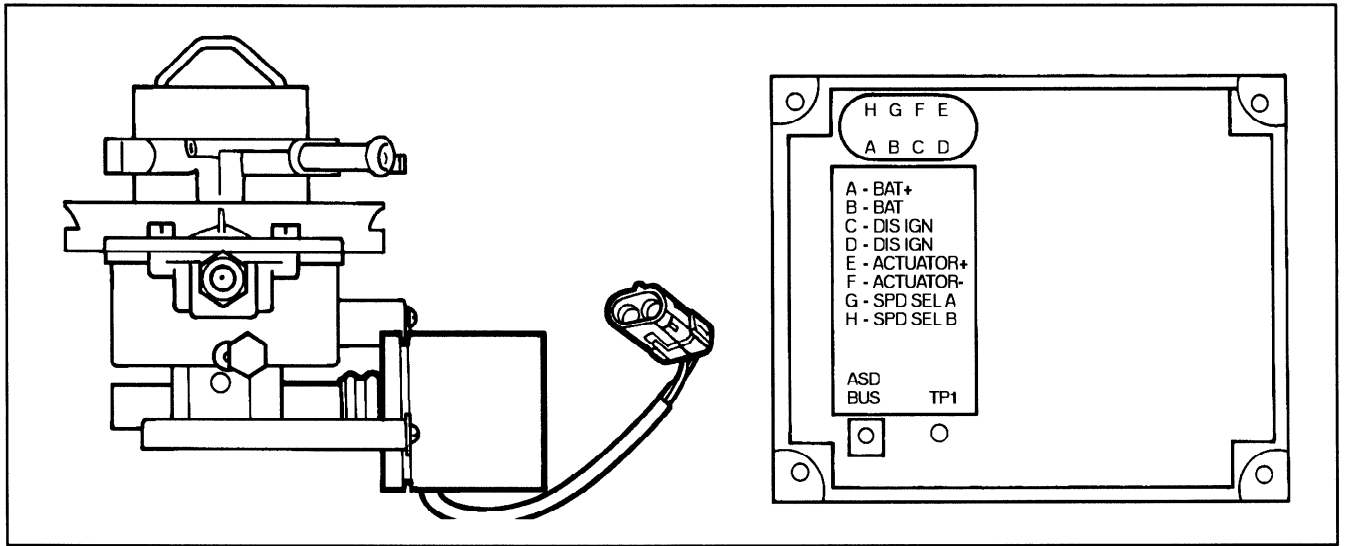

The Barber Colman electronic governor consists of three main components:

- a controller
- an actuator
- a carburetor

The controller is a Barber Colman model 10851 digital unit. This controller allows up to four engine speeds to be used on one application. The operator changes the engine speeds via a run speed select switch, mounted on the control panel of the machine.

These governors are isochronous in operation; there is no governor droop. The governor maintains the same engine speed from no-load to full-load operation. Each controller

can be programmed with up to four separate engine speeds. The carburetor and actuator are integrated into one unit.

The carburetor is a Zenith model 33, offered with either a manual or automatic choke. It is spring loaded to keep carburetor at its minimum fuel position when no power is applied. The feature causes the carburetor to go fully closed in the event of governor power failure.

The rotary actuator is mounted directly to the end of the throttle shaft. This feature eliminates any need for throttle linkage. The actuator is electrically connected to the controller through a two-wire Packard connector. If the governor is used with any other fuel system, such as LPG, then a linear actuator is available.

ELECTRONIC DIAGNOSIS AND TESTING

This governor system is comprised of three major components: the carburetor, actuator and controller. The objective of this document is to help a technician identify which component is creating a problem so it can be fixed or replaced.

CONDITION	POSSIBLE SOURCE	ACTION
I. Governor appears dead.	1. Battery power is not supplied to controller.	Remove the connector from the controller and with a voltmeter check for battery power across pins A & B of the wiring harness connector.
		If battery power is not present, check wiring to the controller.
	2. Controller is not receiving the speed signal NOTE: This controller receives its speed signal from the ignition.	If the controller is connected to an engine with a distributor, pins C & D should both be connected to the negative side of the coil, or the tachometer output.
		If the controller is connected to an engine with a DIS ignition, pin C should be connected to one of the two tachometer outputs, and pin D should be connected to the other tachometer output. The DIS ignition utilizes two coils. NOTE: Do not short the tach leads; doing so could damage the spark controller.
		Using an ohmmeter, check continuity from pins C & D to the termination points. If continuity is not present, repair the wiring.
	3. Actuator fails to operate.	Remove the 2-pin connector at the actuator. With a DC voltmeter, check between the purple wire and chassis (battery) ground. The voltmeter should read 12 volts, \pm 2 volts.
If the voltage is low, disconnect the 8-pin connector from the controller, and check continuity between the wiring harness pins E & F, to their respective actuator terminals. If there is no continuity, check for openings in the wires.		
Using a voltmeter, check for battery voltage from controller terminal E to chassis (battery) ground. If battery power is not found, replace the controller and check the actuator and actuator wiring for grounds and shorts. NOTE: Check wiring before replacing controller. Bad wiring might destroy the new controller.		
Check continuity across actuator wires. 2 ohms \pm .5 ohm should be measured. Check the continuity of actuator wires to the case. The ohms measured should be 1M or greater. If these values are out of tolerance, replace actuator.		
II. Engine doesn't change speeds.	1. Incorrect engine speed.	With the engine running, connect battery power to pin H. This will select Run 2. If Run 2 is set a higher speed than Run 1 and the speed does not change, replace the controller. Contact OEM for speed settings.
		With the engine running, connect battery power to pin G. This will select Run 3. If Run 3 is set higher than the previous speed and the speed does not change, replace the controller. Contact OEM for speed settings.
		With the engine running, connect battery power to pins G & H. This will select Run 4. If Run 4 is set higher than the previous speed and the speed does not change, replace the controller. Contact OEM for speed settings.

ELECTRONIC DIAGNOSIS AND TESTING (Continued)

CONDITION	POSSIBLE SOURCE	ACTION
III. Engine is hunting.	1. Engine is misfiring due to idle mixture mis-adjustment. This causes engine hunt at no-load condition.	Disconnect the connector from the controller. The governor is now disabled and a warm engine should be running at a mechanical idle of approximately 600 RPM.
		If the engine is not running at the mechanical idle and is governed by an integrated carburetor, loosen the three actuator fasteners and rotate the actuator to achieve an idle of 600 RPM. If the engine is governed by a linear actuator, adjust the idle speed screw to achieve 600 RPM.
		Slowly rotate the idle mixture screw clockwise (CW) until the engine speed begins to decrease. Slowly turn the idle mixture screw counterclockwise (CCW) until the engine speed begins to decrease. Now, turn the idle mixture screw clockwise (CW) until maximum idle speed is achieved. The idle mixture is now adjusted.
	2. Engine is misfiring.	Disconnect the connector from the controller and consult the engine repair manual.

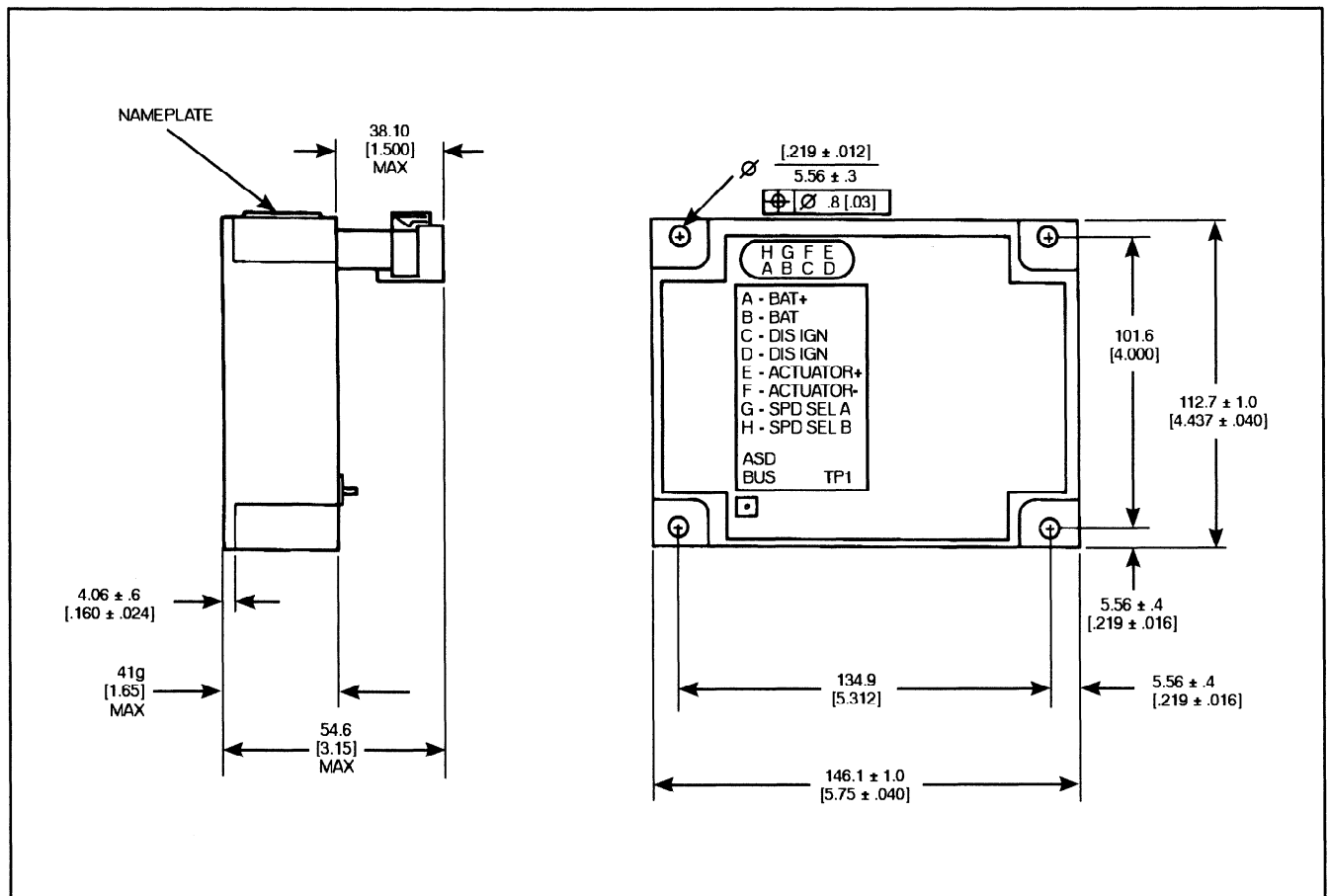

Calibration

Initial speed settings, as well as other parameters, can be set using a special interface connector, and an IBM compatible PC 286 minimum with 640K RAM, of which

512K of conventional RAM must be available. Also required is a 1.44 Meg High Density floppy drive and a VGA graphic display. Programming of the controller is covered in a separate publication.

ELECTRONIC DIAGNOSIS AND TESTING (Continued)

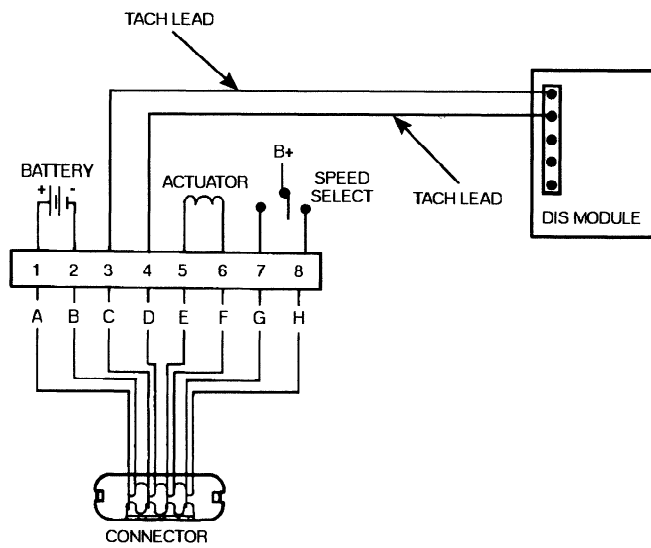
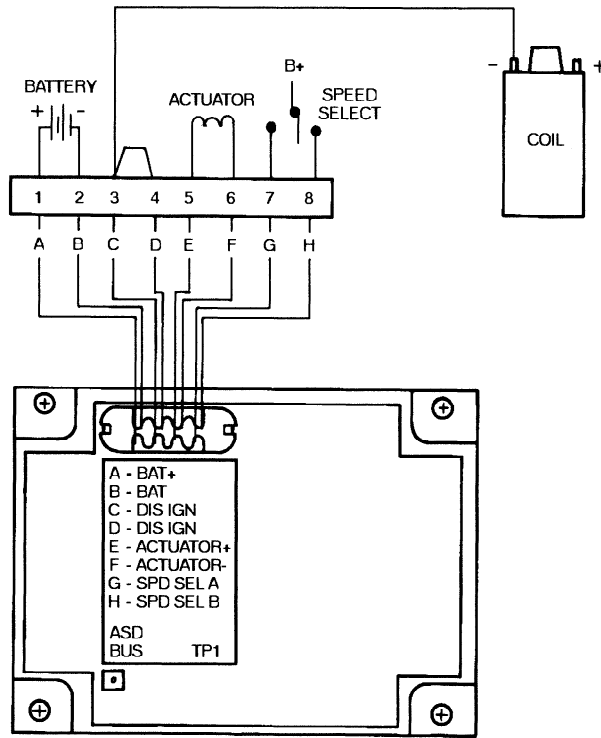

SECTION TITLE	PAGE	SECTION TITLE	PAGE
BASIC ENGINE	01-1	STARTING SYSTEM	05-1
IGNITION SYSTEM – DISTRIBUTORLESS	02-1	GOVERNOR	06-1
FUEL SYSTEM	03-1	COOLING SYSTEM	07-1
EMISSION CONTROL SYSTEM	03A-1	SPECIFICATIONS	08-1
CHARGING SYSTEM	04-1		

SECTION 07 — Cooling System

SUBJECT	PAGE	SUBJECT	PAGE
DESCRIPTION AND OPERATION	07-3	ADJUSTMENTS	07-4
		Drive Belt	07-4
		Belt Tension	07-4

BLANK

DESCRIPTION AND OPERATION

The system is of the full flow type with a centrifugal pump. The thermostat, located in the cylinder head, controls the flow through the system maintaining the proper temperature.

The coolant flow is from the bottom of the radiator to the pump which delivers it to the cylinder block. It then flows through the cored passages to cool the entire length of each cylinder wall. Upon reaching the rear of the cylinder block, the coolant is directed upward into the cylinder head

where it cools the combustion chambers, valves and valve seats.

The coolant from the cylinder head flows past the thermostat, if it is open, through the coolant outlet housing and into the top of the radiator.

Another passage in the head routes the warm coolant through the intake manifold to help atomize the fuel mixture, and then through a hose to the inlet hose of the water pump.

ADJUSTMENTS

Drive Belt

The fan drive belt should be properly adjusted at all times. A loose drive belt can cause improper generator, fan and water pump operation. A belt that is too tight places a severe strain on the water pump and the generator bearings.

A properly tensioned drive belt minimizes noise and also prolongs the service life of the belt. Therefore, it is recommended that a belt tension gauge be used to check and adjust the belt tension. **Any belt that has been operated for a minimum of 10 minutes is considered a used belt, and when adjusted, it must be adjusted to the used tension shown in the specifications.**

Belt Tension

1. Install the belt tension tool on the drive belt and check the tension.
2. If adjustment is necessary, loosen the generator mounting and adjusting arm bolts. Move the generator toward or away from the engine until the correct tension is obtained. Remove the gauge.
3. Tighten the generator adjusting arm and mounting bolts. Install the tension gauge and recheck the belt tension.

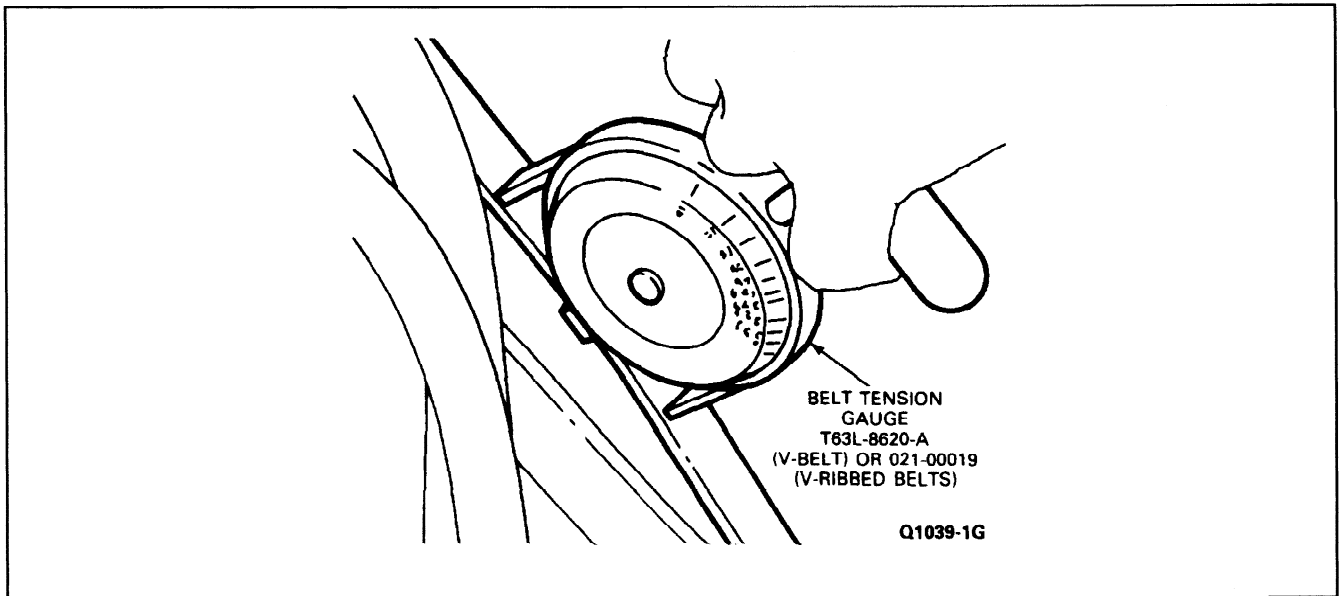

SECTION TITLE	PAGE	SECTION TITLE	PAGE
BASIC ENGINE	01-1	STARTING SYSTEM	05-1
IGNITION SYSTEM – DISTRIBUTORLESS	02-1	GOVERNOR	06-1
FUEL SYSTEM	03-1	COOLING SYSTEM	07-1
EMISSION CONTROL SYSTEM	03A-1	SPECIFICATIONS	08-1
CHARGING SYSTEM	04-1		

SECTION 08 — Specifications

SUBJECT	PAGE	SUBJECT	PAGE
SPECIFICATIONS	08-3	Special Service Tools	08-8
Engine Model Years 1993+	08-3	Conversion Factors	08-8
		Torque Specifications	08-8

BLANK

SPECIFICATIONS

ENGINE MODEL YEARS 1993+

General Specifications	
VSG-411	4 Cylinder — 1.1 Liter
VSG-413	4 Cylinder — 1.3 Liter
Bore and Stroke 1.1L	68.68 and 75.48 mm (2.704 and 2.971 in)
1.3L	73.96 and 75.48 mm (2.912 and 2.971 in)
Firing Order	1-2-4-3
Idle Speed	700-800 rpm
Rated Engine Speed — Maximum	Full Load 2800 rpm
	No Load 3050 rpm
Cylinder Block	
Number of Main Bearings	5
Cast Marks 1.1L	93BM-6015-AA
1.3L	89BM-6015-FA
Cylinder Bore Diameter 1.1L	68.680-68.710 mm (2.7039-2.7051 in)
1.3L	73.94-73.97 mm (2.9110-2.9122 in)
Out-of-Round Maximum	0.038 mm (0.0015 in)
Wear Limit	0.127 mm (0.005 in)
Taper Maximum	0.0254 mm (0.0010 in)
Wear Limit	0.254 mm (0.010 in)
Main Bearing Bore Standard	60.623-60.636 mm (2.3868-2.3872 in)
Oversize	61.003-61.016 mm (2.4017-2.4022 in)
Camshaft Bearing Bore Standard	42.888-42.918 mm (1.6886-1.6896 in)
Oversize	43.396-43.420 mm (1.7086-1.7094 in)
Cylinder Block Liner Bore Diameter 1.1L	71.826-71.852 mm (2.8278-2.8288 in)
1.3L	77.086-77.112 mm (3.0349-3.0359 in)
Deck Height (Oil Pan Rail to Head Deck) 1.1L	194.6 ± 0.065 mm (7.6614 ± 0.0026 in)
1.3L	194.6 ± 0.065 mm (7.6614 ± 0.0026 in)
℄ of Crankshaft Above Oil Pan Rail 1.1L & 1.3L	2.578 ± 0.115 mm (0.1015 ± 0.0045 in)

All specifications are in millimeters (inches).

For Conversion Factors see page 5.

SPECIFICATIONS (Continued)

ENGINE MODEL YEARS 1993+

Crankshaft	
Main Bearing Journal Dia. 1.1L Standard	56.99-57.00 mm (2.2437-2.2441 in)
Yellow	56.98-56.99 mm (2.2433-2.2437 in)
Main Bearing Journal Dia. 1.3L Standard	56.980-57.000 mm (2.2433-2.2441 in)
Yellow	—
Main Bearing Clearance 1.1L	0.009-0.046 mm (0.0004-0.0018 in)
Main Bearing Clearance 1.3L	0.009-0.056 mm (0.0004-0.0022 in)
Rod Bearing Journal Dia. 1.1L Standard	40.99-41.01 mm (1.6138-1.6145 in)
Green	40.74-40.76 mm (1.6039-1.6047 in)
Rod Bearing Journal Dia. 1.3L Standard	42.99-43.01 mm (1.6926-1.6933 in)
Green	42.74-42.76 mm (1.6827-1.6834 in)
Rod Bearing Clearance 1.1L and 1.3L	0.006-0.060 mm (0.0003-0.0023 in)
End Play 1.1L and 1.3L	0.075-0.285 mm (0.003-0.011 in)
Camshaft	
Journal Diameter 1.1L and 1.3L	39.615-39.636 mm (1.5596-1.5605 in)
Bearing I.D. 1.1L and 1.3L	39.662-39.713 mm (1.5615-1.5635 in)
Bearing Clearance (Standard Bearing) 1.1 and 1.3L	0.026-0.067 mm (0.001-0.002 in)
Wear Limit	0.0762 mm (0.003 in)
Camshaft Thrust Plate Thickness 1.1L and 1.3L	4.457-4.508 mm (0.1754-0.1774 in)
End Play	0.02-0.19 mm (0.0008-0.0075 in)
Cam Lift 1.1L Intake	5.15 mm (0.203 in)
Exhaust	4.92 mm (0.194 in)
Camshaft Lift 1.3L Intake	5.70 mm (0.224 in)
Exhaust	5.76 mm (0.227 in)
Drive 1.1L and 1.3L	Chain
Connecting Rod	
Piston Pin Bore 1.1L and 1.3L	17.990-18.010 mm (0.7083-0.7091 in)
Rod Bearing Bore 1.1L and 1.3L	43.990-44.010 mm (1.7319-1.7327 in)
Maximum Twist or Bend	0.10 mm (0.004 in)
End Play 1.1 and 1.3L	0.10-0.25 mm (0.004-0.010 in)
Piston	
Diameter 1.1L	68.670-68.700 mm (2.7035-2.7047 in)
Diameter 1.3L	73.930-73.955 mm (2.9107-2.9116 in)
Piston to Bore Clearance	0.015-0.050 mm (0.0006-0.0019 in)

All specifications are in millimeters (inches).
For Conversion Factors see page 8.

SPECIFICATIONS (Continued)

ENGINE MODEL YEARS 1993+

Piston Pin	
Diameter 1.1L and 1.3L	18.026-18.029 mm (0.7097-0.7098 in)
Length 1.1L	58.6-59.4 mm (2.31-2.33 in)
1.3L	63.6-64.4 mm (2.51-2.53 in)
Interference Fit in Rod at 21°C 1.1L and 1.3L	0.016-0.048 mm (0.0006-0.0018 in)
Clearance in Piston at 21°C 1.1L and 1.3L	0.008-0.014 mm (0.0003-0.0006 in)
Piston Rings	
Top Compression Ring Thickness 1.1L and 1.3L	1.503-1.505 mm (0.05918-0.05925 in)
Bottom Compression Ring Thickness 1.1L and 1.3L	1.728-1.740 mm (0.0680-0.0685 in)
Top Compression Ring Side Clearance 1.1L and 1.3L	.013-.027 mm (0.0005-0.0011 in)
Bottom Compression Ring Side Clearance 1.1L and 1.3L	.005-.042 mm (0.0002-0.0017 in)
Compression Ring Side Clearance — Wear Limit	0.15 mm (0.006 in)
Oil Ring Thickness 1.1L and 1.3L	2.978-2.990 mm (0.1172-0.1177 in)
Oil Ring Side Clearance 1.1L and 1.3L	0-.032 mm (0-0.0012 in)
Top Compression Ring — Standard Bore — Ring Gap ^{b/}	0.25-0.45 mm (0.010-0.017 in)
Bottom Compression Ring — Standard Bore — Ring Gap ^{b/}	0.25-0.45 mm (0.010-0.017 in)
Oil Ring — Standard Bore — Ring Gap ^{b/}	0.20-0.40 mm (0.008-0.015 in)
Cylinder Head	
Maximum permissible cylinder head distortion 1.1L and 1.3L: Measured over a distance of 26 mm	0.04 mm (0.0015 in)
Measured over a distance of 152 mm	0.08 mm (0.003 in)
Measured over the entire length	0.15 mm (0.006 in)
Valve Stem Bore 1.1L and 1.3L	7.063-7.094 (0.2781-0.2793 in)
Valve Seat Angle	45°
Valve Seat Insert — Exhaust, Outside Diameter ^{c/} 1.1L and 1.3L	31.500-31.515 mm (1.2402-1.2407 in)
Combustion Chamber Volume 1.1L	27.24-29.24 cc (4.22-4.53 cu in)
1.3L	31.79-33.79 cc (4.93-5.24 cu in)
Reface cylinder head mating surface: The following minimum combustion chamber depth must be left after skimming — 1.1L and 1.3L	14.4 mm ± 0.15 mm (0.567 in ± 0.006 in)

All specifications are in millimeters (inches).

For Conversion Factors see page 8.

^{b/} Ring Gap may exceed these specifications by 0.15 mm (0.006 in) when measurement is made in the block.

^{c/} Insert must be chilled in liquid nitrogen or dry ice prior to assembly.

SPECIFICATIONS (Continued)

ENGINE MODEL YEARS 1993+

Valve Mechanism	
Lash Intake — Cold	0.22 mm (0.009 in)
Exhaust — Cold	0.32 mm (0.013 in)
Stem Diameter Intake	7.025-7.043 mm (0.2766-0.2772 in)
Exhaust	6.999-7.017 mm (0.2756-0.2762 in)
Stem to Guide Clearance Intake	0.021-0.069 mm (0.0008-0.0027 in)
Exhaust 1.1L	0.046-0.095 mm (0.0018-0.0037 in)
1.3L	0.043-0.091 mm (0.0017-0.0036 in)
Length Intake	103.70-104.40 mm (4.083-4.110 in)
Exhaust	104.02-104.72 mm (4.096-4.122 in)
Head Diameter 1.1L Intake	32.90-33.10 mm (1.296-1.303 in)
Exhaust	28.90-29.10 mm (1.138-1.145 in)
Head Diameter 1.3L Intake	34.40-34.60 mm (1.355-1.362 in)
Exhaust	28.90-29.10 mm (1.138-1.145 in)
Seat Angle 1.1L and 1.3L	44.0°-44.5°
Spring Free Length 1.1L and 1.3L, Intake/Exhaust	41.0 mm (1.61 in)
Spring Assembled Height (Pad to Retainer)	33.22 mm (1.308 in)
Spring Load at Assembled Height	270 newtons (60.7 lb)
Tappet Diameter	13.081-13.094 mm (0.5150-0.5155 in)
Block Bore	13.110-13.143 mm (0.5162-0.5174 in)
Clearance to Block	0.016-0.062 mm (0.007-0.0024 in)
Rocker Shaft — Diameter	15.82-15.85 mm (0.6229-0.6240 in)
Rocker Bore	15.875-15.913 mm (0.6250-0.6264 in)
Shaft Clearance in Rocker	0.02-0.09 mm (0.0008-0.0035 in)
Lubrication	
Oil Type	Motorcraft Super Engine Oil, API SG
Oil Capacity With Filter (FL 400)	3.25 Liters (3.5 qts)
Without Filter	2.75 Liters (2.9 qts)
Oil Pressure — Hot at 2000 rpm (minimum)	1.5 Bars (22 psi)
Relief Valve Opens	2.41-2.75 Bars (35-40 psi)
Oil Pump Outer Rotor to Housing Clearance	0.14-0.26 mm (0.006-0.010 in)
Inner to Outer Rotor Gap	0.051-0.127 mm (0.002-0.005 in)
End Play — Rotors to Pump Cover	0.025-0.06 mm (0.0010-0.0023 in)

All specifications are in millimeters (inches).
For Conversion Factors see page 8.

SPECIFICATIONS (Continued)

ENGINE MODEL YEARS 1993+

Ignition System	
Firing Order	1-2-4-3
DIS ^{d/} (with 87 Octane Unleaded Gasoline) 1.1L and 1.3L	Fixed
Spark Plugs — AGRF 22 C1 (Gap)	1.0 mm (0.040 in)
Distributorless Type	
Coil Type	High Output DIS Coil
Coil Output	37.0 KV Minimum
Primary Resistance (at the Coil Tower)	0.50-1.00 Ohm
High Tension Leads	30,000 Ohms Max. per Lead
Belt Tension	
Alternator New	351-449 N (79-101 lbs)
Used-Reset (Minimum)	249-334 N (56-75 lbs)
Governor New	334 N (75 lbs)
Used-Reset (Minimum)	222 N (50 lbs)
Fuel System	
1.1L and 1.3L Unleaded 1986-	87 Octane
Pump Delivery Pressure	0.24-0.38 Bar (3.5-5.5 psi)
Starter — Current Draw	
Normal Engine Cranking	175 amps
Maximum Load — at Stall	410 amps
No Load	35 to 55 amps

All specifications are in millimeters (inches).

For Conversion Factors see page 8.

^{d/} Distributorless Ignition System.

SPECIFICATIONS (Continued)

SPECIAL SERVICE TOOLS

Description	Tool Number
Installer – Valve Stem Seal – Intake	21-007
Installer – Crankshaft Seal – Front Timing Cover	21-046
Installer – Rear Crankshaft Seal	21-059A
Remover – Crankshaft Oil Seals	21-096
Valve Spring Compressor	T81P-6513-A

Call Owatonna Tool Company

1-800-533-5338

Ask for Ford Order Desk

CONVERSION FACTORS

Pounds per Square Inch	Bars x 14.5
Cubic Inches	Cubic Centimeter x 0.061
Newton•Meter (Torque)	Ft-lbs x 1.3558
Millimeter	Inches x 25.4
Pounds	Kilogram (Force) x 2.2046
Cubic Inches	Liter x 61.024
Quarts	Liter x 1.0567
Inches	Millimeter x 0.03937
Pounds	Newton x 0.2248
Ft-lbs (Torque)	Newton•Meter x 0.7376

TORQUE SPECIFICATIONS

Item	Nm	Ft-Lb
Main Bearing Cap	88-102	64-75
Connecting Rod Bolts	1	
Rear Oil Seal Carrier	16 to 20	12-15
Flywheel	64 to 70	47-52
Clutch Pressure Plate	24 to 35	17.6-25.7
Chain Tensioner	24 to 25	17-18
Camshaft Thrust Plate	7 to 9	5-7
Camshaft Sprocket	16 to 20	12-15

TORQUE SPECIFICATIONS (Continued)

Item	Nm	Ft-Lb
Timing Cover	7 to 10	5-7.5
Water Pump	7 to 10	5-7.5
Crankshaft Pulley 1.1 and 1.3L 89/M.Y. and later	100 to 120	73.4-88
Water Pump Pulley	100-120	73.4-88
Starter Motor	35 to 45	26-33
Fuel Pump	16 to 20	12-15
Distributor Retaining Bolt	7 to 10	5-7.5
Distributor Clamp Bolt	3 to 4	2-2.5
Oil Pump	16 to 20	12-15
Oil Pump Cover	8 to 12	6-9
Oil Pump Pickup Tube Bracket	20 to 25	15-18
Oil Pan — Step 1 Alphabetical	6 to 8	5-6
— Step 2 Numerical	8 to 11	6-8
— Step 3 Alphabetical	8 to 11	6-8
Retorque after engine has warmed up (15 minutes at 1000 rpm)		
Oil Pan Plug	21 to 28	15-20
Oil Pressure Switch	13 to 15	10-11
Temperature Sender	4 to 8	3-6
Rocker Shaft Pedestals	40 to 46	30-34
Cylinder Head Bolts — Step 1	STEP 1-30	22
— Step 2	STEP 2-Turn	90° More
— Step 3	STEP 3-Turn	90° More
Rocker Cover	4 to 5	3-4
Exhaust Manifold	21 to 25	15-18
Inlet Manifold	16 to 20	12-15
Carburetor	17 to 21	12.5-15
Thermostat Housing	17 to 21	12.5-15
Spark Plugs	15 to 20	11-15
EGR Valve Bolts	16 to 20	12-15
EGR Hose	34 to 47	25-35

¹ **Step One** Torque to 4 N•m (3 Ft-lbs), **Step Two** Turn 90° more.